

呼び径	S	d	L	H	質量(kg)	Cv値	操作機型式		ランク
15 A	Rc 1/2	17	59	129	1.5	7	AM1-030	AM2-030	0
20 A	Rc 3/4	23	66	132	1.6	19	AM1-030	AM2-030	0
25 A	Rc 1	28	78	137	1.8	28	AM1-030	AM2-030	0
32 A	Rc1 1/4	31	87	137	2	28	AM1-030	AM2-030	0
40 A	Rc1 1/2	43	95	149	2.5	86	AM1-070	AM2-070	0
50 A	Rc 2	48	109	149	3	86	AM1-070	AM2-070	0

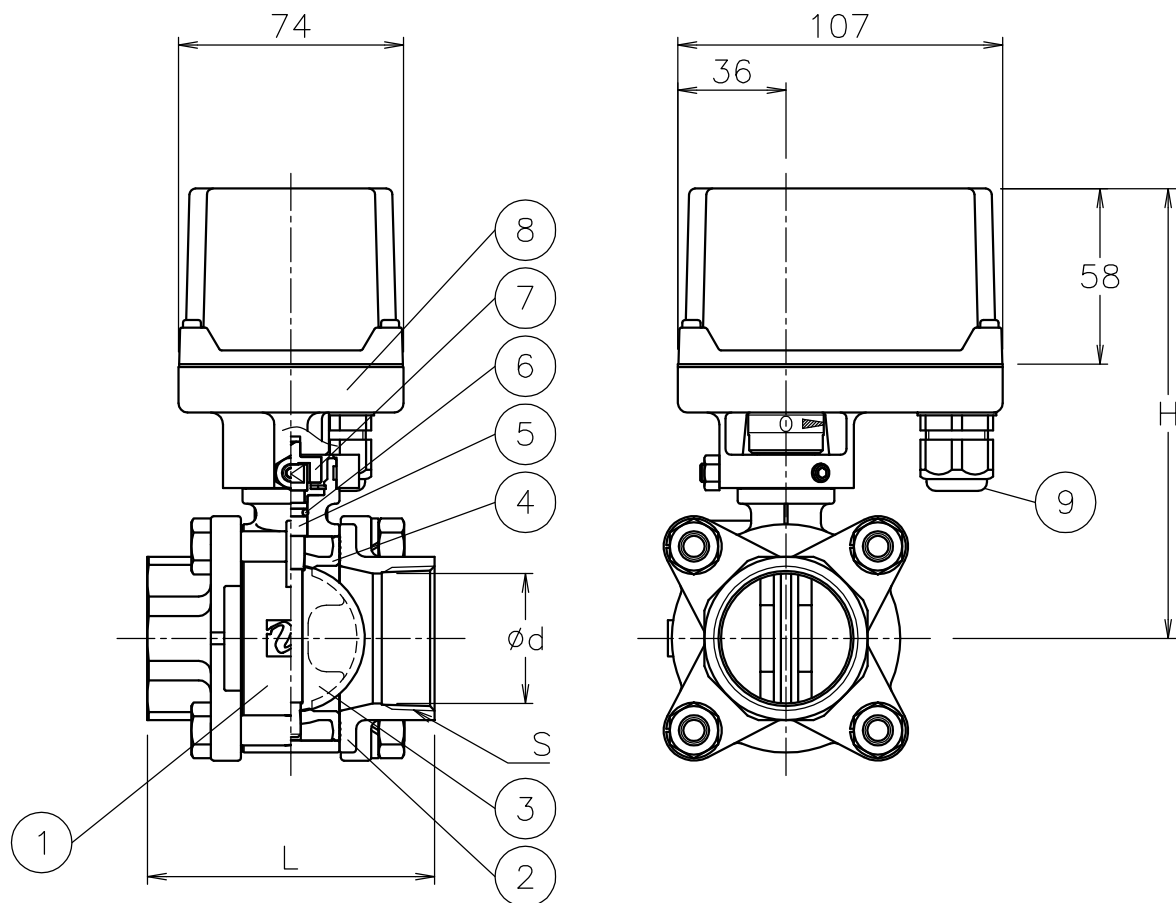

NOTE

(a) ケーブルグランドの適合ケーブル外径は $\phi 5 \sim 10.5$

9	ケーブルグランド	NYLON 6	1	G3/8 (a)
8	電動操作機	ADC12/PC CASE	1	
7	コネクタ	SUS304/PPS樹脂	1	
6	Oリング	EPDM	1	
5	ステム	SUS316	1	
4	シート	EPDM	1	
3	弁体	PPS樹脂	1	
2	キャップ	SCS14A	2	
1	本体	SCS13A	1	
No	DESCRIPTION	MATERIALS	REQ' D	REMARKS

			APPR' D	H. F	TITLE	Reねじ込み形 Z型モータバタフライバルブ					
			CHK' D	K. Y							
			DESIGN		MODEL	AM1Z-*05TUE AM2Z-*05TUE					
			DRAWN	S. O							
MARK	DATE	BY	DATE	'19-09-26	SCALE	NON	DWG No.	Z-05TUE-AM3			
	REVISIONS							 NIPPON VALVE CONTROLS, INC.			
	MV-2798										