

口径	d	L	D	C	n-h	H	質量(kg)	Cv値	操作機型式			ランク
40 A	40	40	80	95	4-15	331	7.2	85	AD1-300	AD2-300	ADO-300	0
50 A	50	40	90	105	4-15	336	7.3	145	AD1-300	AD2-300	ADO-300	0
65 A	65	40	115	130	4-15	348	7.7	290	AD1-300	AD2-300	ADO-300	0
80 A	80	50	126	145	4-19	380	8.6	450	AD1-300	AD2-300	ADO-300	0
100 A	105	50	146	165	8-19	391	8.8	780	AD1-300	AD2-300	ADO-300	0
125 A	130	50	181	200	8-19	408	9.6	1200	AD1-300	AD2-300	ADO-300	0
150 A	154	50	211	230	8-19	423	11	1800	AD1-300	AD2-300	ADO-300	0
200 A	204	50	257	280	8-23	446	13	3200	AD1-300	AD2-300	ADO-300	0
							13		AD1-700	AD2-700	ADO-700	2
250 A	253	50	322	345	12-23	468	17	5100	AD1-300	AD2-300	ADO-300	0
							17		AD1-700	AD2-700	ADO-700	2
300 A	300	55	367	390	12-23	494	19	7200	AD1-300	AD2-300	ADO-300	0
							19		AD1-700	AD2-700	ADO-700	2
350 A	340	70	410	435	12-25	545	29	8900	AD1-700	AD2-700	ADO-700	0
400 A	387	70	470	495	16-25	569	34	11000	AD1-700	AD2-700	ADO-700	0

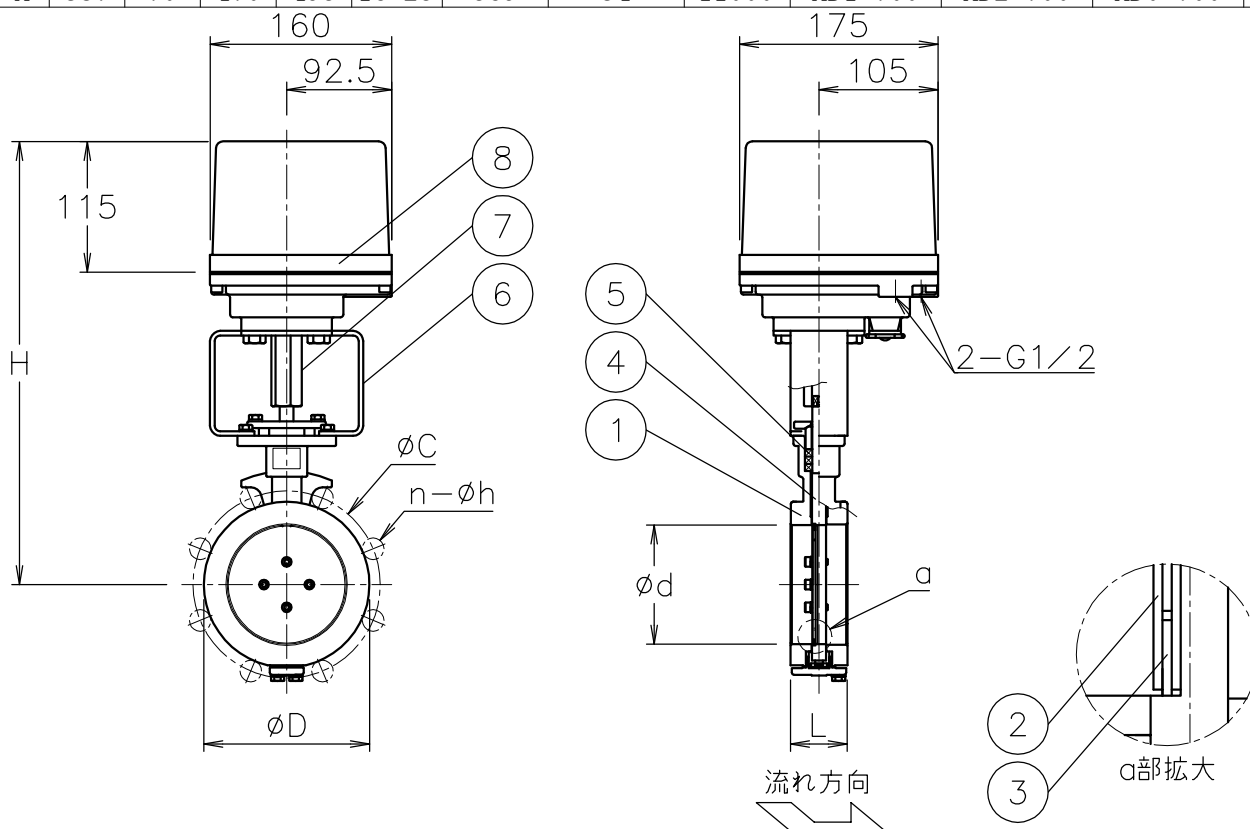

NOTE

付属品

- ・ケーブルコネクタ(ナイロン製), G1/2, 適合ケーブルφ6~12
- ・プラグ

8	電動操作機	アルミダイカストケース	1	
7	コネクタ	SCS13A	1	
6	ブラケット	SUS304	1	
5	グランドパッキン	膨張黒鉛	1	
4	ステム	SUS420J2	1	
3	シールリング	SUS316	1	
2	弁体	SUS410S SUS420J2	1	
1	本体	SCS13A	1	
No	DESCRIPTION	MATERIALS	REQ'D	REMARKS

			APPR'D	H. F	TITLE	J 5 K ウエハー式 口径: 40~400 A WT 型モータバタフライダンパ					
			CHK'D	K. Y		MODEL	AD1WT**2TGS AD2WT**2TGS ADOWT0*2TGS				
			DESIGN		SCALE		NON	DWG No.	WT-*2TGS-AD3		
MARK	DATE	BY	DATE	'16-09-15							
REVISIONS				 NIPPON VALVE CONTROLS, INC.							
MV-2547											