

呼び径	d	L	d1	D1	ℓ	1/T テーパ	H1	W1	W2	W3	W4	W5	H	質量(kg)	Cv値 (P1/P2)	操作機型式		ランク
15 A	15	108	22.11	48	20	1/34	77	122	60	145	60	102	195	2.8	6.3	AE1-120	AE2-120	0
20 A	20	128	26.13	60	24	1/34	93	122	60	145	60	102	202	3	8.5	AE1-120	AE2-120	0
25 A	25	145	32.16	70	27	1/34	112	122	60	145	60	102	209	3.2	20	AE1-120	AE2-120	0
32 A	40	174	38.19	100	30	1/34	147	122	60	145	60	102	226	4	27	AE1-120	AE2-120	0
40 A	40	189	48.21	100	37	1/37	154	122	60	145	60	102	226	4	36	AE1-120	AE2-120	0
50 A	51	220	60.25	126	42	1/37	180	122	60	145	60	102	238	5.8	45	AE1-300	AE2-300	0
65 A	78	316	76.6	152	61	1/48	261	122	60	145	60	102	283	8.9	84	AE1-600	AE2-600	0
80 A	78	316	89.6	152	64	1/49	261	122	60	145	60	102	283	8.9	99	AE1-600	AE2-600	0
100 A	100	418	114.7	210	84	1/56	328	122	60	145	60	102	324	17	200	AE1-600	AE2-600	0
								160	97	175	63	115	373	23		AE1-02K	AE2-02K	2

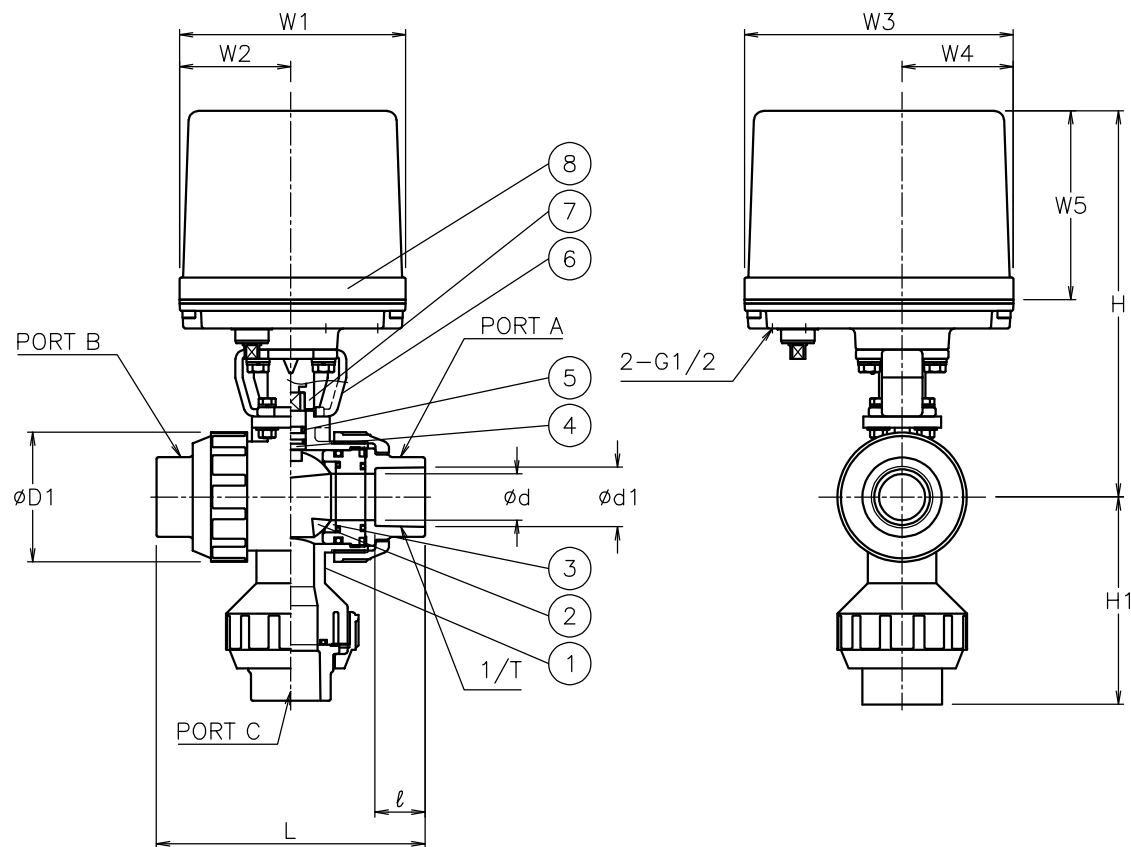

NOTE
 付属品
 ・ケーブルグランド* (ナイロン製), G1/2, 適合ケーブルφ6~12
 ・プラグ

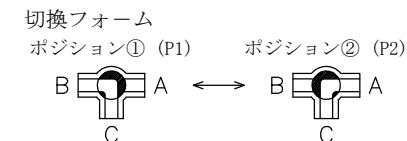

8	電動操作機	アルミダイカストケース	1	
7	コネクタ	SCS13A/SUS304	1	
6	ブラケット	SCS13A/SUS304	1	
5	Oリング	EPDM	2	
4	ステム	PVC	1	
3	シート	PTFE	2	
2	ボール	PVC	1	
1	本体	PVC	1	
No	DESCRIPTION	MATERIALS	REQ'D	REMARKS

			APPR'D	H. F	TITLE	ソケット形 PL型モータボールバルブ								
			CHK'D	K. Y		MODEL	AE1PL**7PPE AE2PL**7PPE							
			DESIGN				MARK	DATE	BY	DATE	SCALE	NON	DWG No.	PL-*7PPE-AE3
			DRAWN	S. O										
REVISIONS														
MV-2882														

NIPPON VALVE CONTROLS, INC.