

呼び径	d	d2	d1	L	D	ℓ	H1	X	M	S1	h1	h2	H	質量 [kg]	Cv値	操作機型式		ランク
15 A	15	20.2	21.2	108	48	20	29	19	7.3	11	36	58	143	1.3	14	AM1-030	AM2-030	0
20 A	20	25.2	26.2	126	60	23	35	19	7.3	11	36	58	149	1.4	29	AM1-070	AM2-070	0
25 A	25	32	33	141	70	25	39	19	7.3	11	36	58	156	1.5	47	AM1-070	AM2-070	0
40 A	40	46	47	171	100	28	55	30	9	15	53	85	235	2.5	155	AM1-180	AM2-180	0

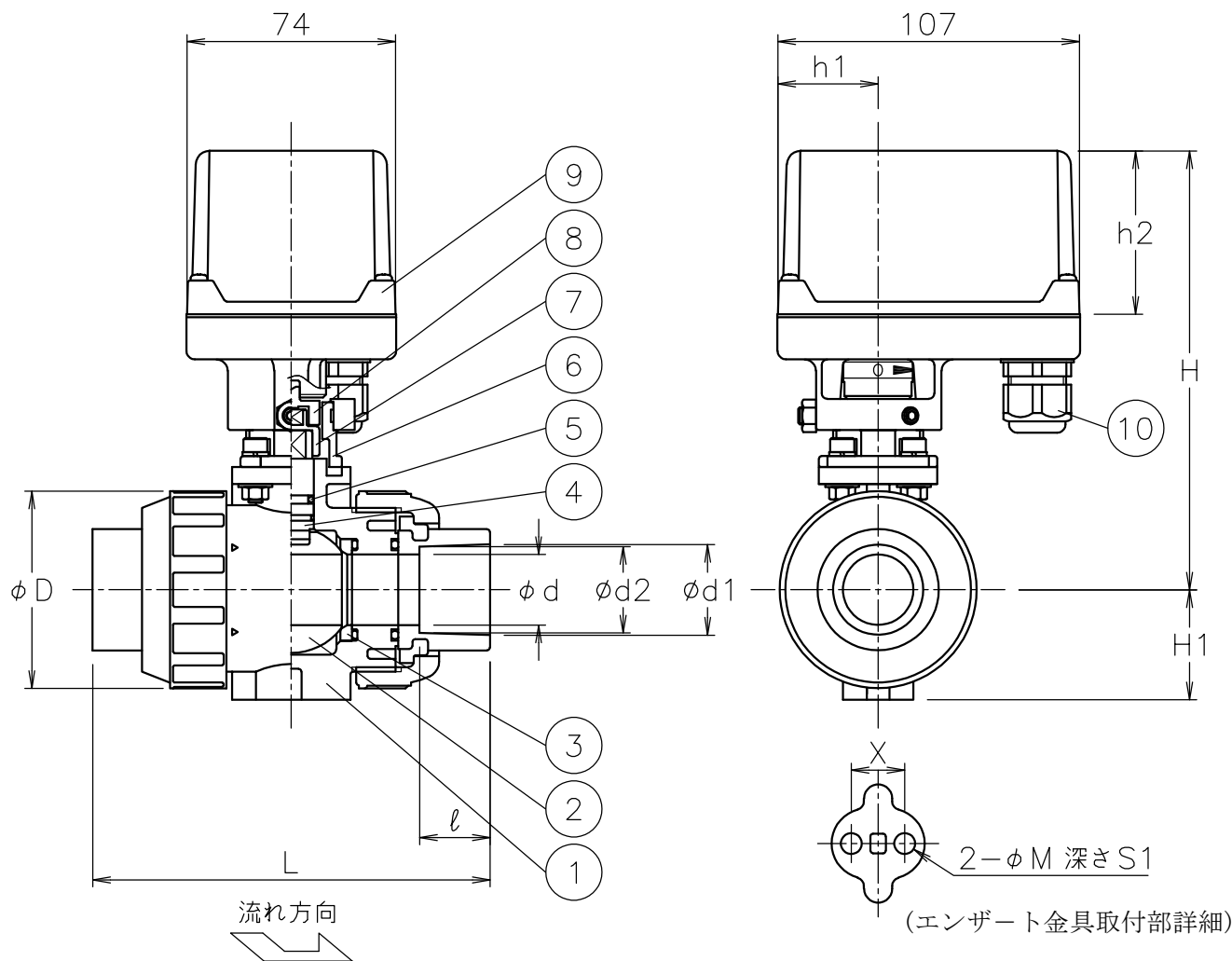

NOTE

(a) 適合ケーブル外径 φ5~10.5

10	ケーブルグラブ	NYLON 6	1	G 3/8 (a)
9	電動操作機	ADC12/PC CASE	1	
8	コネクタ	SUS304	1	
7	コネクタ	SCS13A	1	
6	ブラケット	SCS13A	1	
5	Oリング	FKM	2	
4	ステム	PP	1	
3	シート	PTFE	2	
2	ボール	PP	1	
1	本体	PP	1	
No	DESCRIPTION	MATERIALS	REQ'D	REMARKS

			APPR'D	H. F	TITLE	ソケット形 PA型モータボールバルブ			
			CHK'D	K. Y					
			DESIGN		MODEL	AM1PA*07QQV AM2PA*07QQV			
			DRAWN	S. O					
MARK	DATE	BY	DATE	'20-04-21	SCALE	NON	DWG No.	PA-07QQV-AM4	
REVISIONS			 <b>NIPPON VALVE CONTROLS, INC.</b>						
MV-2829									