

呼び径	d	D1	d1	ℓ	1/Tターハ	L	H1	X	M	S1	W1	W2	W3	W4	W5	H	質量[kg]	Cv値	操作機型式		ランク
15 A	15	48	22.11	20	1/34	109	29	19	7.3	11	122	60	145	60	102	195	2.8	14	AE1-120	AE2-120	0
20 A	20	60	26.13	24	1/34	128	35	19	7.3	11	122	60	145	60	102	202	2.9	29	AE1-120	AE2-120	0
25 A	25	70	32.16	27	1/34	145	39	19	7.3	11	122	60	145	60	102	209	3.1	47	AE1-120	AE2-120	0
32 A	32	82	38.19	30	1/34	162	47	30	9	15	122	60	145	60	102	218	3.2	72	AE1-120	AE2-120	0
40 A	40	100	48.21	37	1/37	189	55	30	9	15	122	60	145	60	102	226	3.6	155	AE1-120	AE2-120	0
50 A	51	126	60.25	42	1/37	220	66	30	9	15	122	60	145	60	102	238	5	190	AE1-300	AE2-300	0
65 A	65	133	76.6	61	1/48	273	72	48	9	6	122	60	145	60	102	258	6	365	AE1-300	AE2-300	0
																			AE1-600	AE2-600	2
80 A	78	152	89.6	64	1/49	316	85	55	11	7	122	60	145	60	102	283	7.5	410	AE1-600	AE2-600	0
100 A	100	210	114.7	84	1/56	419	110	65	11	8	122	60	145	60	102	324	14	680	AE1-600	AE2-600	0
											160	97	175	63	115	373	20		AE1-02K	AE2-02K	2

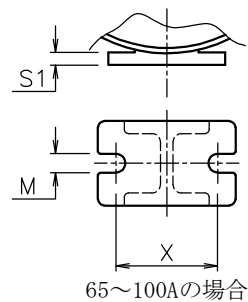
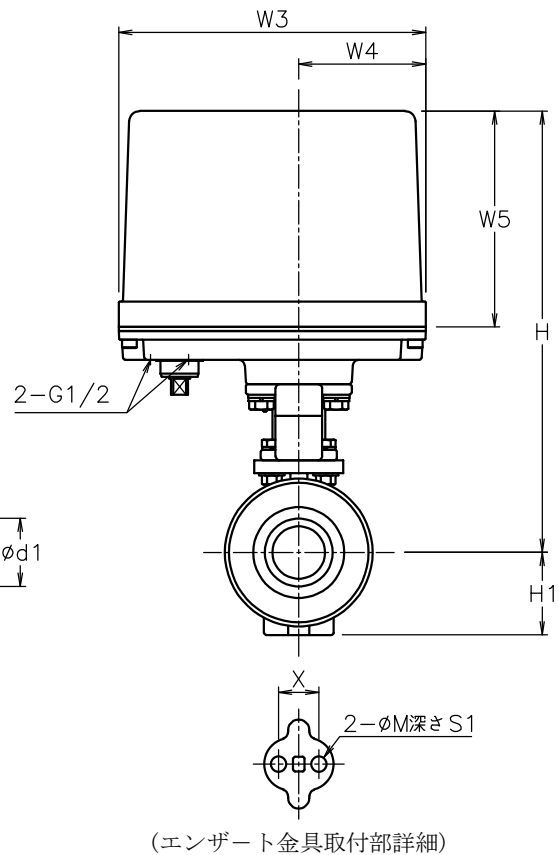
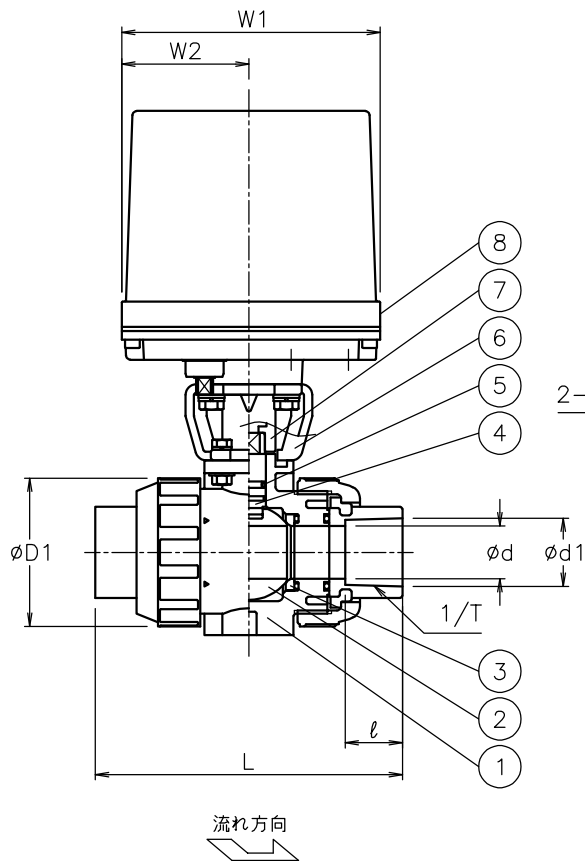

NOTE  
 付属品  
 ・ケーブルラッド (ナイロン製), G1/2, 適合ケーブルφ6~12  
 ・プラグ

※ 65~100Aでは、  
 流れ方向の指定はありません

8	電動操作機	アルミダイカストケース	1	
7	コネクタ	SCS13A/SUS303	1	
6	ブラケット	SCS13A/SUS304	1	
5	Oリング	FKM	2	
4	ステム	C-PVC	1	高温用PVC
3	シート	PTFE	2	
2	ボール	C-PVC	1	高温用PVC
1	本体	C-PVC	1	高温用PVC
No	DESCRIPTION	MATERIALS	REQ'D	REMARKS

			APPR'D	H. F	TITLE	ソケット形 PA型モータボールバルブ						
			CHK'D	K. Y		MODEL	AE1PA**7HHV AE2PA**7HHV					
			DESIGN				SCALE	NON	DWG No.	PA-*7HHV-AE4		
MARK	DATE	BY	DATE	21-03-30								
REVISIONS												
MV-2895												
					<b>NIPPON VALVE CONTROLS, INC.</b>							