

呼び径	d	D1	d1	ℓ	1/Tテーパ°	L	H1	X	M	S1	h1	h2	H	質量[kg]	Cv値	操作機型式	ランク
15 A	15	48	22.11	20	1/34	109	29	19	7.3	11	36	58	143	1.3	14	AM*-030	0
20 A	20	60	26.13	24	1/34	128	35	19	7.3	11	36	58	149	1.4	29	AM*-070	0
25 A	25	70	32.16	27	1/34	145	39	19	7.3	11	36	58	156	1.6	47	AM*-070	0
32 A	32	82	38.19	30	1/34	162	47	30	9	15	36	58	173	1.9	72	AM*-070	0
40 A	40	100	48.21	37	1/37	189	55	30	9	15	53	85	234	2.7	155	AM*-180	0

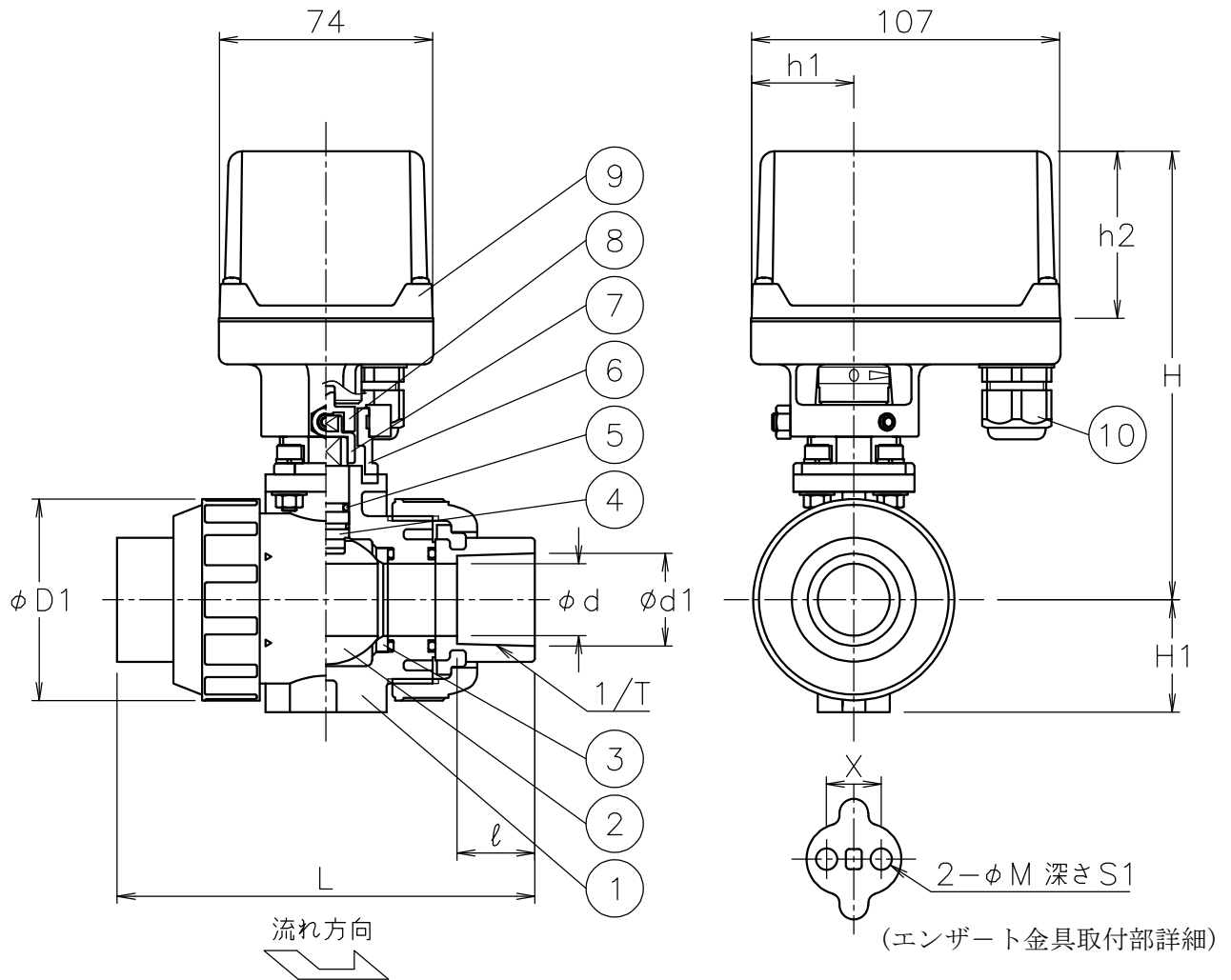

NOTE

(a) 適合ケーブル外径 φ5~10.5

10	ケーブルグランド	NYLON 6	1	G 3/8 (a)
9	電動操作機	ADC12/PC CASE	1	
8	コネクタ	SUS304	1	
7	コネクタ	SCS13A	1	
6	ブラケット	SCS13A	1	
5	Oリング	EPDM	2	
4	ステム	C-PVC	1	高温用PVC
3	シート	PTFE	2	
2	ボール	C-PVC	1	高温用PVC
1	本体	C-PVC	1	高温用PVC
No	DESCRIPTION	MATERIALS	REQ'D	REMARKS

			APPR'D	H. F	TITLE	ソケット形 PA型モータボールバルブ			
			CHK'D	K. Y		MODEL	AM1PA*07HHE AM2PA*07HHE		
			DESIGN		SCALE		NON	DWG No.	PA-07HHE-AM5
			DRAWN	S. O					
MARK	DATE	BY	DATE	'21-12-17					
REVISIONS			 NIPPON VALVE CONTROLS, INC.						
MV-2945									