

呼び径	S	d	L	D1	ℓ	P	X	M	S1	W	N	N1	H1	H	質量 (kg)	Cv値	操作機型式	ランク
15 A	Rc 1/2	15	100	48	15	1/8	19	7.3	11	110	57	32	29	153	1.3	14	TAD-040	0
20 A	Rc 3/4	20	119	60	17	1/8	19	7.3	11	110	57	32	35	160	1.5	29	TAD-040	0
25 A	Rc 1	25	130	70	20	1/8	19	7.3	11	110	57	32	39	167	1.6	47	TAD-040	0
32 A	Rc1 1/4	32	146	82	22	1/8	30	9	15	110	57	32	47	184	2	72	TAD-040	0
40 A	Rc1 1/2	40	160	100	25	1/4	30	9	15	170	82	36	55	220	2.9	155	TAD-050	0
50 A	Rc 2	51	194	126	28	1/4	30	9	15	170	82	36	66	232	3.8	190	TAD-050	0
										204	95	38		247	4.6			
65 A	Rc2 1/2	65	212	133	32	1/4	48	9	6	204	95	38	72	267	5.3	365	TAD-063	0
80 A	Rc 3	78	261	152	35	1/4	55	11	7	204	95	38	85	276	7	410	TAD-063	0
										240	116	45		318	8.7			
100 A	Rc 4	100	357	210	45	1/4	65	11	8	240	116	45	110	350	16	680	TAD-080	0

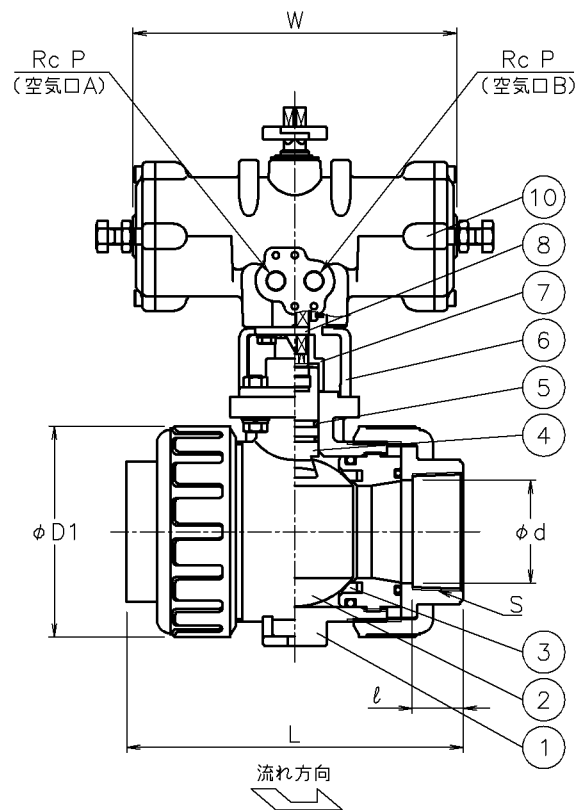

※ 65~100Aでは、流れ方向の指定はありません

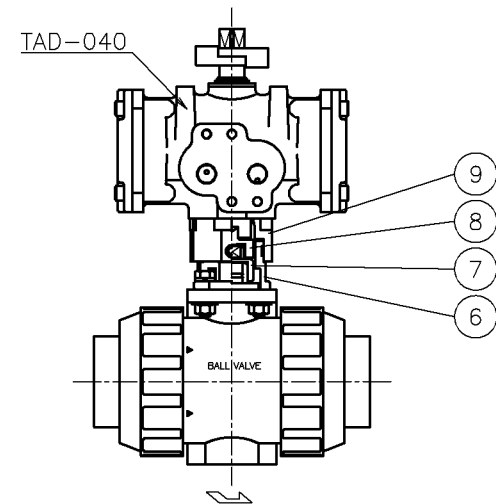
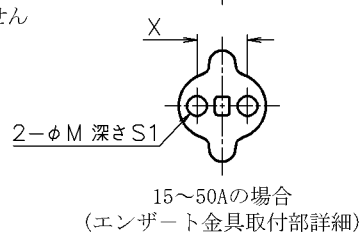
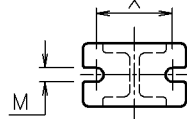
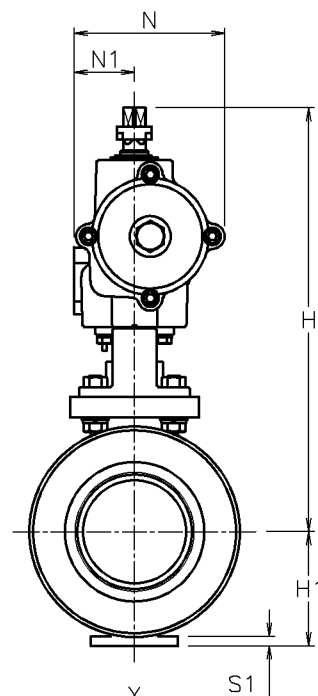

TADPA905RRV-015
TADPA905RRV-020
TADPA905RRV-025
TADPA905RRV-032

NOTE

- ① 標準操作圧力 : 0.4~0.5MPa 最大0.7MPa
- ② 操作機動作
 - ・空気口Aへ空気導入によりバルブ閉
 - ・空気口Bへ空気導入によりバルブ開

No	DESCRIPTION	MATERIALS	REQ'D	REMARKS
10	エア作動操作機		1	TAD
9	延長ブラケット	BERIC	1	
8	コネクタ	SUS304	1	
7	コネクタ	SUS303/SCS13A	1	
6	ブラケット	SUS304/SCS13A	1	
5	Oリング	FKM	2	
4	ステム	PVDF	1	
3	シート	PTFE	2	
2	ボール	PVDF	1	
1	本体	PVDF	1	

MARK	DATE	BY	DATE	SCALE	NON	DWG No.	PA-9*5RRV-TA1
REVISIONS				MV-2557			
APPR'D				H. F			
CHR'D				K. Y			
DESIGN				TITLE			
DRAWN				P. O			
MODEL				TADPA9*5RRV			
SCALE				NON			
DWG No.				PA-9*5RRV-TA1			