

呼び径	S	d	L	D1	ℓ	P	X	M	S1	W	N	N1	H1	H	質量 (kg)	Cv値	操作機型式	ランク
15 A	Rc 1/2	15	102	48	15	1/8	19	7.3	11	110	57	32	29	153	1.3	14	TAD-040	0
20 A	Rc 3/4	20	120	60	17	1/8	19	7.3	11	110	57	32	35	160	1.4	29	TAD-040	0
25 A	Rc 1	25	131	70	20	1/8	19	7.3	11	110	57	32	39	167	1.5	47	TAD-040	0
32 A	Rc1 1/4	32	150	82	22	1/8	30	9	15	110	57	32	47	184	1.9	72	TAD-040	0
40 A	Rc1 1/2	40	163	100	25	1/4	30	9	15	170	82	36	55	220	2.7	155	TAD-050	0
50 A	Rc 2	51	197	126	28	1/4	30	9	15	170	82	36	66	232	3.4	190	TAD-050	0
										204	95	38		247	4.2		TAD-063	2
65 A	Rc2 1/2	65	215	133	32	1/4	48	9	6	204	95	38	72	267	4.8	365	TAD-063	0
80 A	Rc 3	78	265	152	35	1/4	55	11	7	204	95	38	85	276	6.2	410	TAD-063	0
										240	116	45		318	7.9		TAD-080	2
100 A	Rc 4	100	362	210	45	1/4	65	11	8	240	116	45	110	350	13	680	TAD-080	0

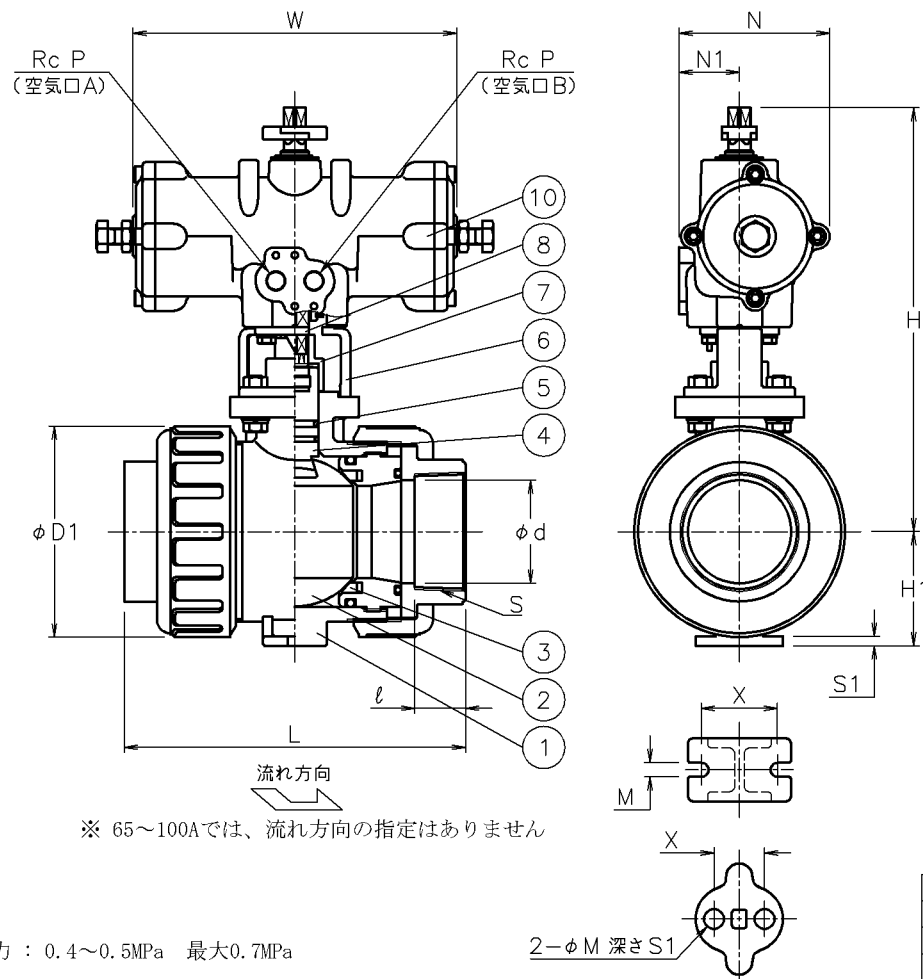

NOTE  
 ① 標準操作圧力 : 0.4~0.5MPa 最大0.7MPa  
 ② 操作機動作  
 ・空気口Aへ空気導入によりバルブ閉  
 ・空気口Bへ空気導入によりバルブ開

15~50Aの場合  
 (エンザート金具取付部詳細)

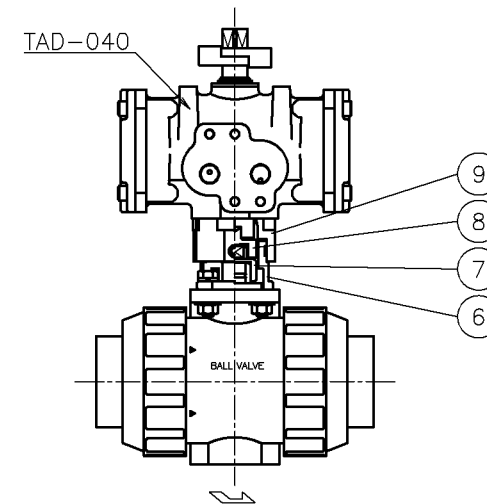

TADPA905PPE-015  
 TADPA905PPE-020  
 TADPA905PPE-025  
 TADPA905PPE-032

No	DESCRIPTION	MATERIALS	REQ'D	REMARKS
10	エア作動操作機		1	TAD
9	延長ブラケット	BERIC	1	
8	コネクタ	SUS304	1	
7	コネクタ	SUS303/SCS13A	1	
6	ブラケット	SUS304/SCS13A	1	
5	Oリング	EPDM	2	
4	ステム	PVC	1	
3	シート	PTFE	2	
2	ボール	PVC	1	
1	本体	PVC	1	

APPR'D	H. F	TITLE	Rcねじ込み式 (複作動形) PA型エア作動ボールバルブ		
CHR'D	K. Y	MODEL	TADPA9*5PPE		
DESIGN		SCALE	NON	DWG No.	PA-9*5PPE-TA2
DRAWN	P. O	MARK	DATE	BY	DATE
REVISIONS		16-11-17			
MV-2557		<b>Upro NIPPON VALVE CONTROLS, INC.</b>			