

呼び径	d	L	D	C	n-h	W1	W2	φK	H2	質量 (kg)	Cv値 ON/OFF	操作機型式
65 A	65	240	175	140	4-19	157	45	150	150	23	240	MAG-F07
80 A	76	260	185	150	8-19	157	45	150	158	27	380	MAG-F07
100 A	100	330	210	175	8-19	240	63	300	184	44	680	MAG-F10
125 A	122	370	250	210	8-23	240	63	300	202	59	1080	MAG-F10
150 A	145	430	280	240	8-23	226	78	300	224	85	1620	MAG-F12

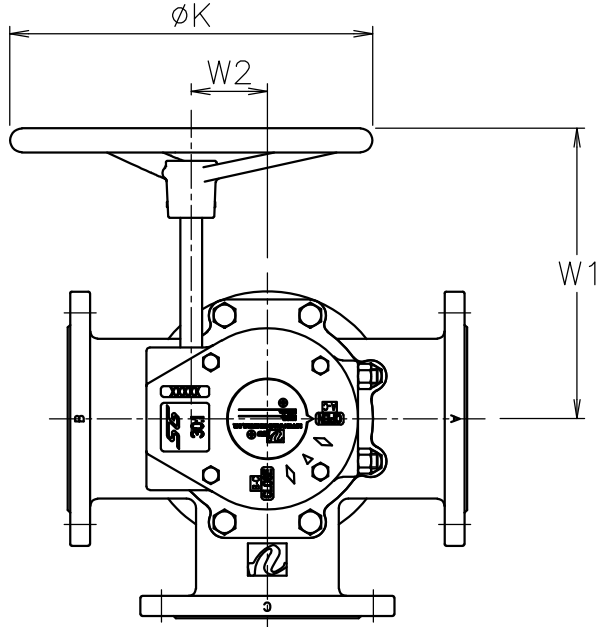

型式	減速比
MAG-F07	24:1
MAG-F10	30:1
MAG-F12	50:1

切換フォーム (ギア側から見る)

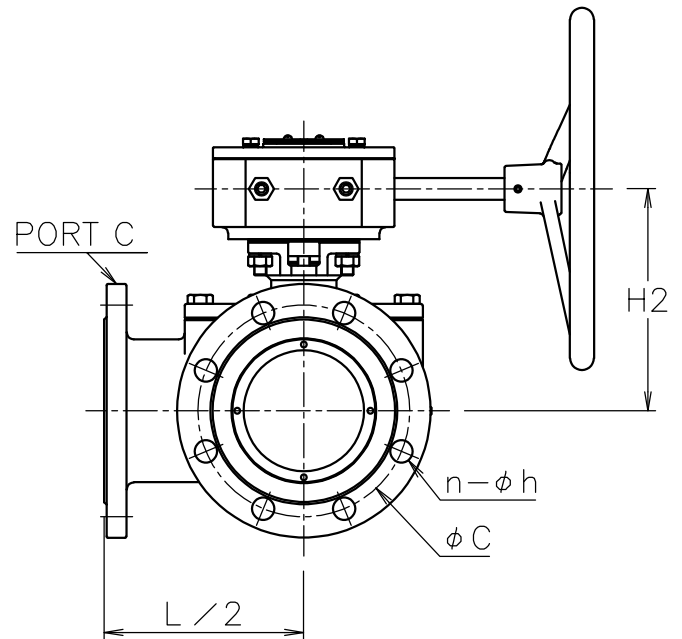
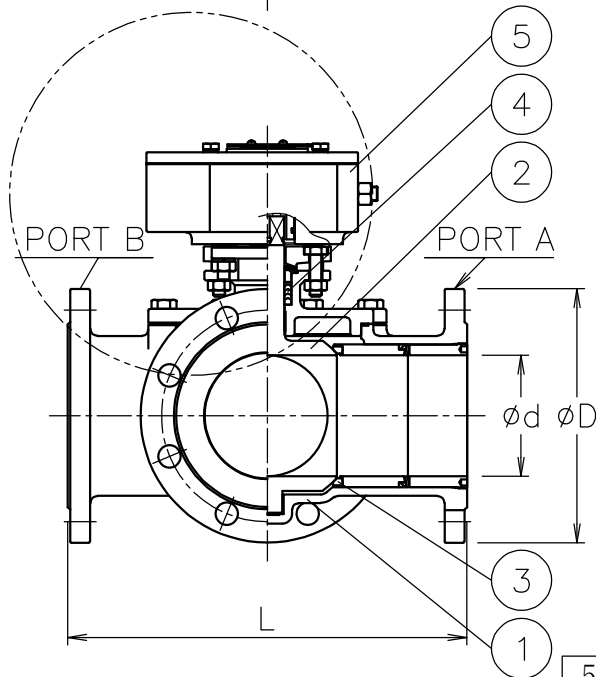
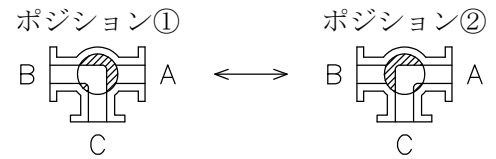

NOTE

(a) ギアのハンドルは取り外した状態で出荷
MAG-F07, MAG-F10 : FC250
MAG-F12 : FC200

5	ギア	FC200/FC250 (ケース)	1	(a)
4	パッキン	PTFE	1set	
3	シート	強化PTFE	2	
2	ボール・ステム	SCS13A	1	
1	本体	SCS13A	1	
No	DESCRIPTION	MATERIALS	REQ'D	REMARKS

			APPR'D	H. F	TITLE	J10Kフランジ式 L3型手動ボールバルブ					
			CHK'D	K. Y							
			DESIGN		MODEL	MAXL3G-1TTG					
			DRAWN	P. O							
MARK	DATE	BY	DATE	'20-12-25	SCALE	NON	DWG No.	L3-1TTG-G-MA3			
REVISIONS			 NIPPON VALVE CONTROLS, INC.								
MV-2876											