

呼び径	d	L	D	C	n-h	W1	W2	W3	W4	W5	H	質量 (kg)	Cv値		操作機型式	ランク
													実効	P1/P2		
25 A	25	160	125	90	4-19	122	60	145	60	102	230	8.2	20	40	AEX-120	0
												8.6			AEX-360	2
40 A	40	180	140	105	4-19	122	60	145	60	102	253	12	60	100	AEX-360	0
											269				AEX-700	2
50 A	50	200	155	120	4-19	122	60	145	60	102	260	15	110	170	AEX-360	0
											276				AEX-700	2
65 A	65	240	175	140	4-19	122	60	145	60	102	297	22	150	240	AEX-700	0
80 A	76	260	185	150	8-19	122	60	145	60	102	305	26	240	380	AEX-700	0
						160									97	175
100 A	100	330	210	175	8-19	160	97	175	63	115	387	43	440	680	AEX-02K	0
125 A	122	370	250	210	8-23	160	97	175	63	115	405	59	680	1080	AEX-02K	1
						195									75	220
150 A	145	430	280	240	8-23	195	75	220	75	130	490	87	1030	1620	AEX-06K	0

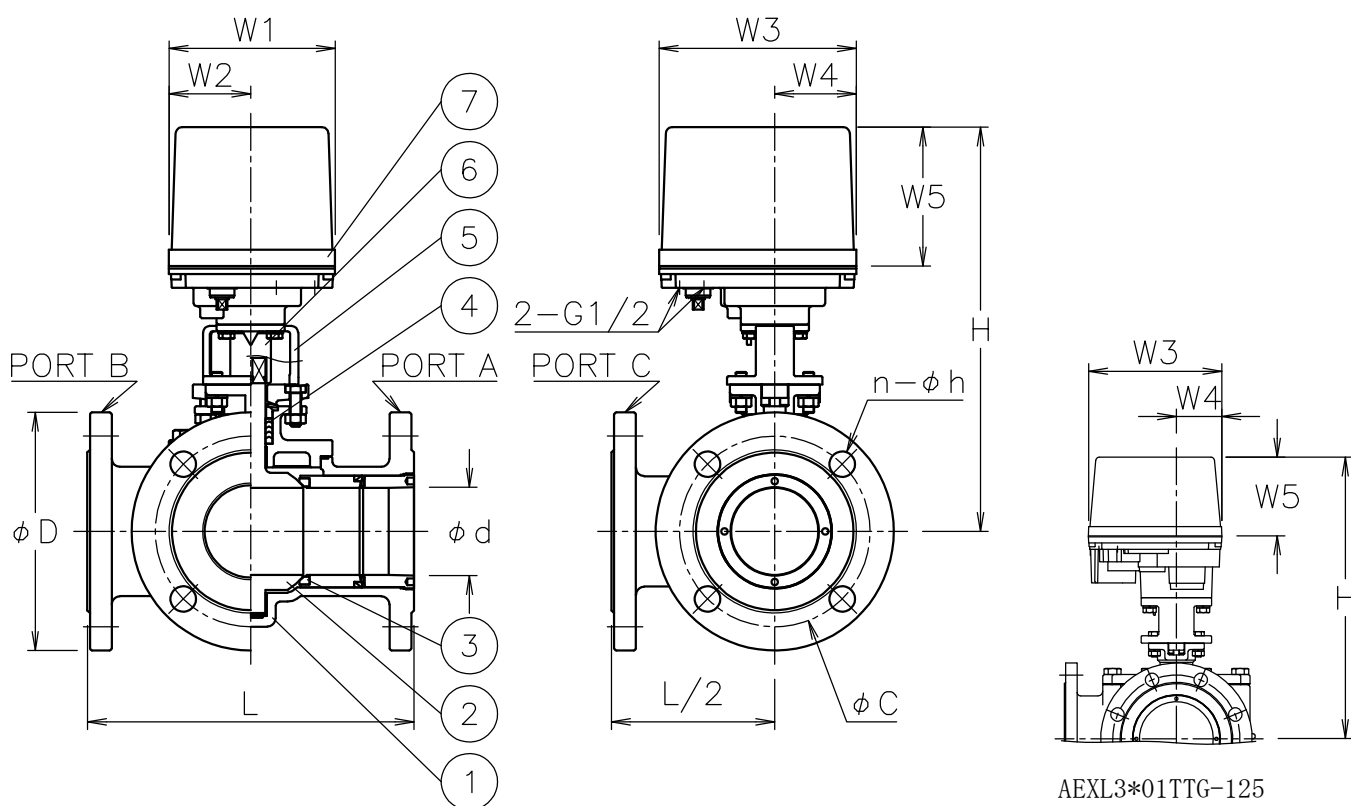

NOTE

付属品

- ・ケーブルグランド (ナイロン製), G1/2, 適合ケーブルφ6~12
- ・プラグ

切換フォーム (電動操作機側から見る)

ポジション①(P1) ポジション②(P2)

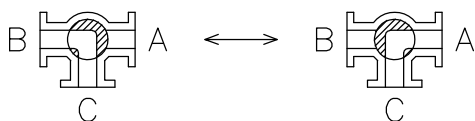

7	電動操作機	アルミダイカストケース	1	
6	コネクタ	SUS304	1	
5	ブラケット	SCS13A	1	
4	パッキン	PTFE	1	
3	シート	強化PTFE	2	
2	ボール・システム	SCS13A	1	
1	本体	SCS13A	1	
No	DESCRIPTION	MATERIALS	REQ'D	REMARKS

			APPR'D	H. F	TITLE	J10Kフランジ形 L3型コントロールバルブ								
			CHK'D	K. Y		MODEL	AEXL3**1TTG							
			DESIGN		MARK		DATE	BY	DATE	'20-09-08	SCALE	NON	DWG No.	L3-*1TTG-EX6
			DRAWN	S. O			REVISIONS							
					MV-									
					NIPPON VALVE CONTROLS, INC.									