

呼び径	d	L	D	C	n-h	H	質量 (kg)	Cv値 P1/P2	操作機型式		ランク
25 A	25	160	125	90	4-19	350	16	40	ABR-300	HBR-300	0
40 A	40	180	140	105	4-19	373	19	100	ABR-300	HBR-300	0
50 A	50	200	155	120	4-19	380	23	170	ABR-700	HBR-700	0
65 A	65	240	175	140	4-19	393	29	240	ABR-700	HBR-700	0
80 A	76	260	185	150	8-19	401	33	380	ABR-700	HBR-700	0
						423			—	HBR-02K	2
100 A	100	330	210	175	8-19	447	46	680	—	HBR-02K	0
125 A	122	370	250	210	8-23	465	62	1080	—	HBR-02K	1
						506			68	—	HBR-06K
150 A	145	430	280	240	8-23	531	90	1620	—	HBR-06K	0

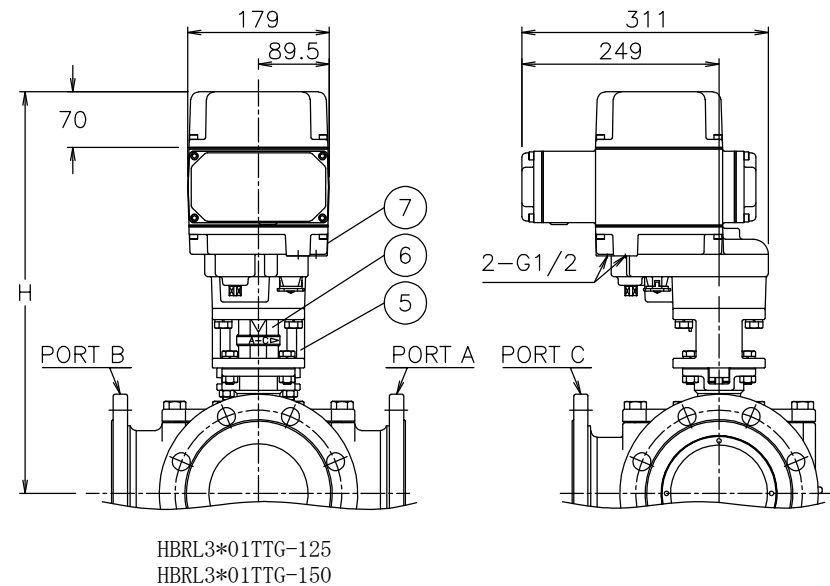

NOTE
付属品
・ケーブルラント[®](ナイロン製), G1/2, 適合ケーブルφ6~12
・プラグ

切換フォーム (操作機側から見る)
ポジション①(P1) ポジション②(P2)

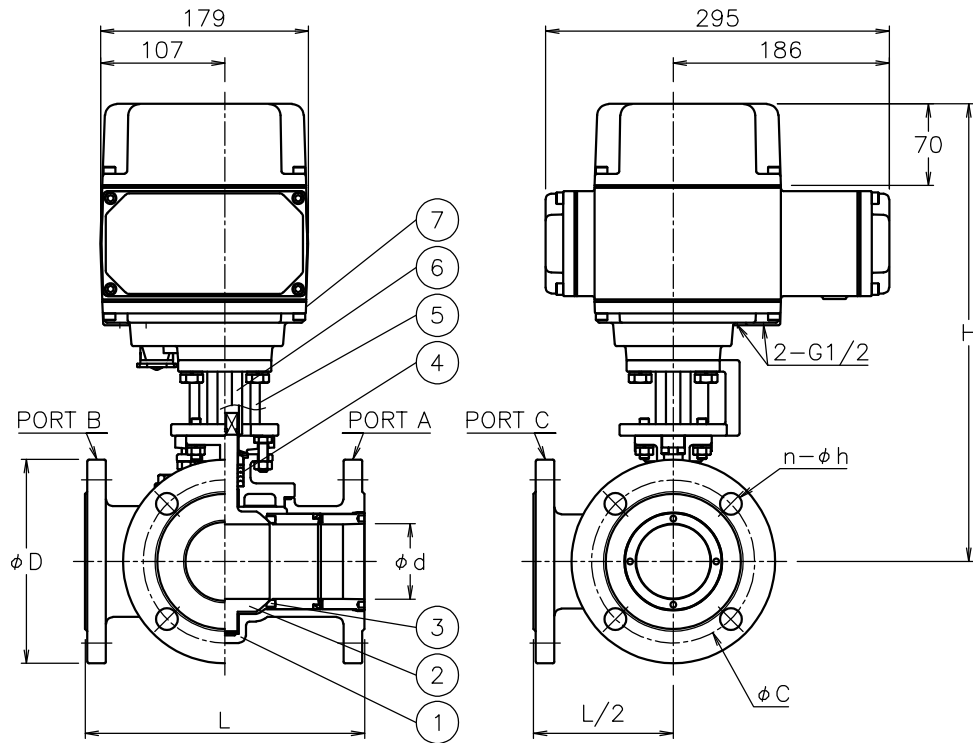
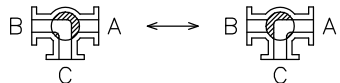

7	電動操作機	AC4C	1	
6	コネクタ	SCS13A	1	
5	ブラケット	SCS13A	1	
4	パッキン	PTFE	1	
3	シート	強化PTFE	2	
2	ボール・ステム	SCS13A	1	
1	本体	SCS13A	1	
No	DESCRIPTION	MATERIALS	REQ'D	REMARKS

			APPR'D	H. F	TITLE	J10Kフランジ形 L3型電動緊急遮断型ボールバルブ				
			CHK'D	K. Y						
			DESIGN							
			DRAWN	S. O	MODEL	ABRL3**1TTG HBRL3**1TTG				
MARK	DATE	BY	DATE	'21-04-27		SCALE	NON	DWG No.	L3-*1TTG-AB4	
REVISIONS										
MV-2900										



NIPON VALVE CONTROLS, INC.