

呼び径	d	L	L1	J10K		J20K		H	質量(kg)	Cv値	操作機型式			ランク
				C	n-h	C	n-h				PHX-300	PHR-300	PDX-300	
R40 A	32	80	37	105	4-19	105	4-19	315	8.5	95	PHX-300	PHR-300	PDX-300	0
R50 A	38	95	45	120	4-19	120	8-19	346	11	135	PHX-700	PHR-700	PDX-700	2
R65 A	50	110	50	140	4-19	140	8-19	354	13	195	PHX-700	PHR-700	PDX-700	0
R80 A	64	125	57	150	8-19	160	8-23	392	18	410	PHX-02K	PHR-02K	PDX-02K	2
R100 A	74	145	67	175	8-19	185	8-23	417	22	430	PHX-02K	PHR-02K	PDX-02K	2
R125 A	100	176	81	210	8-23	225	8-25	487	38	900	PHX-06K	PHR-06K	PDX-06K	2

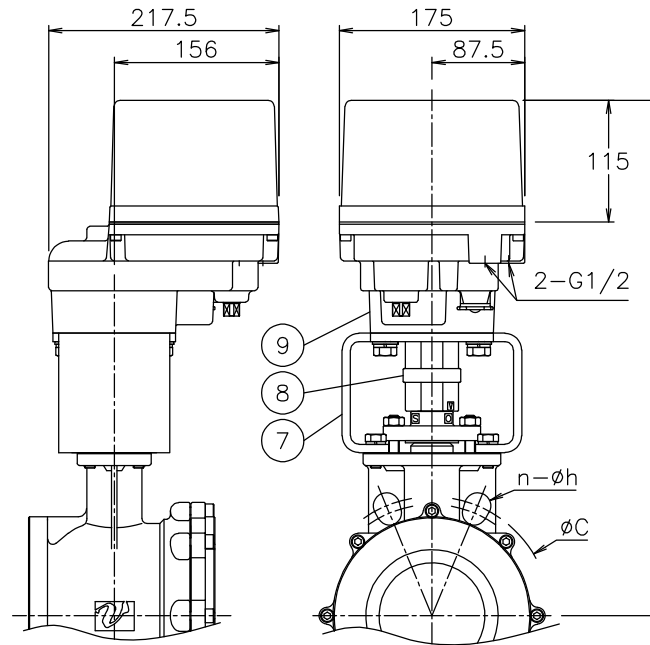
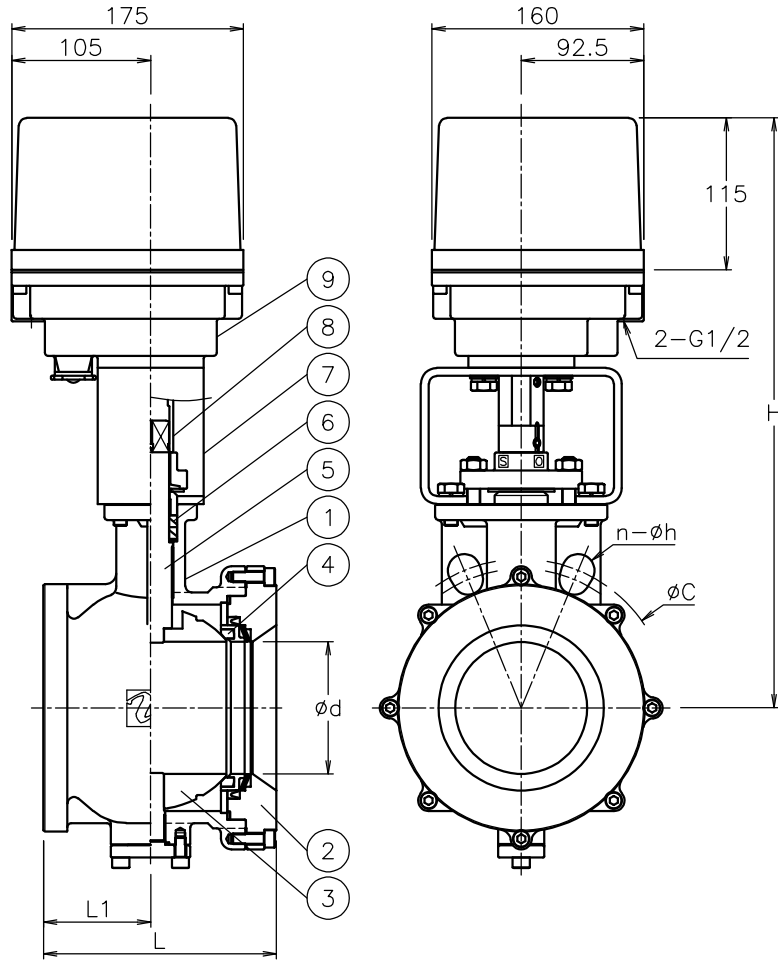

PHXGS*23UUMR125
PHRGS*23UUMR125
PDXGS*23UUMR125

NOTE
付属品
・ケーブルネット(ナイロ製), G1/2, 適合ケーブルφ6~12
・プラグ

No	DESCRIPTION	MATERIALS	REQ'D	REMARKS
9	電動操作機	アルミ压铸ケース	1	
8	コネクタ	SCS13A	1	
7	ブラケット	SUS304	1	
6	パッキン	強化PTFE	2	
5	ステム	SUS316	1	
4	シート	SUS316	1	(ステンレス盛)
3	ボール	SCS14A	1	HCr PLTD
2	キャップ	SCS14A	1	
1	本体	SCS14A	1	

MARK	DATE	BY	DATE	SCALE	NON	DWG No.	GS-*3UUM-R-PX5
REVISIONS MV-2934				APPR'D CHK'D DESIGN DRAWN	H. F K. Y S. O	TITLE MODEL	J10K/20K ウェハ-形 GS型コントロールバルブ PHXGS**3UUMR PHRGS**3UUMR PDXGS**3UUMR
						NIPPON VALVE CONTROLS, INC.	