

口径	d	L	L1	J10K		J20K		W	N	N1	H	質量 (kg)	Cv 値	操作機型式	ランク
				C	n-h	C	n-h								
15 A	15	40	20	70	4-15	70	4-15	170	82	36	224	2.3	20	TAD-050	2
20 A	20	50	25	75	4-15	75	4-15	170	82	36	226	2.5	36	TAD-050	2
25 A	25	60	30	90	4-19	90	4-19	170	82	36	235	3	50	TAD-050	0
								204	95	38	250	3.9		TAD-063	2
32 A	32	70	35	100	4-19	100	4-19	170	82	36	239	3.5	90	TAD-050	0
								204	95	38	254	4.3		TAD-063	2
40 A	40	80	40	105	4-19	105	4-19	204	95	38	277	5.3	120	TAD-063	0
								240	116	45	342	7.1		TAD-080	2
50 A	50	95	45	120	4-19	120	8-19	240	116	45	350	8.5	220	TAD-080	2
65 A	64	110	52	140	4-19	140	8-19	240	116	45	352	12	380	TAD-080	0
								294	143	57	405	15		TAD-100	2
80 A	74	125	61	150	8-19	160	8-23	294	143	57	412	17	750	TAD-100	2

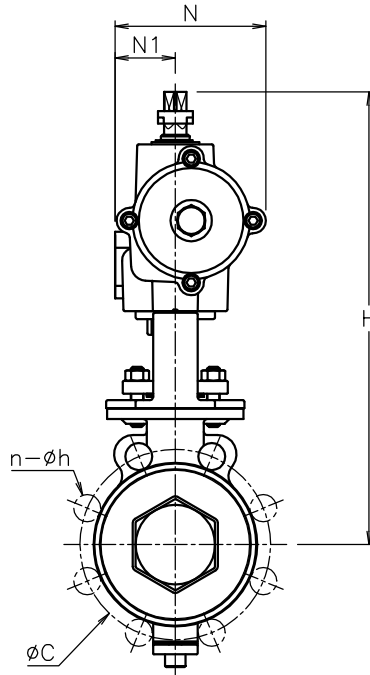
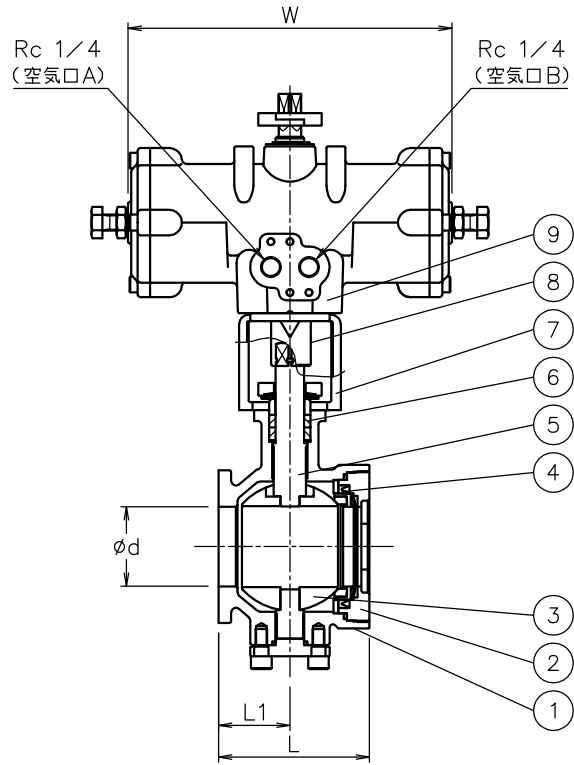

NOTE

- ① 標準操作圧力: 0.4~0.5 MPa 最大0.7 MPa
- ② 操作機動作
 - ・空気口Aへ空気導入によりバルブ閉
 - ・空気口Bへ空気導入によりバルブ開

9	エア作動操作機		1	TAD
8	コネクタ	SUS304/SCS13A	1	
7	ブラケット	SUS304/SCS13A	1	
6	パッキン	強化PTFE	2	
5	ステム	SUS316	1	
4	シート	PEEK	1	
3	ボール	SCS14A	1	HCr PLTD
2	キャップ	SCS14A	1	
1	本体	SCS14A	1	
No	DESCRIPTION	MATERIALS	REQ' D	REMARKS

			APPR' D	H. F	TITLE	J10K/20K ウェー式(複作動形) 口径: 15~80 A GS 型エア作動ボールバルブ					
			CHK' D	K. Y							
			DESIGN		MODEL	TADGS9*3UUK					
			DRAWN	K. I							
MARK	DATE	BY	DATE	'10-06-29	SCALE	NON	DWG No.	GS-9*3UUK-TA7			
REVISIONS											
MV-2241											