

呼び径	d	L	L1	J10K		J20K		W1	W2	W3	W4	W5	H	質量 (kg)	Cv値	操作機型式		ランク
				C	n-h	C	n-h									AE1-120	AE2-120	
15 A	15	40	20	70	4-15	70	4-15	122	60	145	60	102	230	3.3	20	AE1-120	AE2-120	0
														3.9		AE1-360	AE2-360	2
20 A	20	50	25	75	4-15	75	4-15	122	60	145	60	102	232	3.5	36	AE1-120	AE2-120	0
														4.1		AE1-360	AE2-360	2
25 A	25	60	30	90	4-19	90	4-19	122	60	145	60	102	241	4	50	AE1-120	AE2-120	0
														4.6		AE1-360	AE2-360	2
32 A	32	70	35	100	4-19	100	4-19	122	60	145	60	102	245	5	90	AE1-360	AE2-360	2
40 A	40	80	40	105	4-19	105	4-19	122	60	145	60	102	268	120	6	AE1-360	AE2-360	0
													284		6.1	AE1-700	AE2-700	2
50 A	50	95	45	120	4-19	120	8-19	122	60	145	60	102	276	220	7.4	AE1-360	AE2-360	0
													292		7.5	AE1-700	AE2-700	2
65 A	64	110	52	140	4-19	140	8-19	122	60	145	60	102	326	380	11	AE1-700	AE2-700	0
								160	97	175	63	115	397			17	AE1-02K	AE2-02K
80 A	74	125	61	150	8-19	160	8-23	160	97	175	63	115	404	19	750	AE1-02K	AE2-02K	2

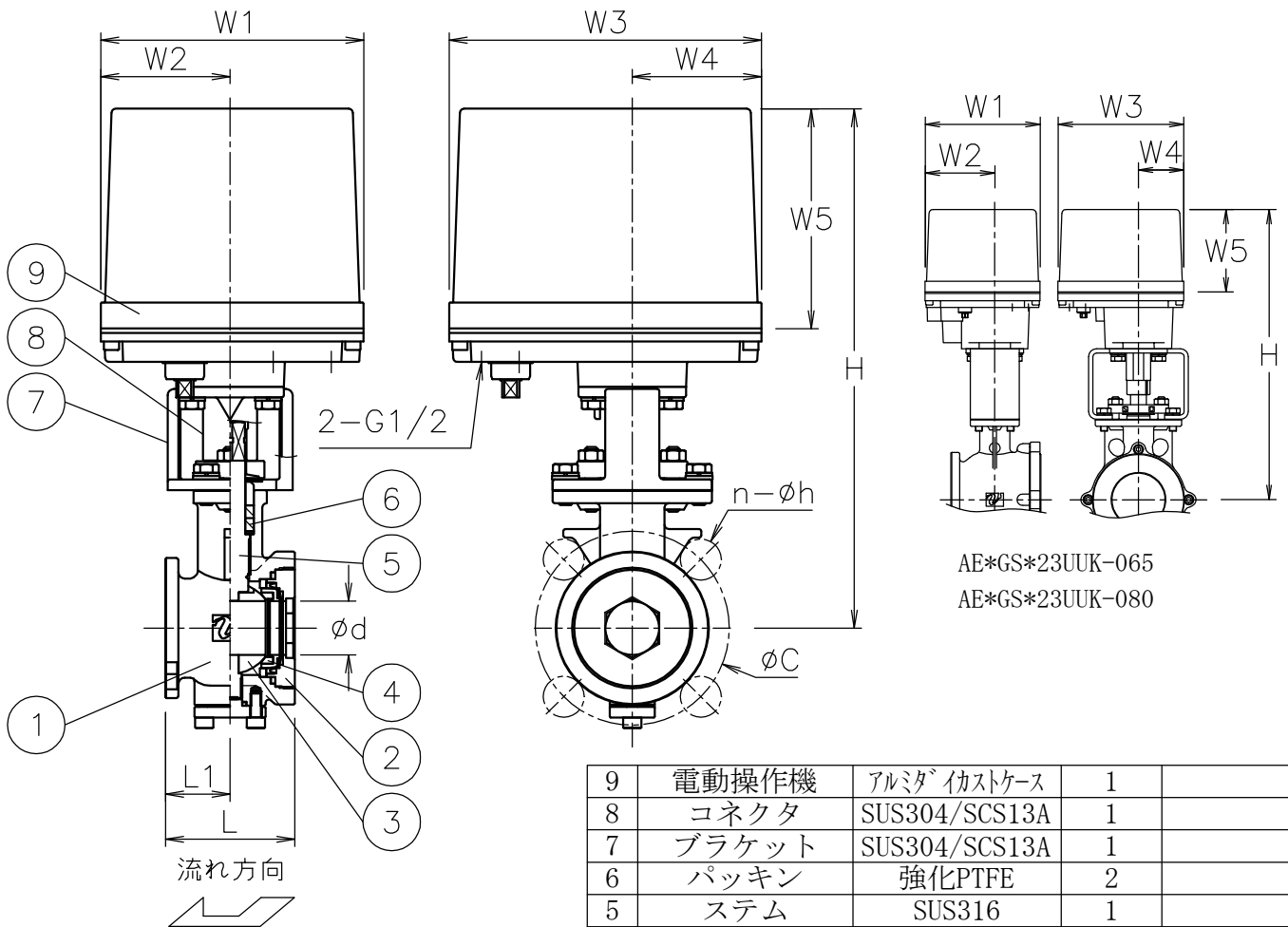

NOTE

付属品

- ・ケーブル「グラント」(ナイロン製), G1/2, 適合ケーブルφ6~12
- ・プラグ

9	電動操作機	アルミダ イラストケース	1	
8	コネクタ	SUS304/SCS13A	1	
7	ブラケット	SUS304/SCS13A	1	
6	パッキン	強化PTFE	2	
5	ステム	SUS316	1	
4	シート	PEEK	1	
3	ボール	SCS14A	1	HCr PLTD
2	キャップ	SCS14A	1	
1	本体	SCS14A	1	
No	DESCRIPTION	MATERIALS	REQ'D	REMARKS

			APPR'D	H. F	TITLE	J10K/20K ウェハー形 GS型モータボールバルブ				
			CHK'D	K. Y						
			DESIGN		MODEL	AE1GS**3UUK AE2GS**3UUK				
			DRAWN	S. O						
MARK	DATE	BY	DATE	'19-07-23	SCALE	NON	DWG No.	GS-*3UUK-AE14		
	REVISIONS									
	MV-2789									



NIPPON VALVE CONTROLS, INC.