

呼び径	d	L	L1	J10K		J20K		H	質量[kg]	Cv値	操作機型式		タンク
				C	n-h	C	n-h						
R40 A	32	80	37	105	4-19	105	4-19	368	12	95	ABR-300	HBR-300	0
R50 A	38	95	45	120	4-19	120	8-19	399	14	135	ABR-300	HBR-300	0
									14		ABR-700	HBR-700	2
R65 A	50	110	50	140	4-19	140	8-19	407	16	195	ABR-700	HBR-700	0
R80 A	64	125	57	150	8-19	160	8-23	423	20	410	ABR-700	HBR-700	0
								445	21		-	HBR-02K	2
R100 A	74	145	67	175	8-19	185	8-23	448	24	430	ABR-700	HBR-700	0
								470	26		-	HBR-02K	2
R125 A	100	176	81	210	8-23	225	8-25	499	36	900	-	HBR-02K	0
								540	42		-	HBR-06K	2
R150 A	125	215	105	240	8-23	260	12-25	517	47	1360	-	HBR-02K	1
								558	53		-	HBR-06K	0

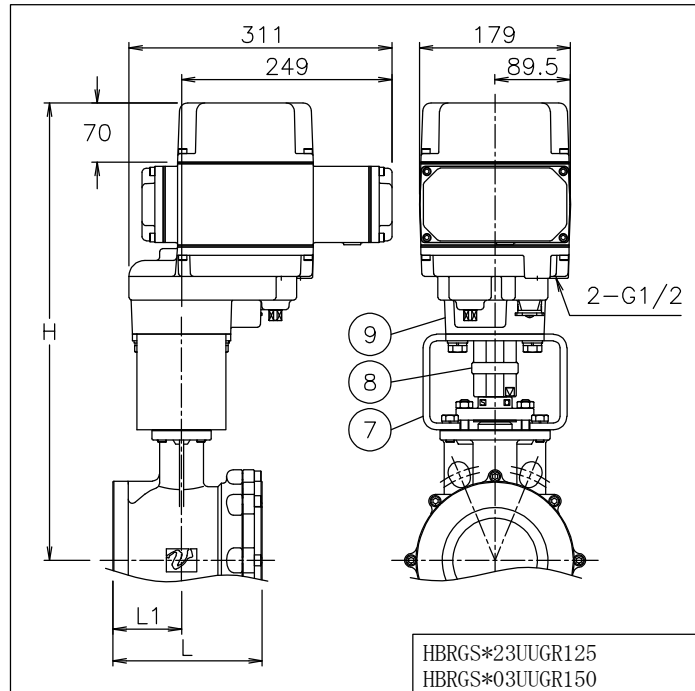
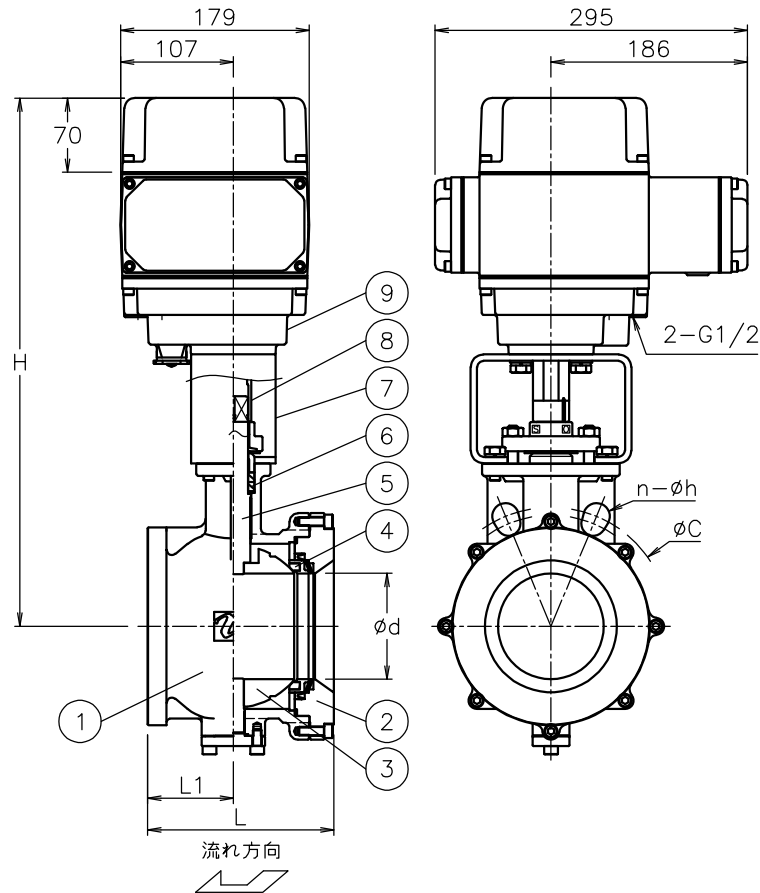

9	電動操作機	AC4C	1	
8	コネクタ	SCS13A	1	
7	ブラケット	SUS304	1	
6	パッキン	強化PTFE	2	
5	ステム	SUS316	1	
4	シート	強化PTFE	1	
3	ボール	SCS14A	1	HCr PLTD
2	キャップ	SCS14A	1	
1	本体	SCS14A	1	
No	DESCRIPTION	MATERIALS	REQ'D	REMARKS

NOTE
 付属品
 ・ケーブルクランプ (ナイロン製), G1/2, 適合ケーブルφ6~12
 ・プラグ

			APPR'D	H. F	TITLE	J10K/20K ウェハ形 GS 型電動緊急遮断型ボールバルブ								
			CHK'D	K. Y		MODEL	ABRGS**3UUGR HBRGS**3UUGR							
			DESIGN				MARK	DATE	BY	DATE	'20-04-12	SCALE	NON	DWG No.
			DRAWN	S. O										
			REVISIONS											
			MV-2898			NIPON VALVE CONTROLS, INC.								