

呼び径	d	L	D	JIS 5K		JIS 10K		W	N	N1	H	質量(kg)	Cv値	操作機型式	ランク
				C1	n1-h1	C2	n2-h2								
50 A	52	41	95	105	4-15	120	4-19	170	82	36	267	4.2	159	TAD-050	0
								204	95	38	282				
65 A	64	44	108	130	4-15	140	4-19	204	95	38	299	5.5	266	TAD-063	2
								240	116	45	348				
80 A	78	44	125	145	4-19	150	8-19	240	95	38	306	5.7	457	TAD-063	0
								240	116	45	348				
100 A	103	51	145	165	8-19	175	8-19	240	116	45	376	8.3	860	TAD-080	0
								294	143	57	407				
125 A	129	54	186	200	8-19	210	8-23	240	116	45	376	11	1320	TAD-080	0
								294	143	57	407				
150 A	154	54	210	230	8-19	240	8-23	294	143	57	420	15	2020	TAD-100	0
200 A	200	60	256	280	8-23	290	12-23	366	150	60	486	26	3540	TAD-125	0

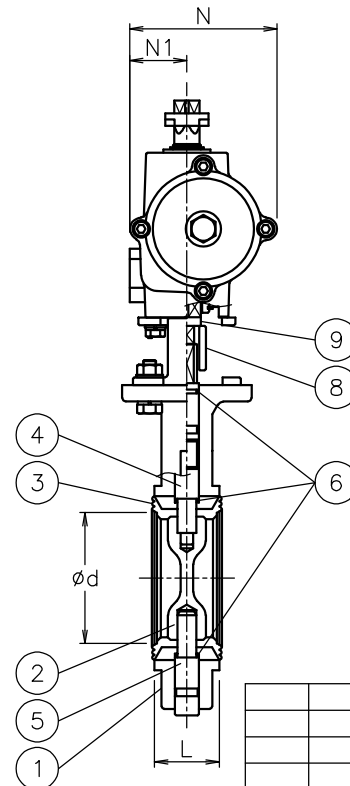
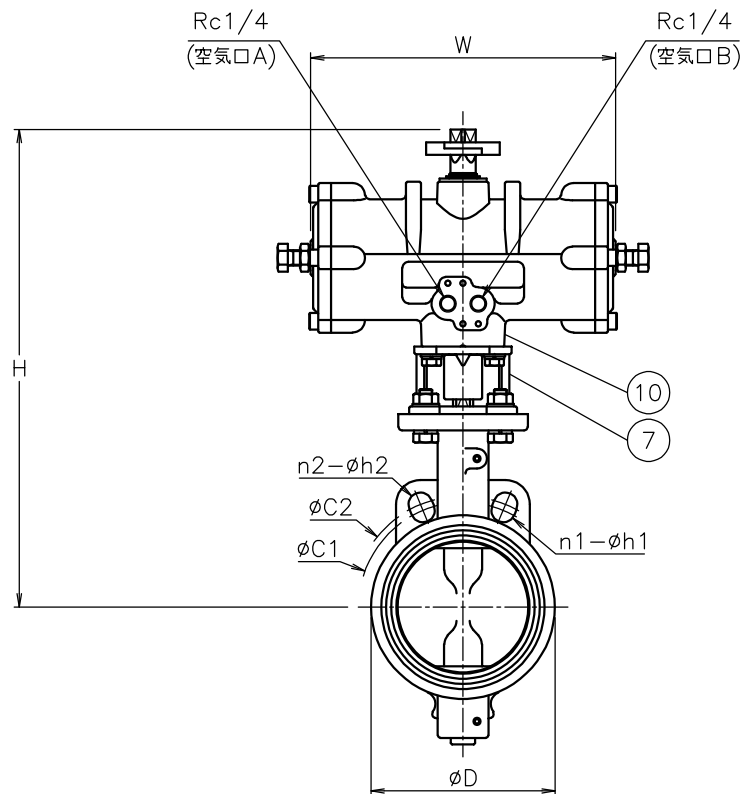

NOTE

- ① 標準操作圧力: 0.4~0.5MPa 最大0.7MPa
- ② 操作機動作
 空気口Aへ空気導入によりバルブ閉
 空気口Bへ空気導入によりバルブ開

No	DESCRIPTION	MATERIALS	REQ'D	REMARKS
10	エア作動操作機		1	TAD
9	コネクタ	SUS304	1	
8	コネクタ	SUS304/SCS13A	1	
7	ブラケット	SCS13A	1	
6	Oリング	NBR	3	
5	ピン	SUS403	1	
4	ステム	SUS403	1	
3	シート	NBR	1	
2	弁体	FCD450	1	無電解Niメッキ
1	本体	FCD450	1	

MARK	DATE	BY	DATE	SCALE	NON	DWG No.	FN-9*1DDB-TA6
REVISIONS							
MV-2991							



NIPON VALVE CONTROLS, INC.