

呼び径	d	L	C	n-m	H1	H	質量(kg)	Cv値	操作機型式		ランク
40 A	45	33	105	4-M16	53	400	11	101	ABR-300	HBR-300	0
50 A	55	43	120	4-M16	61	415	12	236	ABR-300	HBR-300	0
65 A	65	46	140	4-M16	69	425	12	313	ABR-300	HBR-300	0
80 A	80	46	150	8-M16	79	435	13	469	ABR-700	HBR-700	0
100 A	99	52	175	8-M16	94	450	13	777	ABR-700	HBR-700	0
125 A	124	56	210	8-M20	109	470	15	1251	ABR-700	HBR-700	1
						492			-	HBR-02K	0
150 A	150	56	240	8-M20	124	507	17	2372	-	HBR-02K	0
						537			-	HBR-02K	0
200 A	200	60	290	12-M20	160	578	26	4480	-	HBR-06K	2
						578			-	HBR-06K	2
250 A	251	68	355	12-M22	207	616	32	6830	-	HBR-06K	0
300 A	298	78	400	16-M22	233	652	37	9280	-	HBR-06K	0

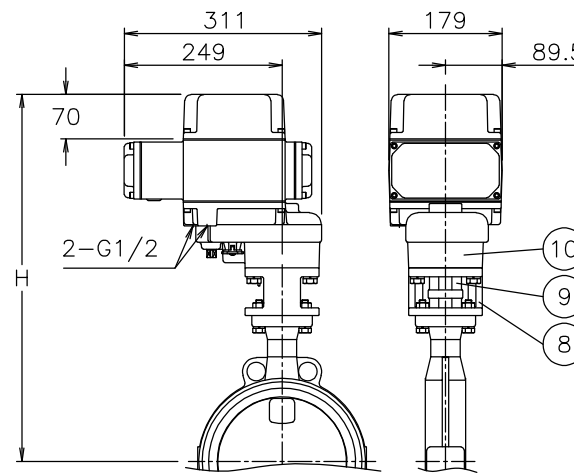

HBRFE*21LTB-200
HBRFE*01LTB-250
HBRFE*01LTB-300

NOTE

付属品

- ・ケーブルラッド (ナイロ製), G1/2, 適合ケーブルφ6~12
- ・プラグ

No	DESCRIPTION	MATERIALS	REQ'D	REMARKS
10	電動操作機	AC4C	1	
9	コネクタ	SCS13A	1	
8	ブラケット	SCS13A	1	
7	リング	NBR	1set	
6	リング	NBR	1	
5	ピン	SUS410	1	
4	ステム	SUS410	1	
3	シート	NBR	1	
2	弁体	SCS13A	1	
1	本体	ADC12	1	

MARK	DATE	BY	DATE	SCALE	NON	DWG No.	FE-*1LTB-AB2
REVISIONS							
MV-3018							
				APPR'D	H. F	TITLE	
				CHK'D	K. Y	J10Kウェハー形 FE型電動緊急遮断型バタフライバルブ	
				DESIGN		MODEL	
				DRAWN	S. O	ABRFE**1LTB HBRFE**1LTB	
					'23-06-23	FE-*1LTB-AB2	



NIPON VALVE CONTROLS, INC.