

呼び径	d	L	D	C	n-h	W	N	N1	H	質量(kg)	Cv値	操作機型式	ランク
50 A	52	41	115	120	4-19	170	82	36	267	3.4	159	TAD-050	0
65 A	64	44	135	140	4-19	204	95	38	299	5.7	266	TAD-063	0
80 A	78	44	145	150	8-19	204	95	38	306	6	457	TAD-063	0
						240	116	45	348	7.7		TAD-080	2
100 A	103	51	175	175	8-19	240	116	45	376	9.4	860	TAD-080	0
125 A	129	54	206	210	8-23	240	116	45	376	11	1320	TAD-080	0
						294	143	57	407	14		TAD-100	2
150 A	154	54	231	240	8-23	294	143	57	420	15	2020	TAD-100	0
200 A	205	64	290	290	12-23	366	150	60	486	27	3540	TAD-125	0
						446	181	68	554	37		TAD-160	2
250 A	254	64	350	355	12-25	446	181	68	586	43	5580	TAD-160	0
300 A	305	76	414	400	16-25	446	181	68	624	78	8080	TAD-160	1

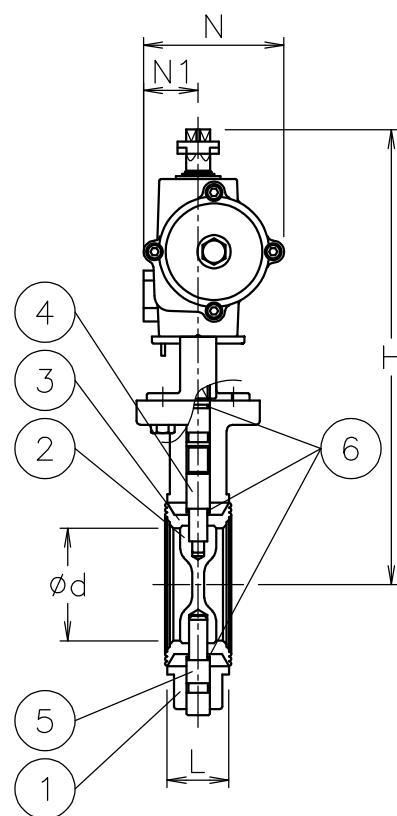
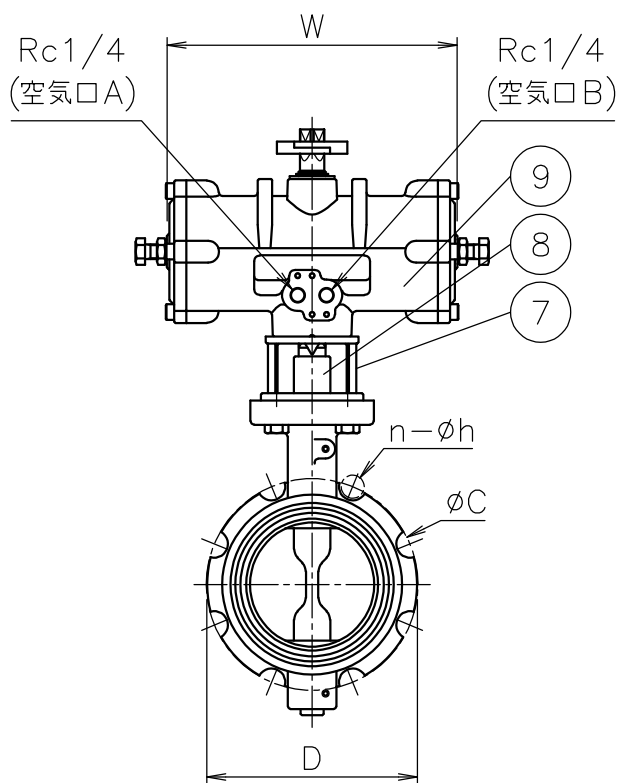

NOTE

- ① 標準操作圧力: 0.4~0.5MPa 最大0.7MPa
- ② 操作機動作
空気口Aへ空気導入によりバルブ閉
空気口Bへ空気導入によりバルブ開

9	エア作動操作機		1	TAD
8	コネクタ	SUS304/SCS13A	1	
7	ブラケット	SCS13A	1	
6	Oリング	FKM	3	
5	ピン	SUS403	1	
4	ステム	SUS403	1	
3	シート	FKM	1	
2	弁体	SCS14/SUSF316	1	
1	本体	FCD450	1	
No	DESCRIPTION	MATERIALS	REQ'D	REMARKS

			APPR'D	K. Y	TITLE	J10K ウェハー形 (複作動形) F型エア作動バタフライバルブ		
			CHK'D	K. Y				
			DESIGN		MODEL	TADF-9*1DUV		
			DRAWN	S. O				
MARK	DATE	BY	DATE	'24-04-04	SCALE	NON	DWG No.	F-9*1DUV-TA2
REVISIONS			 NIPPON VALVE CONTROLS, INC.					
MV-3062								