

呼び径	S	d	L	h1	h2	H1	H	質量 (kg)	Cv値	操作機型式		ランク
15 A	Rc 1/2	13	59	36	58	52	151	1.4	9	AM1-030	AM2-030	0
20 A	Rc 3/4	15	66	36	58	54	153	1.5	13	AM1-030	AM2-030	0
25 A	Rc 1	20	78	36	58	61	160	1.7	24	AM1-070	AM2-070	0
				53	85		202	2.2		AM1-180	AM2-180	2
32 A	Rc1 1/4	25	87	36	58	71	170	2	44	AM1-070	AM2-070	0
				53	85		212	2.5		AM1-180	AM2-180	2
40 A	Rc1 1/2	32	95	53	85	77	218	2.9	80	AM1-180	AM2-180	0
50 A	Rc 2	40	109	53	85	83	224	3.5	120	AM1-180	AM2-180	0

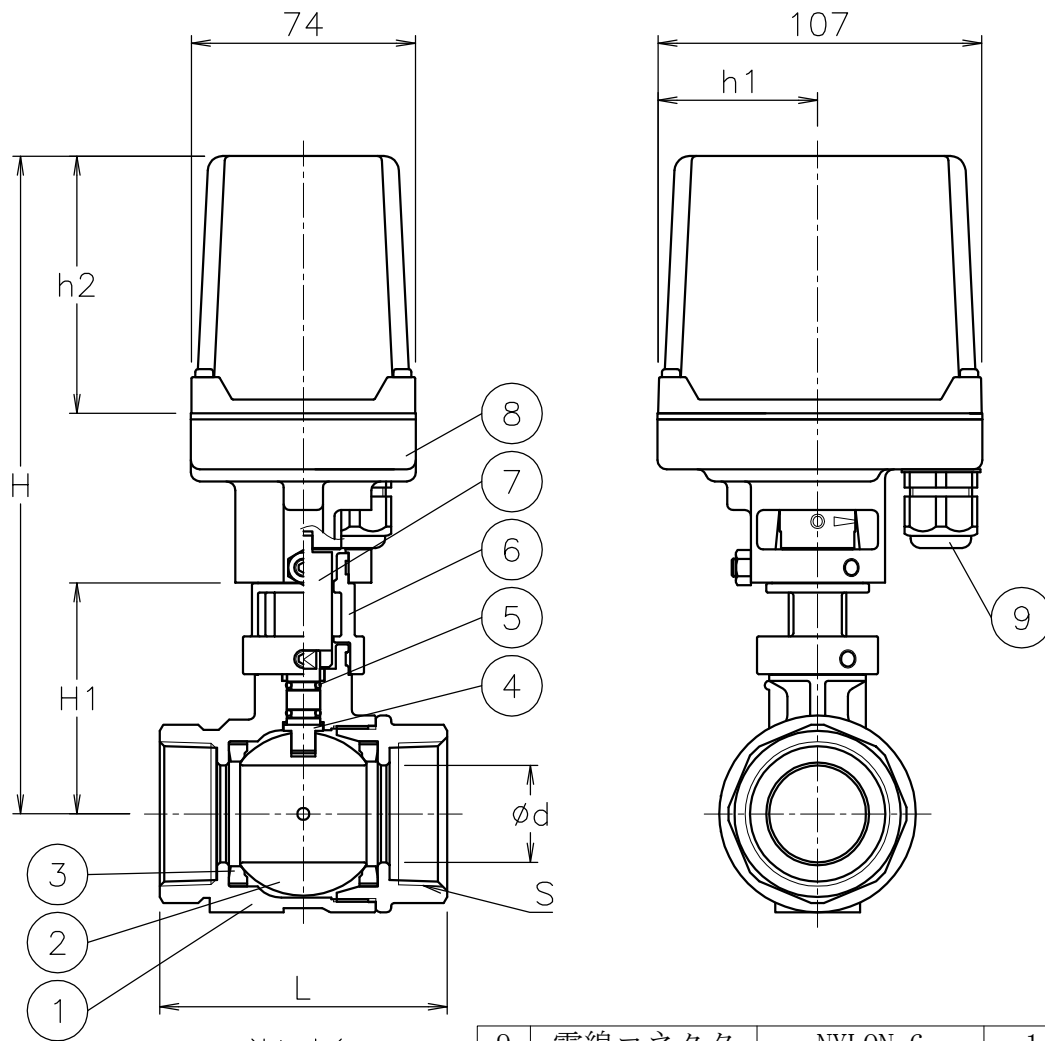

流れ方向

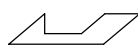

NOTE

(a) ケーブルコネクタの適合ケーブル外径はφ5~10.5

9	電線コネクタ	NYLON 6	1	G 3/8 (a)
8	電動操作機	ADC12/PC CASE	1	
7	コネクタ	SUS303	1	
6	ブラケット	SCS13A	1	
5	Oリング	耐蒸気FKM	2	
4	ステム	SUS316	1	メッキ
3	シート	強化PTFE	2	
2	ボール	SCS14A	1	
1	本体	SCS14A	1	
No	DESCRIPTION	MATERIALS	REQ' D	REMARKS

			APPR' D	H. F	TITLE	R c ねじ込み式 EG型モータボールバルブ					
			CHK' D	K. Y							
			DESIGN		MODEL	AM1EG**5UUP AM2EG**5UUP					
			DRAWN	S. O							
MARK	DATE	BY	DATE	'16-11-11	SCALE	NON	DWG No.	EG-*5UUP-AM6			
REVISIONS			 NIPPON VALVE CONTROLS, INC.								
MV-2565											