

呼び径	d	L	D	J5K		J10K		H1	H	質量 (kg)	Cv値	操作機型式	ランク
				C	n-h	C	n-h						
80 A	78	46	126	145	4-19	150	8-19	90	410	14	220	PBX-300	0
										14		PBX-700	2
100 A	98	52	146	165	8-19	175	8-19	107	440	15	410	PBX-700	0
125 A	126	56	180	200	8-19	210	8-23	129	455	17	800	PBX-700	0
										19		PBX-02K	2
150 A	150	56	211	230	8-19	240	8-23	147	502	23	1250	PBX-02K	0
200 A	196	60	257	280	8-23	290	12-23	189	532	28	2450	PBX-02K	0
250 A	246	68	322	345	12-23	355	12-25	222	608	43	4250	PBX-06K	0
300 A	295	78	367	390	12-23	400	16-25	260	648	53	6750	PBX-06K	0

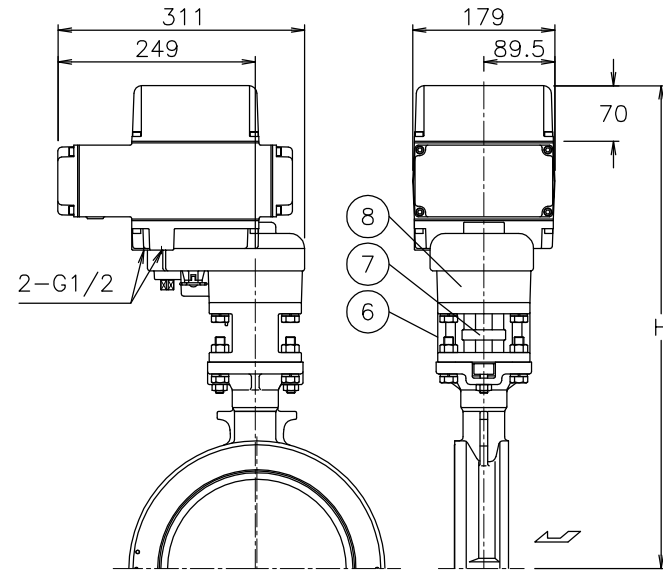

PBXDN*01TTF-250
PBXDN*01TTF-300

NOTE

付属品

- ・ケーブルコネクタ(ナイロン製), G1/2, 適合ケーブルφ6~12
- ・プラグ

No	DESCRIPTION	MATERIALS	REQ'D	REMARKS
8	電動操作機	AC4C	1	
7	コネクタ	SCS13A	1	
6	ブラケット	SCS13A	1	
5	パッキン	PTFE	1	
4	ステム	SUS304	1	
3	シート	F-PTFE	1	
2	弁体	SCS13A	1	
1	本体	SCS13A	1	

MARK	DATE	BY	DATE	APP'R D	H. F	TITLE					
				CHK' D	K. Y	J5K/10Kウエハー式 DN型電動緊急遮断型コントロールバルブ					
				DESIGN		MODEL	PBXDN**1TTF				
				DRAWN	S. O	SCALE	NON	DWG No.	DN-*1TTF-BX2		
				DATE	'17-04-14						
REVISIONS											
MV-2608											