

呼び径	d	L	D	J5K		J10K		H1	W1	W2	φK	H	質量 (kg)	Cv値	操作機型式
				C	n-h	C	n-h								
80 A	78	46	126	145	4-19	150	8-19	90	157	45	150	165	7.6	220	MAG-F07
100 A	98	52	146	165	8-19	175	8-19	107	157	45	150	195	9	410	MAG-F07
125 A	126	56	180	200	8-19	210	8-23	129	157	45	150	210	11	800	MAG-F07
150 A	150	56	211	230	8-19	240	8-23	147	157	45	150	235	15	1250	MAG-F07
200 A	196	60	257	280	8-23	290	12-23	189	240	63	300	267	25	2450	MAG-F10
250 A	246	68	322	345	12-23	355	12-25	222	226	78	300	299	39	4250	MAG-F12
300 A	295	78	367	390	12-23	400	16-25	260	226	78	300	339	48	6750	MAG-F12

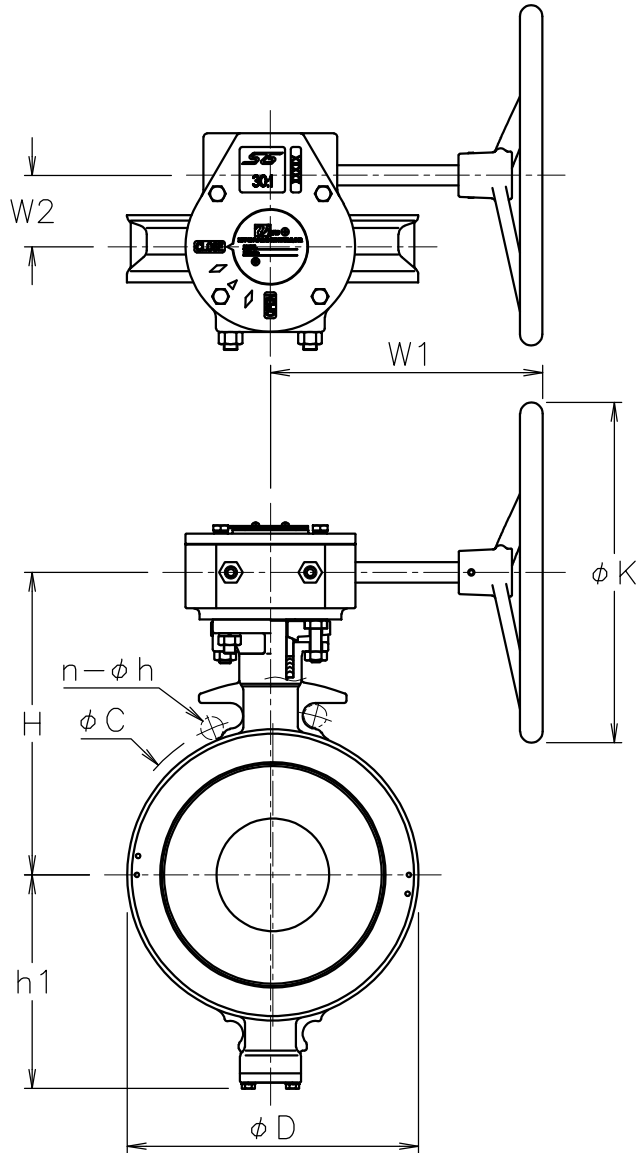

型式	減速比
MAG-F07	24:1
MAG-F10	30:1
MAG-F12	50:1

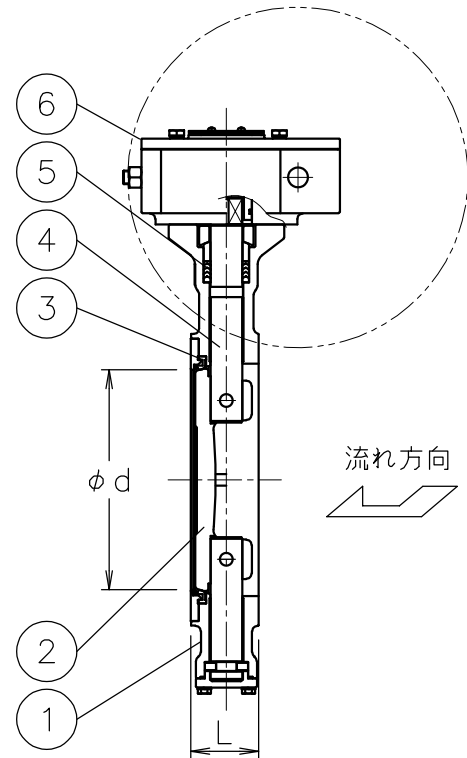

NOTE

(a) ギアのハンドルは取り外した状態で出荷
MAG-F07, MAG-F10 : FC250
MAG-F12 : FC200

6	ギア	FC200/FC250 (ケース)	1	(a)
5	パッキン	PTFE	1	
4	ステム	SUS304	1	
3	シート	F-PTFE	1	
2	弁体	SCS13A	1	
1	本体	SCS13A	1	
No	DESCRIPTION	MATERIALS	REQ'D	REMARKS

			APPR'D	H. F	TITLE	J5K/10K ウエハー式 DN 型手動バタフライバルブ				
			CHK'D	K. Y						
			DESIGN		MODEL	MA-DNG-1TTF				
			DRAWN	P. O						
MARK	DATE	BY	DATE	'20-12-24	SCALE	NON	DWG No.	DN-1TTF-G-MA5		
REVISIONS			 NIPPON VALVE CONTROLS, INC.							
MV-2876										