

呼び径	d	L	L1	D	C	n-h	W1	W2	φK	H2	質量 (kg)	操作機型式
65 A	65	190	85	175	140	4-19	157	45	150	140	17	MAG-F07
80 A	80	203	97	185	150	8-19	157	45	150	152	20	MAG-F07
100 A	100	229	109	210	175	8-19	240	63	300	180	33	MAG-F10
125 A	125	356	150	250	210	8-23	240	63	300	198	52	MAG-F10
150 A	150	394	152	280	240	8-23	226	78	300	221	75	MAG-F12

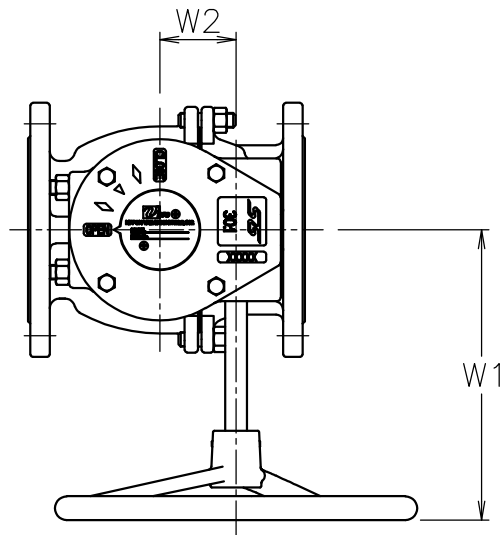

型式	減速比
MAG-F07	24:1
MAG-F10	30:1
MAG-F12	50:1

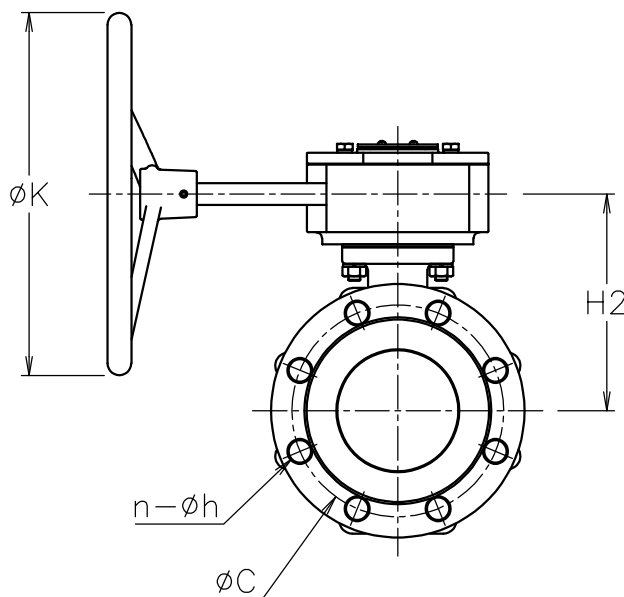
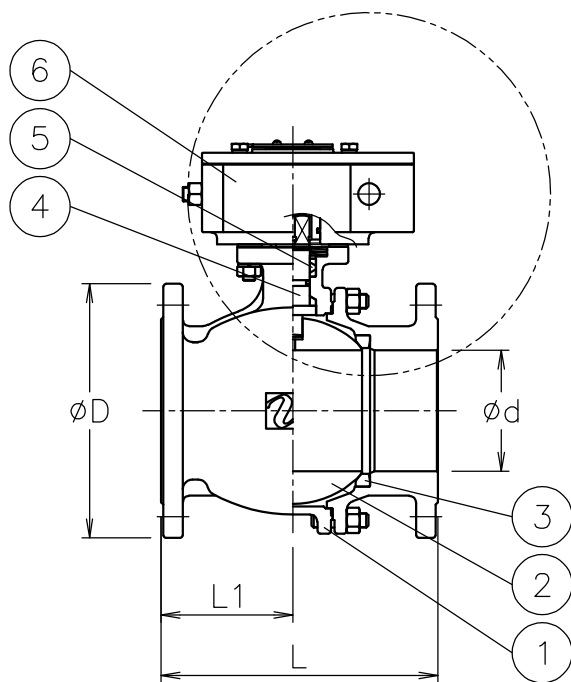

NOTE

(a) ギアのハンドルは取り外した状態で出荷
MAG-F07, MAG-F10 : FC250
MAG-F12 : FC200

※標準仕様ではステムの2次シールとしてFKMのOリングが付いています

6	ギア	FC200/FC250 (ケース)	1	(a)
5	パッキン	強化PTFE	1set	
4	ステム	SUS304	1	
3	シート	強化PTFE	2	
2	ボール	SCS13A	1	
1	本体	SCS13A	1	
No	DESCRIPTION	MATERIALS	REQ'D	REMARKS

			APPR'D	H. F	TITLE	J10Kフランジ式 BR型手動ボールバルブ					
			CHK'D	K. Y							
			DESIGN		MODEL	MAXBRG-1TTG					
			DRAWN	P. O							
MARK	DATE	BY	DATE	'20-12-24	SCALE	NON	DWG No.	BR-1TTG-G-MA6			
REVISIONS			 NIPPON VALVE CONTROLS, INC.								
MV-2876											