

呼び径	d	L	L1	D	C	n-h	H	質量 (kg)	操作機型式			ランク
15 A	13	140	63	95	70	4-15	281	8.7	AD1-300	AD2-300	AD0-300	0
20 A	19	152	70	100	75	4-15	285	9.4	AD1-300	AD2-300	AD0-300	0
25 A	25	165	71	125	90	4-19	296	12	AD1-300	AD2-300	AD0-300	0
32 A	38	190	76.5	135	100	4-19	321	14	AD1-300	AD2-300	AD0-300	0
								15	AD1-700	AD2-700	AD0-700	2
40 A	38	190	76.5	140	105	4-19	321	14	AD1-300	AD2-300	AD0-300	0
								15	AD1-700	AD2-700	AD0-700	2
50 A	51	216	86	155	120	8-19	329	17	AD1-700	AD2-700	AD0-700	0
65 A	64	241	103	175	140	8-19	368	25	AD1-700	AD2-700	AD0-700	0
80 A	76	283	124	200	160	8-23	378	31	AD1-700	AD2-700	AD0-700	1

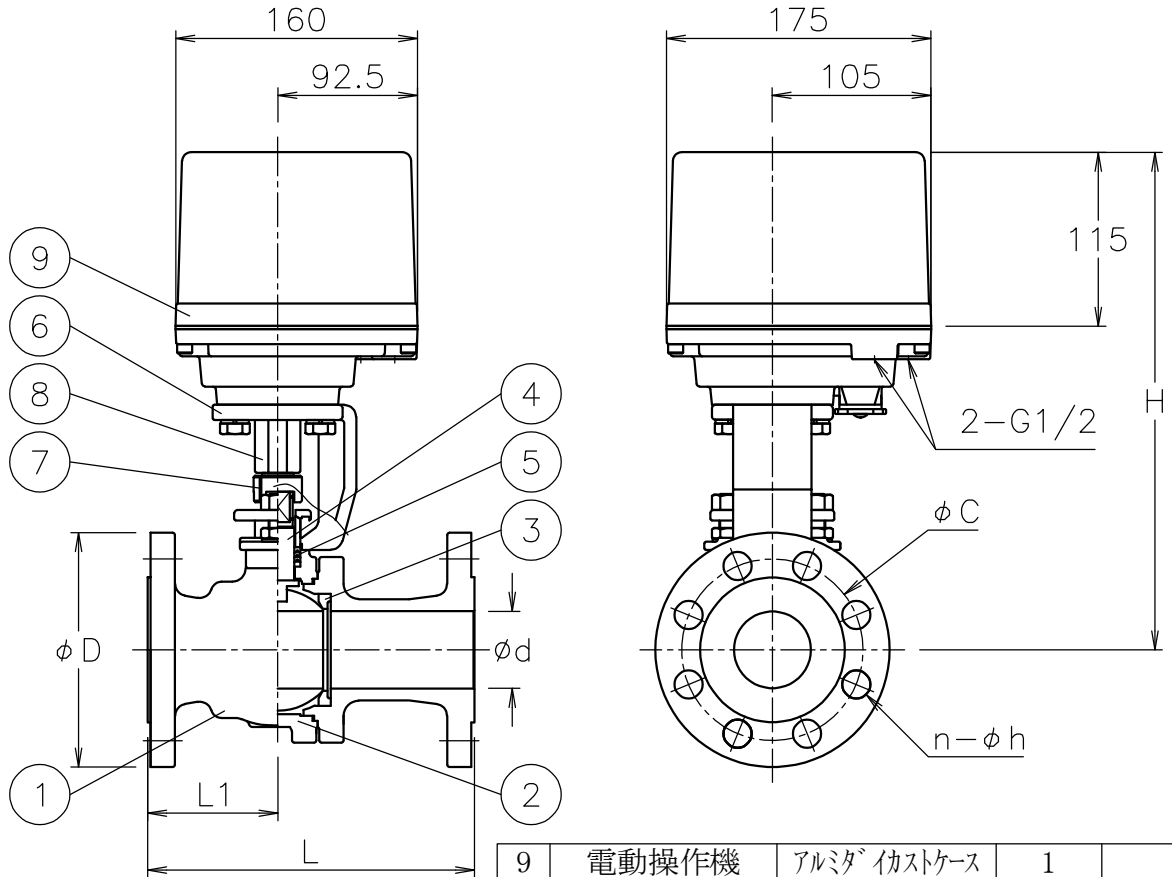

NOTE

付属品

- ・ケーブルコネクタ(ナイロン製), G 1/2, 適合ケーブルφ6~12
- ・プラグ

9	電動操作機	アルミダイカストケース	1	
8	コネクタ	SCS13A	1	
7	コネクタ	SUS304	1	065, 080A
		SCS13A		025~050A
		S45C		015, 020A
6	ブラケット	SCPH2	1	
5	パッキン	N-PTFE	1	
4	ステム	SUS304	1	
3	シート	N-PTFE	2	
2	ボール	SUS304/SCS13A	1	
1	本体	SCS13A	1	
No	DESCRIPTION	MATERIALS	REQ'D	REMARKS

			APPR'D	H. F	TITLE	J20Kフランジ式 BF型モータボールバルブ			
			CHK'D	K. Y					
			DESIGN		MODEL	AD1BF**3TTT AD0BF0*3TTT AD2BF**3TTT			
			DRAWN	P. O					
MARK	DATE	BY	DATE	'21-08-05	SCALE	NON	DWG No.	BF-*3TTT-AD10	
REVISIONS			 NIPPON VALVE CONTROLS, INC.						
MV-2919									