

AE*BF*23TTG-100

AE*BF*23TTG-065
AE*BF*03TTG-080
AE*BF*03TTG-100

AE*BF*03TTG-065

呼び径	d	L	L1	D	C	n-h	N1	N2	N3	N4	N5	H	質量 (kg)	操作機型式		ランク
15 A	13	140	63	95	70	4-15	122	60	145	60	102	215	4.8	AE1-120	AE2-120	0
20 A	19	152	70	100	75	4-15	122	60	145	60	102	219	5.5	AE1-120	AE2-120	0
25 A	25	165	71	125	90	4-19	122	60	145	60	102	229	7.2	AE1-120	AE2-120	0
													7.8	AE1-360	AE2-360	2
32 A	38	190	76.5	135	100	4-19	122	60	145	60	102	248	11	AE1-360	AE2-360	0
40 A	38	190	76.5	140	105	4-19	122	60	145	60	102	248	11	AE1-360	AE2-360	0
50 A	51	216	86	155	120	8-19	122	60	145	60	102	256	14	AE1-360	AE2-360	0
												272	14	AE1-700	AE2-700	2
65 A	64	241	103	175	140	8-19	122	60	145	60	102	300	21	AE1-700	AE2-700	0
							160	97	175	63	115	395	27	AE1-02K	AE2-02K	2
80 A	76	283	124	200	160	8-23	160	97	175	63	115	405	33	AE1-02K	AE2-02K	0
							160	97	175	63	115	441	49	AE1-02K	AE2-02K	0
100 A	102	305	135	225	185	8-23	195	75	220	75	130	446	56	AE1-06K	AE2-06K	2
125 A	127	381	158	270	225	8-25	195	75	220	75	130	485	82	AE1-06K	AE2-06K	0
150 A	152	403	178	305	260	12-25	195	75	220	75	130	505	105	AE1-06K	AE2-06K	0

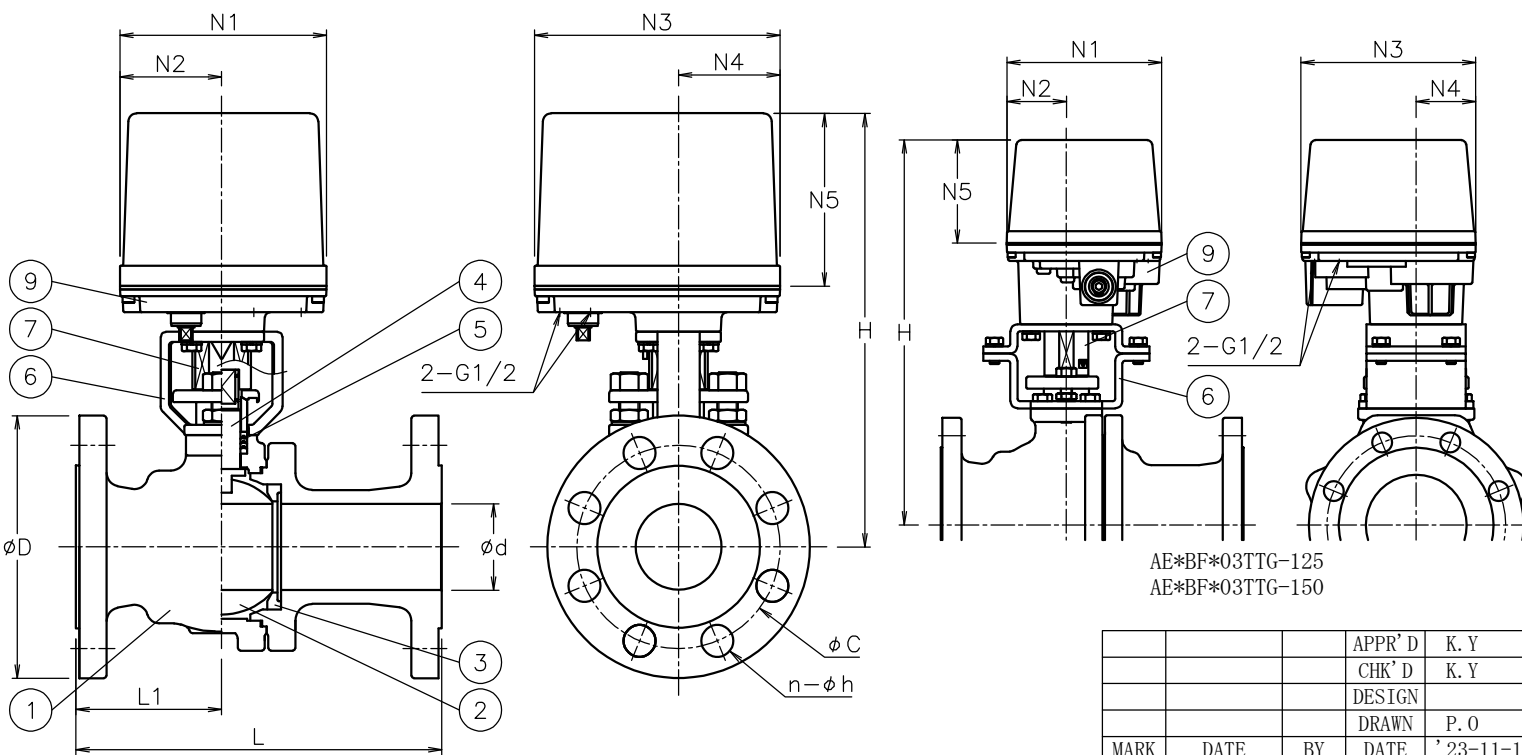

AE*BF*03TTG-125
AE*BF*03TTG-150

NOTE
付属品
・ケーブルグランド[®] (ナイロン製), G1/2, 適合ケーブルφ6~12
・プラグ

No	DESCRIPTION	MATERIALS	REQ'D	REMARKS
9	電動操作機	アルミダイカストケース	1	
8	コネクタ	SCS13A	1	
7	コネクタ	SUSXM7/LAK52	1	100A (77/2) 125, 150A
		SUS304		100A (77/2)
		SUS (LAK52) / SUS304		065, 080A
		SUS (LAK52)		015~050A
6	ブラケット	SS400	1	125, 150A
		SCPH2		100A
		SCPH2/SUS304		065, 080A
		SCS13A		015~050A
5	パッキン	N-PTFE	1	
4	ステム	SUS304	1	
3	シート	強化PTFE	2	
2	ボール	SUS304/SCS13A	1	
1	本体	SCS13A	1	

APPR'D	K. Y	TITLE	J20Kフランジ形 BF型モータボールバルブ			
CHK'D	K. Y	MODEL	AE1BF**3TTG AE2BF**3TTG			
DESIGN		SCALE	NON	DWG No.	BF-*3TTG-AE10	
DRAWN	P. O	MARK	DATE	BY	'23-11-16	
REVISIONS						
MV-3039						