

Valve DN	d	L	D	C	n-h	H	Weight (kg)	Cv	ACTUATOR			Sizing code
40 A	40	40	80	95	4-15	331	7.2	85	PHX-300	PHR-300	PDX-300	0
50 A	50	40	90	105	4-15	336	7.3	145	PHX-300	PHR-300	PDX-300	0
65 A	65	40	115	130	4-15	348	7.7	290	PHX-300	PHR-300	PDX-300	0
80 A	80	50	126	145	4-19	380	8.6	450	PHX-300	PHR-300	PDX-300	0
100 A	105	50	146	165	8-19	391	8.8	780	PHX-300	PHR-300	PDX-300	0
125 A	130	50	181	200	8-19	408	9.6	1200	PHX-300	PHR-300	PDX-300	0
150 A	154	50	211	230	8-19	423	11	1800	PHX-300	PHR-300	PDX-300	0
200 A	204	50	257	280	8-23	446	13	3200	PHX-300	PHR-300	PDX-300	0
250 A	253	50	322	345	12-23	468	17	5100	PHX-300	PHR-300	PDX-300	0
							17		PHX-700	PHR-700	PDX-700	2
300 A	300	55	367	390	12-23	494	19	7200	PHX-300	PHR-300	PDX-300	0
							19		PHX-700	PHR-700	PDX-700	2
350 A	340	70	410	435	12-25	545	29	8900	PHX-700	PHR-700	PDX-700	0
						567			31	PHX-02K	PHR-02K	PDX-02K
400 A	387	70	470	495	16-25	569	34	11000	PHX-700	PHR-700	PDX-700	0
						591			36	PHX-02K	PHR-02K	PDX-02K

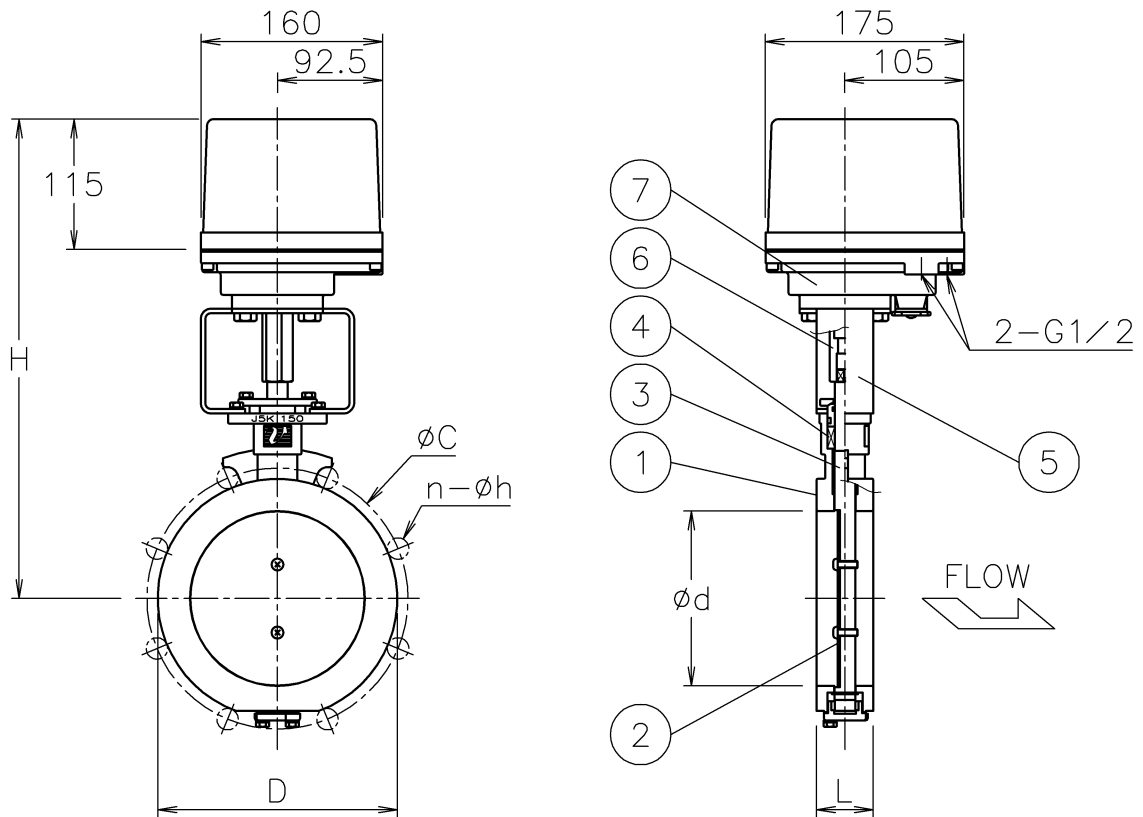

NOTE

(a) Aluminum alloy die cast cover

Attachment

- Cable gland (nylon), G1/2, for ø6~12 cable
- Plug

7	Actuator	(a)	1	
6	Joint	SCS13A	1	
5	Bracket	SUS304	1	
4	Gland Packing	GRAPHITE	1	
3	Stem	SUS420J2	1	
2	Disk	SUS420J2/420J1	1	
1	Body	SCS13A	1	
No	DESCRIPTION	MATERIALS	REQ'D	REMARKS

			APPR'D	H.F	TITLE	Valve DN: 40~400 A J5K Flanged-end (wafer type) WT type electric actuated control damper						
			CHK'D	K.Y								
			DESIGN									
			DRAWN	S.O	MODEL	PHXWT**2TG0, PHRWT**2TG0, PDXWT**2TG0						
MARK	DATE	BY	DATE	'08-07-31	SCALE	NON	DWG No.	WT-*2TG0-PX6-E				
REVISIONS												
MV-2142												