

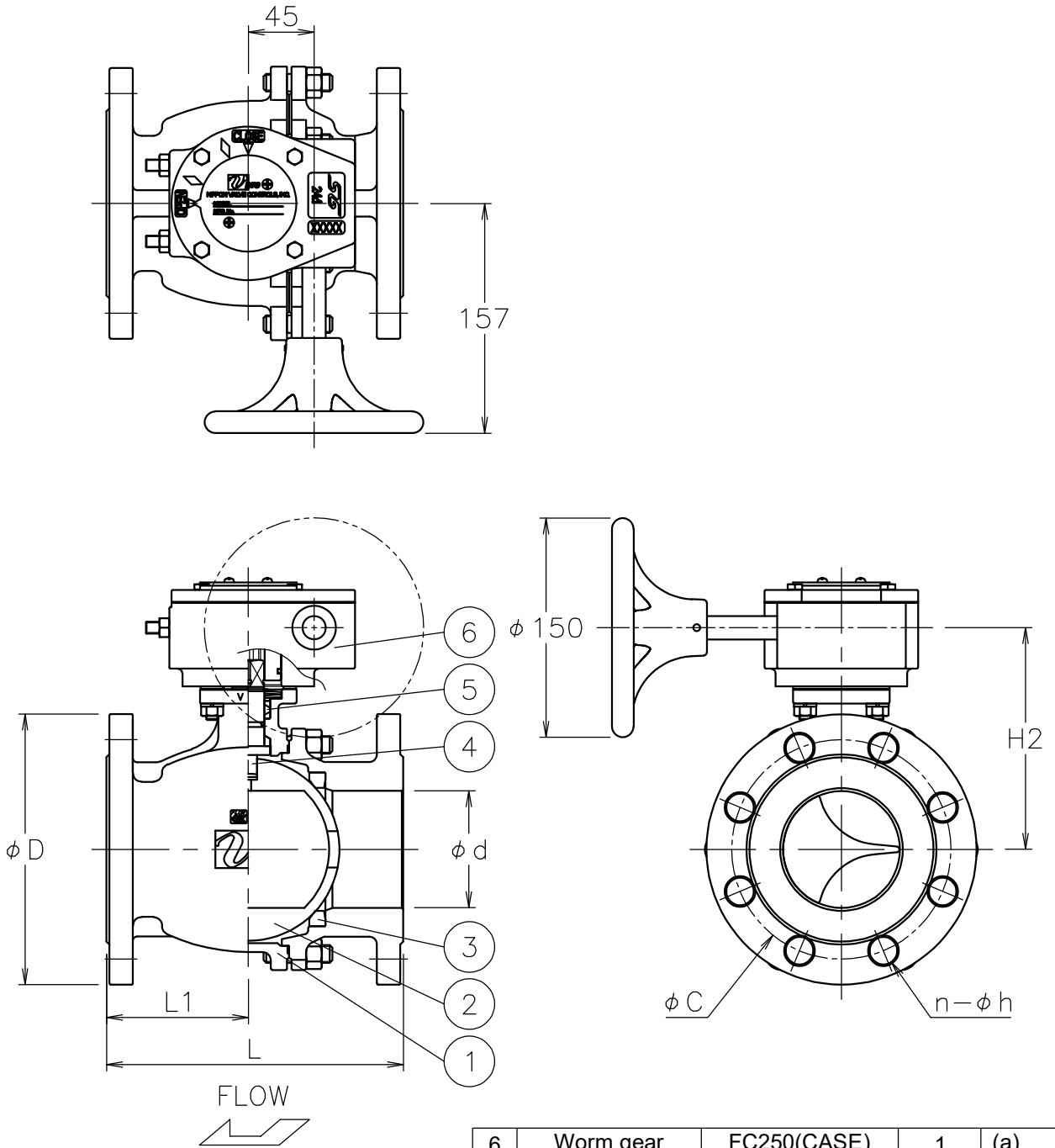

Size (mm)	d	L	L1	D	C	n-h	H2	Weight (kg)	Cv	Actuator	Reduction ratio
65 A	(65)	190	85	175	140	4-19	140	17	85	MAG-F07	24:1
80 A	(80)	203	97	185	150	8-19	152	20	123	MAG-F07	24:1



NOTE  
(a) Handle is removed and shipped.

6	Worm gear	FC250(CASE)	1	(a)
5	Packing	R-PTFE	1set	
4	Stem	SUS316	1	
3	Seat	R-PTFE	2	
2	Ball	SCS14A	1	
1	Body	SCS14A	1	
No	DESCRIPTION	MATERIALS	REQ'D	REMARKS

			APPR'D	H.F	TITLE	J10K Flanged-end VR type Ball valve					
			CHK'D	K.Y							
			DESIGN		MODEL	MAXVRG-1UUG					
			DRAWN	P.O							
MARK	DATE	BY	DATE	'20-12-25	SCALE	NON	DWG No.	VR-1UUG-G-MA3-EN			
REVISIONS			 <b>NIPPON VALVE CONTROLS, INC.</b>								
MV-2876											