

Size [mm]	d	L	L1	D	C	n-h	H	Weight [kg]	Cv	Actuator			Sizing code
25	25	127	72	125	90	4-19	310	11	28	PHX-300	PHR-300	PDX-300	0
								11		PHX-700	PHR-700	PDX-700	2
40	38	165	95	140	105	4-19	346	14	75	PHX-300	PHR-300	PDX-300	1
								14		PHX-700	PHR-700	PDX-700	0
50	51	178	103	155	120	4-19	352	15	153	PHX-700	PHR-700	PDX-700	0
65	64	190	110	175	140	4-19	398	21	250	PHX-700	PHR-700	PDX-700	1
								23		PHX-02K	PHR-02K	PDX-02K	0
80	76	203	113	185	150	8-19	425	24	350	PHX-02K	PHR-02K	PDX-02K	0
100	102	229	123	210	175	8-19	467	31	540	PHX-02K	PHR-02K	PDX-02K	1
								38		PHX-06K	PHR-06K	PDX-06K	0

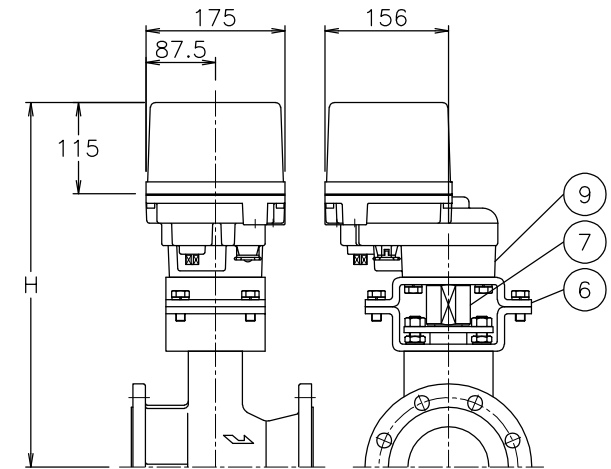

PHX (PHR, PDX) V-*01TUG-100

No	DESCRIPTION	MATERIALS	REQ'D	REMARKS
9	Actuator		1	
8	Joint	SCS13A	1	
7	Joint	SUSXM7/LAK52	1	100A(Sizing code 0)
		SUS304		065,080A
		SCS13A		100A(Sizing code 1)
				025~050A
6	Bracket	SCPH2/SS400	1	100A
		SCPH2		025~080A
5	Packing	N-PTFE	1set	
4	Stem	SUS316	1	
3	Seat	R-PTFE	1	
2	Ball	SCS11	1	HCrPLTD
1	Body	SCS13A	1	ND

NOTE
Actuator material: Aluminum alloy diecast cover.

ATTACHMENT
Cable gland (nylon), G 1/2, for 6φ to 12φ cable.
Plug.

MARK	DATE	BY	DATE	APPR'D	K.Y.	TITLE	J10K Flanged-end V type electric actuated control valve		
				CHK'D	K.Y.				
				DESIGN					
				DRAWN	P.O	MODEL	PHXV-**1TUG	PDXV-**1TUG	
						SCALE	NON	DWG No.	V-*1TUG-PXA15-EN
REVISIONS									
MV-3039									