



Please read this manual before installation and use.

GENERAL

It composed of wafer type butterfly damper and high-power electric actuator.
 (Proportional control)

Actuator

- AEX : For AC power.
- PEX : For AC / DC power.

Damper



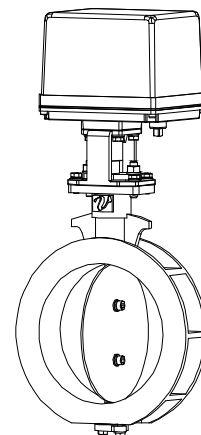



WT type With heat-resistant damper material this series can be used at fluid temperatures ranging from -40 °C to +550 (600) °C.





PRODUCT CODE

WT type (Without seat) (With SUS316 seat)	[] [] W T [] [] 2 T G 0 - [] [] [] - [] [] [] W T [] [] 2 T G S - [] [] [] - []	(1) (2) (3) (4) (5) (6) (7) (8) (9) (10) (11)	
(1) Actuator AEX PEX	(4) Sizing code 0 : Standard 1 : Light 2 : Heavy	(8) Seat material 0 : (Zero) None S : SUS316	(10) Option EA : Alarm output board EI : 4 to 20 mA Indication signal board L0 : Auxiliary limit switch L2 : Auxiliary limit switch XT : For high / low temperatures
(2) Damper WT	(5) Connection 2 : JIS 5K	(9) Size [mm] ex. 80 A → 080	(11) Operation mode Nil : Mode A J : Mode B
(3) Voltage 1 : 100 / 110 V AC 2 : 200 / 220 V AC 6 : 100 to 240 V AC 0 : 24 V DC	(6) Body material T : SCS13A	(7) Packing material G : Expansion graphite	(11) Input signal (AEX) It corresponds to various control input signals.

DAMPER SPECIFICATIONS

 Water
  Oil
  Air, Gas
  Steam
  Chemicals
  Sea water
  Slurry
  Negative pressure

Damper type		WT (Without seat)		WT (With SUS316 seat)
Design		2-way, Wafer		2-way, Wafer
Connection		JIS Flanges 5K		JIS Flanges 5K
Fluid				
Max pressure		20 kPa		20 kPa
Size [mm]		040 to 250	300 to 400	040 to 400
Material	Body	SCS13A		SCS13A
	Disc	SUS420J2	SUS420J1	SUS410S / SUS420J2
	Seat	None		SUS316
Stem seal	Packing	Expansion graphite		Expansion graphite

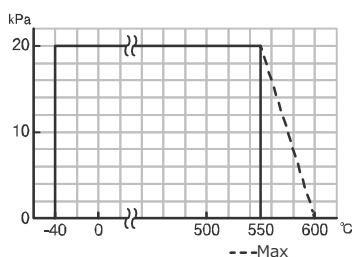
PRESSURE & TEMPERATURE RATING

Temperature range : -40 to 600 °C

Note) If the fluid temperature is more than +250 °C or less than -20 °C, the option (XT) is required.

SEAT LEAKAGE VOLUME

	Damper size [mm]	Remarks
WT-2TG0 (Without seat)	040 to 050	Less than 2 % of rated Cv.
	065 to 400	Less than 1 % of rated Cv.
WT-2TGS (With SUS316 seat)	040	Less than 1 % of rated Cv.
	050	Less than 0.5 % of rated Cv.
	065	Less than 0.2 % of rated Cv.
	080 to 400	Less than 0.1 % of rated Cv.

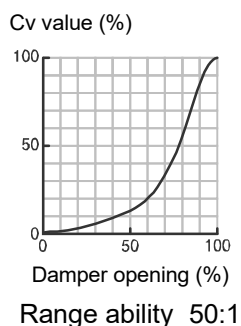
INHERENT FLOW CHARACTERISTIC

ELECTRIC ACTUATOR SPECIFICATIONS

AEX type

Actuator type (□:Voltage code)	AEX-120-□	AEX-360-□	AEX-700-□	AEX-02K-□	AEX-06K-□
Voltage	100 / 110 AC V \pm 10 % 50/60 Hz (Code: 1) 200 / 220 AC V \pm 10 % 50/60 Hz (Code: 2)				
Rated torque [N·m]	12	36	70	200	600
Operation time [s]	30 / 25 (50/60 Hz)	36 / 30 (50/60 Hz)	72 / 60 (50/60 Hz)	77 / 64 (50/60 Hz)	77 / 64 (50/60 Hz)
Power consumption [VA]	9.5	13		45	220
Motor	Synchronous motor (Triac control)			Reversible motor (Triac control)	
Overload protection	Timer				
Method of operation	Proportional control				
Input signal	4 to 20 mA / 1 to 5 V (Input resistance: 250 Ω) (Standard) 0 to 5 V / 0 to 10 V / 2 to 10 V (Input resistance: more than 1 M Ω) 0-135 Ω to 0-1 k Ω Potentiometer input (Applied voltage: 5 V DC)				
Operation *1	[Mode A] SHUT by decreased signal (Standard) OPEN by increased signal [Mode B] SHUT by increased signal OPEN by decreased signal [Forced open / shut] It takes priority over the input signal. C-S is ON \rightarrow SHUT. (Common in mode A / B) C-O is ON \rightarrow OPEN.				
Indication signal	0 mA : SHUT \leftrightarrow 1 mA : OPEN (External load resistance: less than 3 k Ω) Common in mode A / B				
Override switch	It takes priority over the input signal. Common in mode A / B Dry contact / Transistor, Open collector. (Input signal current: 6 mA 15V DC)				
Operating range	SHUT: 0 to 40% OPEN: 50 to 100%				
Resolution	Less than 0.2%				
Duty cycle	100 %				
Ambient temperature	-20 to 55°C				
Space heater	2 W				
Manual operation	Manual shaft				
Enclosure	Equivalent to IP65 (IEC 60529)				
Housing material	Aluminum alloy die cast (acrylic resin baking finish)				
Wire connection	Terminal Block: M3, Ground terminal: M3				
Conduct port	2-G1/2 Attachments: Cable gland (for Φ 6 to 12 mm cable), plug.				

*1 Change by DIP switch. (Standard \rightarrow Potentiometer input or 0 to 5 V / 0 to 10 V / 2 to 10 V)*2 Change by DIP switch. (Standard \rightarrow Mode B)

ELECTRIC ACTUATOR SPECIFICATIONS

WIRING

AEX

Setting with DIP SW

- Operation

Mode A	Mode B
ON OFF	ON OFF
4	4
3	3
2	2
1	1
- Input signal

ON OFF
4
3
2
1

4 to 20 mA / 1 to 5 V

0-135 Ω to 0-1 kΩ Potentiometer input / 0 to 5 V

ON OFF
4
3
2
1

0 to 10 V

ON OFF
4
3
2
1

2 to 10 V

Note

- Input signal circuit is non-isolated. Do not connect DC (minus) wire to other DC (minus) common.
- Do not adjust the "O-L" and "S-L" trimmer. It is adjusted at the factory.

ADJUSTMENT OF ACTUATOR

AEX

- ① **Dead band**
Turn the trimmer clockwise for wide the dead band as necessary. It is useful to prevent the hunting reaction of actuator. *Each trimmer on a built-in control board.
- ② **Operating range**
Turn clockwise and adjust valve / damper to open side.
 - Adjust the closed position by SHUT trimmer.
 - Adjust the open position by OPEN trimmer.

ELECTRIC ACTUATOR SPECIFICATIONS

PEX type

Actuator type (□:Voltage code)	PEX-120-□	PEX-300-□	PEX-700-□
Voltage	100 to 240 V AC $\pm 10\%$ 50/60 Hz (Code: 6) 24 V DC +20 % ~ -10 % (Code: 0) Cannot use a half or full-wave DC power supply.		
Rated torque [N·m]	10	21	50
Operation time [s]	2.5 to 4 (Max 12)	6 to 9 (Max 34)	12 to 18 (Max 68)
	The operation time is the time when it is operated by the override switch. Operation time with the override switch cannot be adjusted with S.C. trimmer. At factory shipment, the S.C trimmer is set to the fastest position.		
Power consumption [VA]	AC power 80 DC power 50		
Motor	Brushless DC motor (PWM Control)		
Overload protection	Current limiter		
Method of operation	Proportional control		
Input signal	4 to 20 mA / 1 to 5 V (Input resistance: 250 Ω)		
Operation *1	[Mode A] SHUT by decreased signal (Standard) OPEN by increased signal [Mode B] SHUT by increased signal (Option: J) OPEN by decreased signal [Forced open / shut] It takes priority over the input signal. C-S is ON \rightarrow SHUT. (Common in mode A / B) C-O is ON \rightarrow OPEN.		
Indication signal	0 mA : SHUT \leftrightarrow 1 mA : OPEN (External load resistance: less than 3 k Ω) Common in mode A / B		
Override switch	It takes priority over the input signal. Common in mode A / B Dry contact / Transistor, Open collector. (Input signal current: 6 mA 15V DC)		
Operating range	SHUT: 0 to 40 % OPEN: 50 to 100 %		
Resolution	Less than 0.2 %		
Duty cycle	100 %		
Ambient temperature	-20 to 55 $^{\circ}$ C		
Space heater	3 W		
Manual operation	Manual shaft		
Enclosure	Equivalent to IP65 (IEC 60529)		
Housing material	Aluminum alloy die cast (acrylic resin baking finish)		
Wire connection	Terminal Block: M3, Ground terminal: M3		
Conduct port	2-G1/2 Attachments: Cable gland (for $\Phi 6$ to 12 mm cable), plug.		

*1 Change by DIP switch. (Standard \rightarrow Mode B)

ELECTRIC ACTUATOR SPECIFICATIONS

WIRING

PEX

Setting with DIP SW

- Operation

Mode A (Standard)	Mode B

Note

- Do not adjust the "O-L" and "S-L" trimmer. It is adjusted at the factory.
- Minus terminal can be used in common, but T2 terminal for DC power supply is not a common terminal.

ADJUSTMENT OF ACTUATOR

PEX

- ① **Dead band**
Turn the trimmer clockwise for wide the dead band as necessary. It is useful to prevent the hunting reaction of actuator. *Each trimmer on a built-in control board.
- ② **Operating range**
Turn clockwise and adjust valve/damper to open side.
 - Adjust the closed position by SHUT trimmer.
 - Adjust the open position by OPEN trimmer.
- ③ **Operating speed (Speed control)**
Slow by turn the S.C. trimmer counterclockwise.
Fast by turn the S.C. trimmer clockwise.

Note) The operation time is the time when it is operated by the override switch.
Operation time with the override switch cannot be adjusted with S.C. trimmer.
At factory shipment, the S.C trimmer is set to the fastest position.

ELECTRIC ACTUATOR SPECIFICATIONS

OPTIONAL PARTS

Specifications	Code No.	AEX	PEX	Remarks	
Input signal and operation	4 to 20 mA or 1 to 5 V	Nil	○	○	Mode A (Standard)
		J	○	○	Mode B
	0-135 Ω to 0-1 kΩ Potentiometer input or 0 to 5 V	F	○		Mode A
		K	○		Mode B
	0 to 10 V	G	○		Mode A
		N	○		Mode B
	2 to 10 V	H	○		Mode A
M		○		Mode B	
Auxiliary limit switch (Select limit switch depending on the load)	L0	○	○	For standard signal	
	L2	○	○	For micro load signal	
Alarm output board	EA	○	○	EI and EA cannot be used together.	
4 to 20 mA Indication signal board	EI	○	○		

*Auxiliary limit switch: Please refer to the specifications.

WIRING (OPTION)

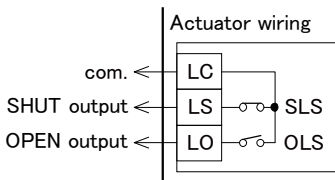
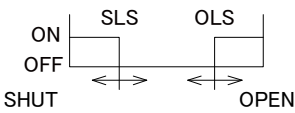
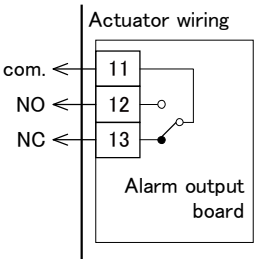
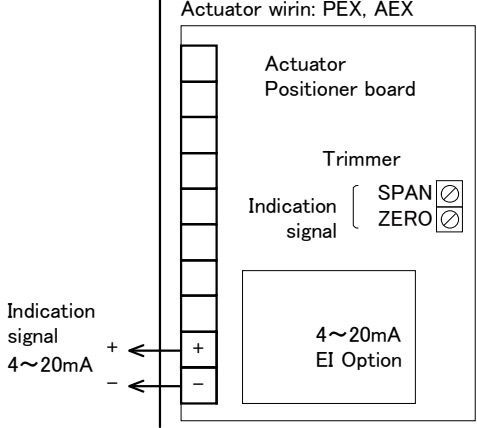
L0, L2	Auxiliary limit switch	EA	Alarm output board	EI	4 to 20 mA Indication signal board
	 <p>At CLOSE side, LC and LS is ON. At OPEN side, LC and LO is ON.</p>  <p>ON point can be reset by adjusting the cam.</p>	 <p>NO : Normally open NC : Normally closed</p> <p>Alarm SW will be ON, when overload protector works.</p> <p>Error → 11 and 12 is ON. Normal → 11 and 13 is ON.</p> <p>Cannot be used with EI option.</p>	 <p>EI option board output an isolated indication signal from the plus and minus terminal with 4 to 20 mA by AEX / PEX positioner board.</p>		

ELECTRIC ACTUATOR SPECIFICATIONS

DIMENSIONS

AEX

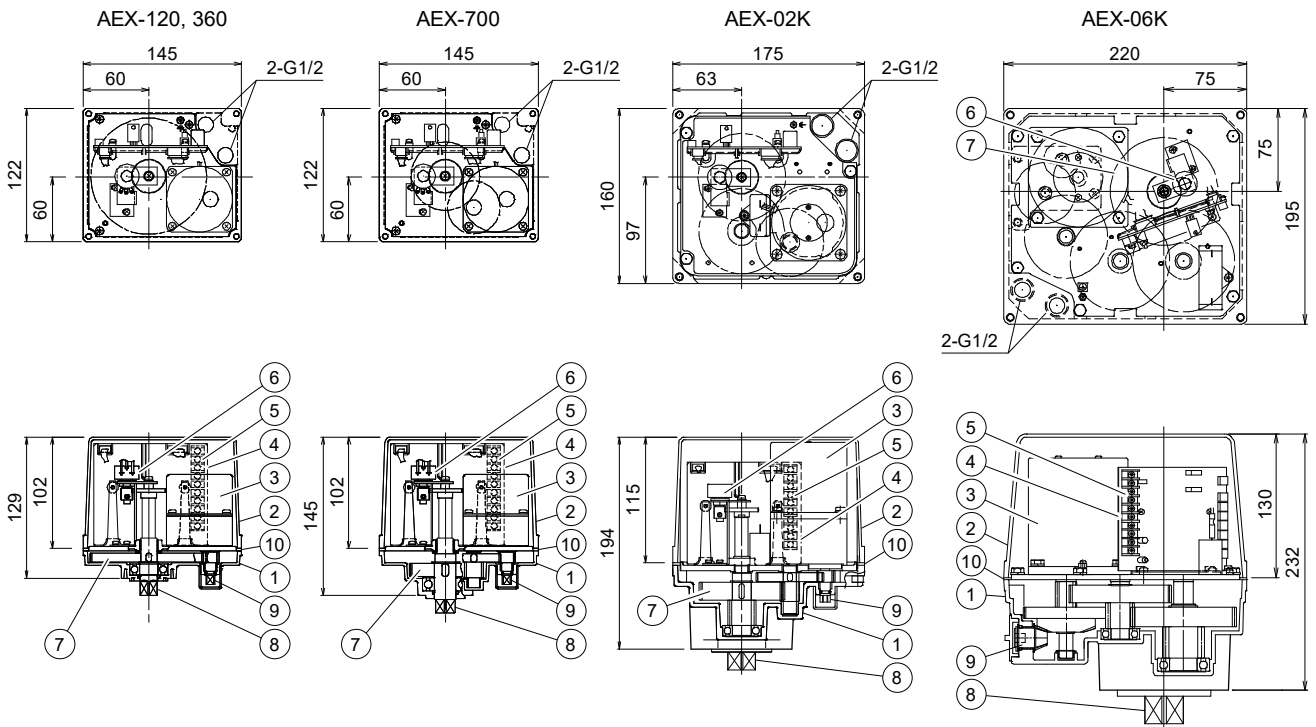

PEX

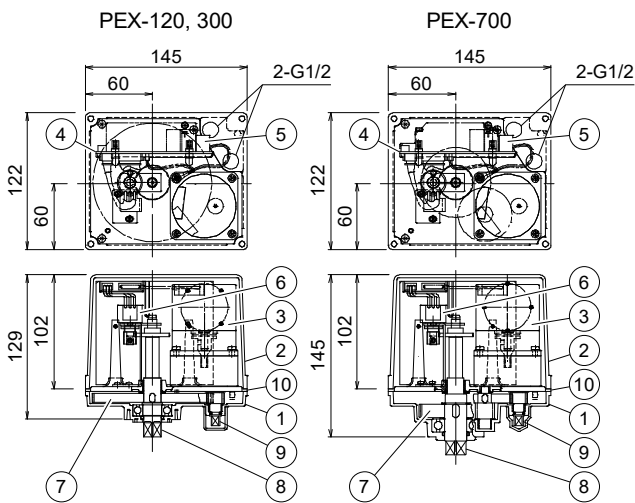

Parts name

1	Body	4	Control board	7	Drive gear	10	Rubber packing
2	Motor cover	5	Terminal block	8	Drive shaft		
3	Motor	6	Potentiometer	9	Manual shaft		

INSTALLATION, OPERATION & MAINTENANCE INSTRUCTIONS

HANDLING & STORAGE

①HANDLING

Do not drop or throw the product as it may break.

②STORAGE

- Store away from dust, moisture and direct sunlight. If possible, store in the original package.
- Do not remove a dust proof cap until the piping.

③CHECKING

- Check the product code, power supply, and voltage before installation.
- Make sure that the bolts are not loose.
- The DIP switch should be set up before the power is turned on. Do not touch unnecessary switches.

INSTALLATION

①PRECAUTIONS

- Flush the pipeline carefully before installing the damper. Foreign particles, such as sand or pieces of welding electrode, will damage the disk and seats.
- For dampers with specified flow direction (WT), check the arrows on the product before piping.
- Damper is shipped closed. (allows quick piping.)
- The butterfly damper should be piped upstream of the elbow. When piping downstream from the elbow, considered a straight line that is at least five times the length of the pipe.

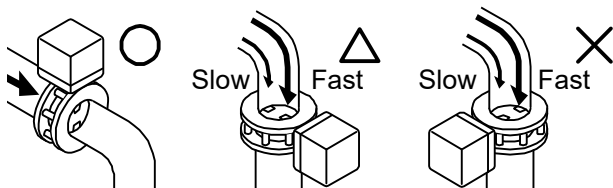

- The damper stem should be mounted perpendicular to the flow for biased fluid.
- Disc interference may also occur when damper is installed in pipeline with smaller than normal inside diameter such as thick wall pipe, or lining pipe. Suitable corrective measurement must be taken (taper boring the pipe or pipe liner, etc.)

②PIPING FLANGES

- Gasket should be selected appropriately to suit the fluid, pressure and temperature. Use spring washer to prevent from decreasing surface pressure gasket when the temperature change happens frequently.
- Wafer type butterfly damper is put between two seats of flanged-end and tightened with long bolts.
- Before bolts are tightened, damper should be centered within the bolts to prevent possible disc interference or damage by contact with the pipe or flange.
- Tighten all bolts using crossover method to load the joint evenly.

③ENVIRONMENT

- Do not install in place where corrosive gas is present or where vibration is heavy (0.5 G or more).
- When radiant heat causes the surface temperature of the control unit to exceed 55°C, provide an appropriate shielding plate.
- If there is a possibility that the fluid and drive part freeze, please take measures to prevent freezing.

④POSITIONING

Should be positioned through 90° upward from horizontal. Provide space around the product to allow manual operation, inspection and replacement work.

Maintenance space for upper part of actuator.

AEX (120 / 360 / 700)	PEX	More than 105 mm
AEX (02K / 06K)		More than 120 mm

⑤CAUTION AFTER PIPING

Until the wiring is completed there must be no condensation or flooding in the interior of the actuator, after piping. Protective caps on the cable gland are not waterproof.

⑥INSULATION WORK

- For maintenance of gland packing, insulation should be below the ground part.
- The upper part of the ground plate part is a heat dissipation part, do not insulate it.

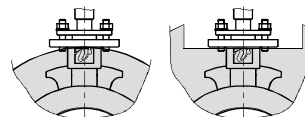

TIGHTEN THE GLAND NUTS

- Check that there is no leakage from the gland packing.
- If it leakage, tighten gland nuts by alternately. Do not over-tighten the gland nuts.

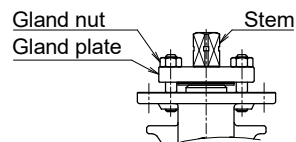

Damper size [mm]	Recommended torques [N·m]
040 050 065	1
080 100 125	2
150 200 250 300	5
350 400	8

INSTALLATION, OPERATION & MAINTENANCE INSTRUCTIONS**WIRING****①PRECAUTIONS**

- Remove the actuator cover before wiring.
- Two G1/2 electrical connections are provided with a cable gland and plug. Usable cable size is $\Phi 6$ to 12 mm.
- When using a flexible tube, dew condensation may occur inside the actuator due to respiration from the inside of the tube and malfunction may result. Seal the flexible tube connector part with a sealant.
- Sealants that affect the electrical contacts should not be used inside the electric actuator.
- If long distance wiring or low voltage operation, check that terminal voltage is in the proper range.
- AEX type input signal circuit is non-isolated. Do not connect DC (minus) wire to other DC (minus) common.
- PEX type minus terminal can be used in common, but T2 terminal for DC power supply is not a common terminal.

②CONNECTION

- Do not wiring outdoors on a rainy day.
- Check the power supply and voltage. Connect the signal as shown in the wiring diagram. Do not connect unnecessarily terminal.
- Check whether the MODE change DIP SW on a circuit board substrate is set up correctly.
- When wiring, if wiring of a signal is mistaken, it will not operate correctly. Contact us when you use two damper or more by one controller or indicator.
- Actuator should be electrically grounded. Use the terminal marked (\oplus) inside the actuator.

PREVENT DEW CONDENSATION

- When installing the cover after wiring, perform the bolt by the temporary tightening procedure and the permanent tightening procedure to tightly and securely tighten the rubber packing so that water does not enter from the outside.
- Tighten the cable gland nut so that there is no leakage from the wire entrance.

CONTROL**①INPUT SIGNAL**

- Use shielded wire for signal wiring where high level noise is generated or when the wiring distance is long.
- Control with a 1 to 5 V input signal becomes an input resistance 250 Ω . Provide a voltage that can safely 20mA or more than.

②DC POWER SUPPLY

- Cannot use a half or full-wave power supply.
- Consider an inrush current of motor. (It is 1.5 to 3 times of consumed current.)
- When using a DC voltage, be selected the wire thickness by the wiring distance.
- Do not use power supply that require more than 1 second with rise and fall time.

③INPUT SIGNAL AND OPERATION MODE

The input signal and operation mode are set as follows. (Factory shipped)

Input signal	4 to 20 mA or 1 to 5 V
Operation mode	Mode A
Operation	SHUT by decreased signal. OPEN by increased signal.

OPERATION**①TESTING**

- Make sure that power supply voltage is correct. Also check operating position, wiring, speed and signals.
- During trial operation, check that damper movement and output signal are correct.

②CONFIRM THE OPERATING CONDITION

- Adjust fluid condition, controller setting, sensor etc. so that stable control is achieved.
- When used in an unstable control state, the life of the actuator and the damper will be shortened.
- The desired control state is stable at the target value. Adjust the PID setting value of the controller when overshooting the target value greatly, when not converging for a long time or hunting operation. Also, when the time delay is large, please consider the sensor position.

③ATTENTION

- Do not change an unnecessary dip switch.
- Keep power supplied for built-in space heater to prevent condensation inside actuator.
- Do not touch the moving parts of actuator in operation.
- Never put anything on the actuator or make it into a foothold.

INSTALLATION, OPERATION & MAINTENANCE INSTRUCTIONS**MANUAL OPERATION****①PRECAUTIONS**

- Be sure to turn off the power before manual operation.
- Operate manually with reference to the opening degree label. Do not turn beyond the fully open / fully closed position. Operation failure may occur during automatic operation.

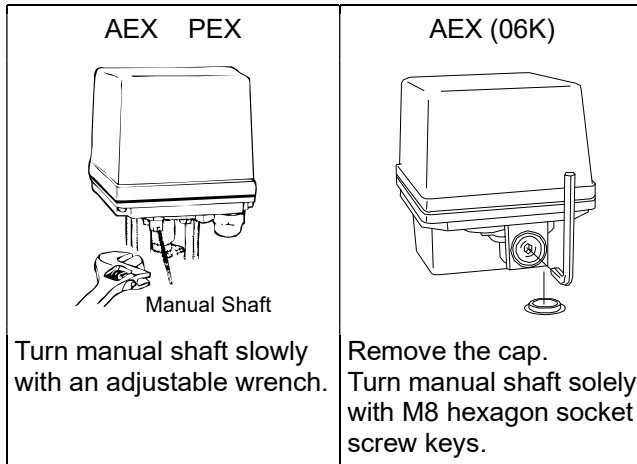
②THE WAY OF OPERATION

Before automatic operation, be sure to remove the wrench.

MAINTENANCE

- To prevent electric shock, be sure to turn off the power when removing the actuator cover.
- Do the routine maintenance at least once in half a year.

Inspection items

- Confirm operation of opening and closing.
- Confirm that an actuator is not hot excessively.
- Confirm existence of abnormal noise and vibration during operation.
- Confirm whether screws are loose or not.
- Confirm that water or condensation no remains in the actuator.
- Confirm the fluid temperature or pressure.
- Confirm the leak from damper stem.
- Confirm the bolt tightening torque.

INSTALLATION, OPERATION & MAINTENANCE INSTRUCTIONS**TROUBLE SHOOTING**

Problem	Cause	Solution
Actuator does not move.	Faulty wiring.	Correct the wiring.
	Voltage and input signal are not coming.	Check the voltage and input signal.
	Incorrect voltage.	When it's burned out by excess voltage, replace the actuator.
	Connection or wiring is not correct.	Correct the miswiring and misconnection. Be careful not to mistake the plus and minus of wiring.
	Short the circuit, contact failure.	Review wires and connection.
	Motor is too old.	Replace the actuator. Repair in our factory.
Operation is unstable.	Excess surge or voltage was applied.	<ul style="list-style-type: none"> • Replace the control board or limit switch. (Repair in our factory) • Replace the actuator.
	Rainwater entered the actuator.	<ul style="list-style-type: none"> • Dry the inside. • Replace the actuator.
	Added high harmonics noise from an inverter.	Attachment a filter for each inverter maker option.
	Effect of high level noise.	Use the shielded wire and ground the wiring. Separate signal wire from power line.

Problem	Cause	Solution
Stop in the mid position. (Input signal 1 to 5 V)	Signal voltage source capacity shortage.	Use a voltage source that can be made to flow more than 20 mA. Please contact us.
Stop in the mid position.	There is a foreign object in the damper.	Remove a foreign object.
	Damper is distorted.	Replace the damper.
	Overload protector runs because of over-torque.	Motor protection circuit returns by the signal of operation of an opposite direction. Turn on the power again.
Alarm LED is lit.		
Leakage from damper gland	Gland packing is worn or distorted.	Tighten the gland nut.
		Replace the gland packing.

For more information contact
NIPPON VALVE CONTROLS, INC. for consultation.