



Please read this manual before installation and use.

GENERAL

It composed of flange-end ball valve and high-power electric actuator.
(proportional control)

Actuator

- PDX : For AC / DC power.
- PHX : For AC / DC power.

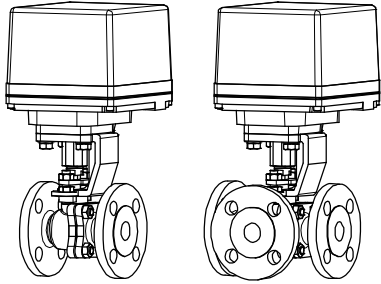

Valve

- BF type For various fluids and general use.
- V type For control
- L2 type For mixing / dividing.

PRODUCT CODE

BF type	(JIS 10K)	<input type="text"/>	B	F	<input type="text"/>	<input type="text"/>	1	<input type="text"/>	<input type="text"/>	-	<input type="text"/>	-	<input type="text"/>	-	<input type="text"/>
	(JIS 20K)	<input type="text"/>	B	F	<input type="text"/>	<input type="text"/>	3	T	T	<input type="text"/>	-	<input type="text"/>	-	<input type="text"/>	-
V type	(JIS 10K)	<input type="text"/>	V	-	<input type="text"/>	<input type="text"/>	1	<input type="text"/>	U	<input type="text"/>	-	<input type="text"/>	-	<input type="text"/>	-
	(JIS 20K)	<input type="text"/>	V	-	<input type="text"/>	<input type="text"/>	3	<input type="text"/>	U	<input type="text"/>	-	<input type="text"/>	-	<input type="text"/>	-
L2 type		<input type="text"/>	L	2	<input type="text"/>	<input type="text"/>	1	<input type="text"/>	<input type="text"/>	G	-	<input type="text"/>	-	<input type="text"/>	-
		(1)	(2)	(3)	(4)	(5)	(6)	(7)	(8)		(9)		(10)		(11)

(1) Actuator PDX PHX	(6) Body material D : FCD400 / FCD-S T : SCS13A / SCS13 U : SCS14A / SCS14 W : SCS16A	(10) Option EA : Alarm output board EI : 4 to 20 mA Indication signal board L0 : Auxiliary limit switch L2 : Auxiliary limit switch
(2) Valve BF V- L2	(7) Ball material T : SCS13A / SUS304 U : SCS14A / SUS316 / SCS11 W : SCS16A / SUS316L	(11) Operation mode Nil : Mode A J : Mode B
(3) Voltage 1 : 100 / 110 V AC 2 : 200 / 220 V AC 0 : 24 V DC 3 : 24 V AC	(8) Seat material T : N-PTFE G : R-PTFE R : R-PTFE (with metal-ring) S : Thin seat M : Solid seat	(11) Input signal (PDX) It corresponds to various control input signals.
(4) Sizing code 0 : Standard 1 : Light 2 : Heavy	(9) Size [mm] ex. 25 A → 025	
(5) Connection 1 : JIS 10K 3 : JIS 20K		

VALVES SPECIFICATIONS

Water
 Oil
 Air, Gas
 Steam
 Chemicals
 Sea water
 Slurry
 Negative pressure

BF type





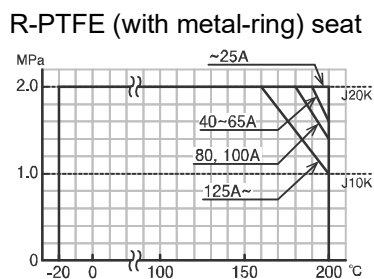
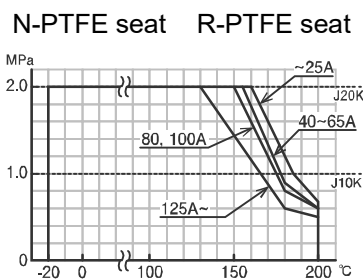

Valve type	BF						
Design	2-way, Full port						
Connection	JIS10K Flanged-end			JIS20K Flanged-end			
Fluid							
Max pressure	1 MPa			2 MPa			
Size [mm]	015 to 150			015 to 150			
Material	Body	FCD400	SCS13A	SCS14A	SCS16A	SCS13A	
	Ball	SCS13A / SUS304		SCS14A / SUS316		SCS16A / SUS316L	SCS13A / SUS304
	Seat	N-PTFE R-PTFE R-PTFE (with metal-ring)					
Stem seal	Packing	N-PTFE					

PRESSURE & TEMPERATURE RATING









Note) Insulation options are required for use with fluids more than 150 °C.

VALVES SPECIFICATIONS

 Water
  Oil
  Air, Gas
  Steam
  Chemicals
  Sea water
  Slurry
  Negative pressure

V type

Valve type	V					
Design	2-way, V-port					
Connection	JIS10K Flanged-end			JIS20K Flanged-end		
Fluid	     					
Max pressure	1 MPa			2 MPa		
Size [mm]	025 to 200					
Material	Body	FCD-S SCS13A SCS14A			SCS13A SCS14A	
	Ball	SCS11 + HCr plated		SCS11 + Stellite	SCS11 + HCr plated	SCS11 + Stellite
	Seat	R-PTFE	Thin seat	Solid seat	R-PTFE	Thin seat
Stem seal	Packing	PTFE				

PRESSURE & TEMPERATURE RATING

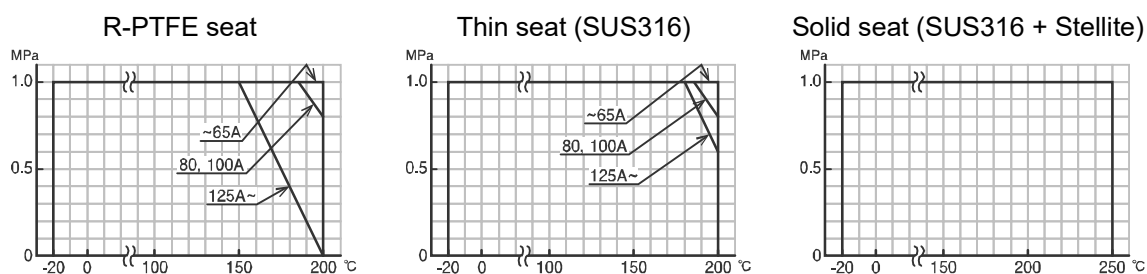

Note) Insulation options are required for use with fluids more than 150 °C.

SEAT LEAKAGE VOLUME

	Seat material	Leakage rate	Remarks
M	Solid seat	Less than 0.5% of rated Cv.	ANSI B16.104 Class II (IEC 534-4 Class II)
S	Thin seat	Less than 0.0005% of rated Cv.	1/20 of ANSI B16.104 Class IV (IEC 534-4 Class IV-S1)
G	R-PTFE	Bubble-tight	

INHERENT FLOW CHARACTERISTIC

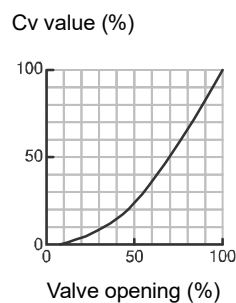

Range ability 100:1





APPLICATION OF THE VALVE WITH METAL SEAT

	Seat material	Use
M	Solid seat	Slurry Powder High-viscous and High temperature fluid
S	Thin seat	Pulp Viscous fluid Sludge

VALVES SPECIFICATIONS

 Water
  Oil
  Air, Gas
  Steam
  Chemicals
  Sea water
  Slurry
  Negative pressure

L2 type

Valve type		L2		
Design		3-way, Full port		
Connection		JIS10K Flanged-end		
Fluid		    		
Max pressure		1 MPa		
Size [mm]		020 to 100		
Material	Body	FCD400	SCS13A	SCS14A
	Ball	SCS13A / SUS304		SCS14A / SUS316
	Seat	R-PTFE (Proportional control: seat code G only)		
Stem seal	Packing	N-PTFE		

PRESSURE & TEMPERATURE RATING

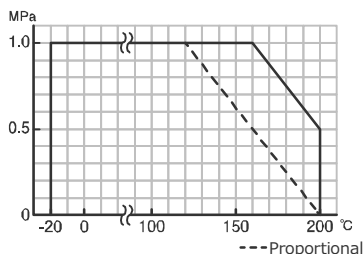

Note) Insulation options are required for use with fluids more than 150 °C.

INHERENT FLOW CHARACTERISTIC

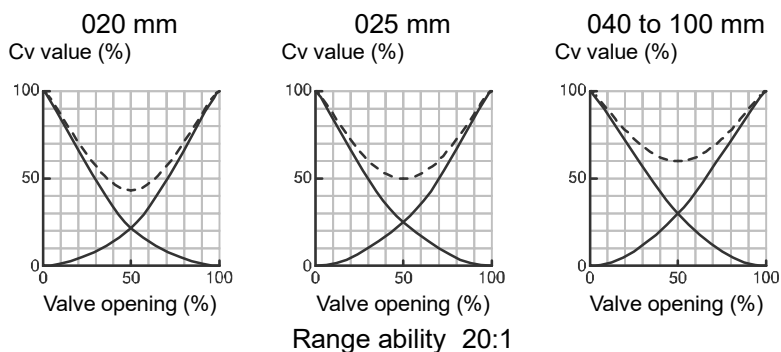

FLOW PATHS (Position① / P1) (Position② / P2)

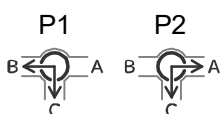

Note) When a closed path is exposed to high pressure, it may leak slightly to an open path.

ELECTRIC ACTUATOR SPECIFICATIONS

3 way valve: SHUT / Position①, OPEN / Position②

PDX type

Actuator type (□:Voltage code)	PDX-300-□	PDX-700-□	PDX-02K-□	PDX-06K-□
Voltage	100 / 110 V AC ±10 % 50/60 Hz (Code: 1) 200 / 220 V AC ±10 % 50/60 Hz (Code: 2) 24 V AC ±10 % 50/60 Hz (Code: 3) 24 V DC (Code: 0)			
Rated torque [N·m]	21	50	140	400
Operation time [s]	6 to 20, Variable	15 to 50, Variable	30 to 100, Variable	90 to 300, Variable
Power consumption (Max) [VA]	AC power 100 DC power 80		AC power 150 DC power 120	
Motor	DC motor (VIC: voltage, current control)			
Overload protection	Current limiter			
Method of operation	Proportional control			
Input signal	4 to 20 mA 1 to 5 V (Input resistance: 250 Ω) (Standard) 0 to 5 V 0 to 10 V 2 to 10 V (Input resistance: more than 1 M Ω) 0-135 Ω to 0-1 kΩ Potentiometer input (Applied voltage: 5 V DC)			
Operation *1	[Mode A] SHUT by decreased signal ↔ OPEN by increased signal [Mode B] SHUT by increased signal ↔ OPEN by decreased signal [Forced open / shut] It takes priority over the input signal. C-S is ON → SHUT C-O is ON → OPEN Common in mode A / B			
Indication signal	0 mA : SHUT ↔ 1 mA : OPEN (External load resistance: less than 3 kΩ) Common in mode A / B			
Override switch	It takes priority over the input signal. Common in mode A / B Dry contact / Transistor, Open collector. (Input signal current: 6 mA 15V DC)			
Operating range	SHUT: 0 to 40% OPEN: 50 to 100%			
Resolution	Less than 0.5 %	Less than 0.2 %		
Duty cycle	50% 30 min.			
Ambient temperature	-20 to 55 °C			
Space heater	3 W			
Manual operation	Manual over-ride with clutch. (Direct operation / 06K: Operation by manual shaft.)			
Enclosure	Equivalent to IP65 (IEC 60529)			
Housing material	Aluminum alloy die cast (acrylic resin baking finish)			
Wire connection	Terminal Block: M3, Ground terminal: M3			
Conduct port	2-G1/2 Attachments: Cable gland (for Φ6 to 12 mm cable), plug.			

*1 Change by DIP switch. (Standard → Potentiometer input or 0 to 5 V 0 to 10 V 2 to 10 V)

*2 Change by DIP switch. (Standard → Mode B)

ELECTRIC ACTUATOR SPECIFICATIONS

3 way valve: SHUT / Position①, OPEN / Position②

WIRING

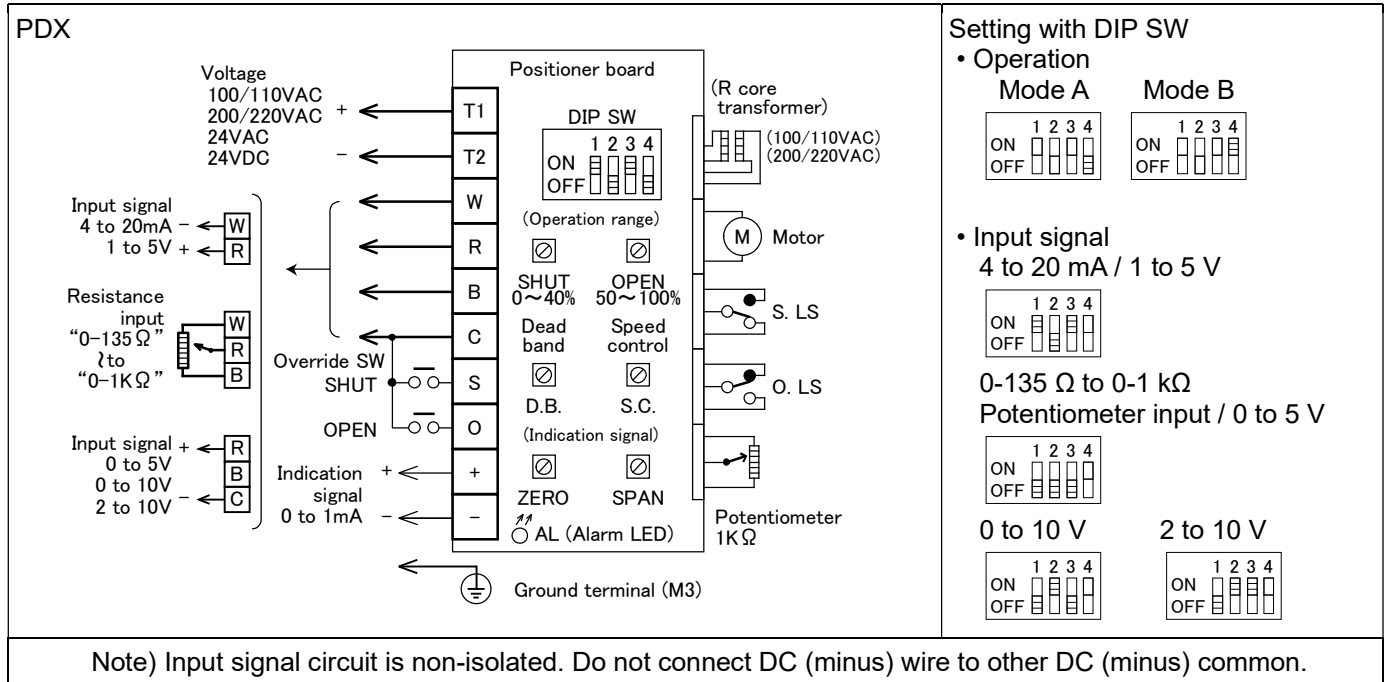

ADJUSTMENT OF ACTUATOR

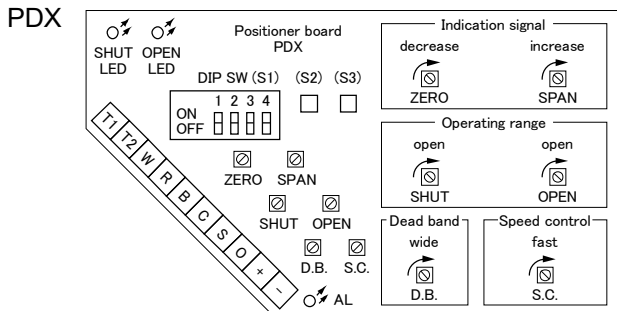

- ① Dead band
Turn the trimmer clockwise for wide the dead band as necessary. It is useful to prevent the hunting reaction of actuator. *Each trimmer on a built-in control board.
- ② Operating range
Turn clockwise and adjust valve/damper to open side.
 - Adjust the closed position by SHUT trimmer.
 - Adjust the open position by OPEN trimmer.
- ③ Operating speed (Speed control)
Slow by turn the S.C. trimmer counterclockwise.
Fast by turn the S.C. trimmer clockwise.

At factory shipment, the S.C trimmer is set to the mid position. Operation time with the override switch cannot be adjusted with S.C. trimmer.

ELECTRIC ACTUATOR SPECIFICATIONS

3 way valve: SHUT / Position①, OPEN / Position②

PHX type

Actuator type (□:Voltage code)	PHX-300-□	PHX-700-□	PHX-02K-□	PHX-06K-□
Voltage	100 / 110 V AC ±10 % 200 / 220 V AC ±10 % 24 V AC ±10 % 24 V DC	50/60 Hz (Code: 1) 50/60 Hz (Code: 2) 50/60 Hz (Code: 3) (Code: 0)		
Rated torque [N·m]	21	50	140	400
Operation time [s]	AC: 1.2 to 2.5 DC: 2 to 2.5 (Max 8)	AC: 3.5 to 7 DC: 4.5 to 7 (Max 22)	AC: 11 to 23 DC: 15 to 23 (Max 78)	AC: 35 to 70 DC: 45 to 70 (Max 230)
	The operation time is the time when it is operated by the override switch. Operation time with the override switch cannot be adjusted with S.C. trimmer. At factory shipment, the S.C trimmer is set to the fastest position.			
Power consumption (Max) [VA]	120			
Motor	Brushless DC motor (PWM Control)			
Overload protection	Current limiter			
Method of operation	Proportional control			
Input signal	4 to 20 mA / 1 to 5 V (Input resistance: 250 Ω)			
Operation *1	[Mode A] SHUT by decreased signal ↔ OPEN by increased signal (Standard) [Mode B] SHUT by increased signal ↔ OPEN by decreased signal (Option: J) [Forced open / shut] It takes priority over the input signal. C-S is ON → SHUT C-O is ON → OPEN Common in mode A / B			
Indication signal	0 mA : SHUT ↔ 1 mA : OPEN (External load resistance: less than 3 kΩ) Common in mode A / B			
Override switch	It takes priority over the input signal. Common in mode A / B Dry contact / Transistor, Open collector. (Input signal current: 6 mA 15V DC)			
Operating range	SHUT: 0 to 40 % OPEN: 50 to 100 %			
Resolution	Less than 0.2 %			
Duty cycle	100 %			
Ambient temperature	-20 to 55 °C			
Space heater	3 W			
Manual operation	Manual over-ride with clutch. (Direct operation / 06K: Operation by manual shaft.)			
Enclosure	Equivalent to IP65 (IEC 60529)			
Housing material	Aluminum alloy die cast (acrylic resin baking finish)			
Wire connection	Terminal Block: M3, Ground terminal: M3			
Conduct port	2-G1/2 Attachments: Cable gland (for Φ6 to 12 mm cable), plug.			

*1 Change by DIP switch. (Standard → Mode B)

ELECTRIC ACTUATOR SPECIFICATIONS

3 way valve: SHUT / Position①, OPEN / Position②

WIRING

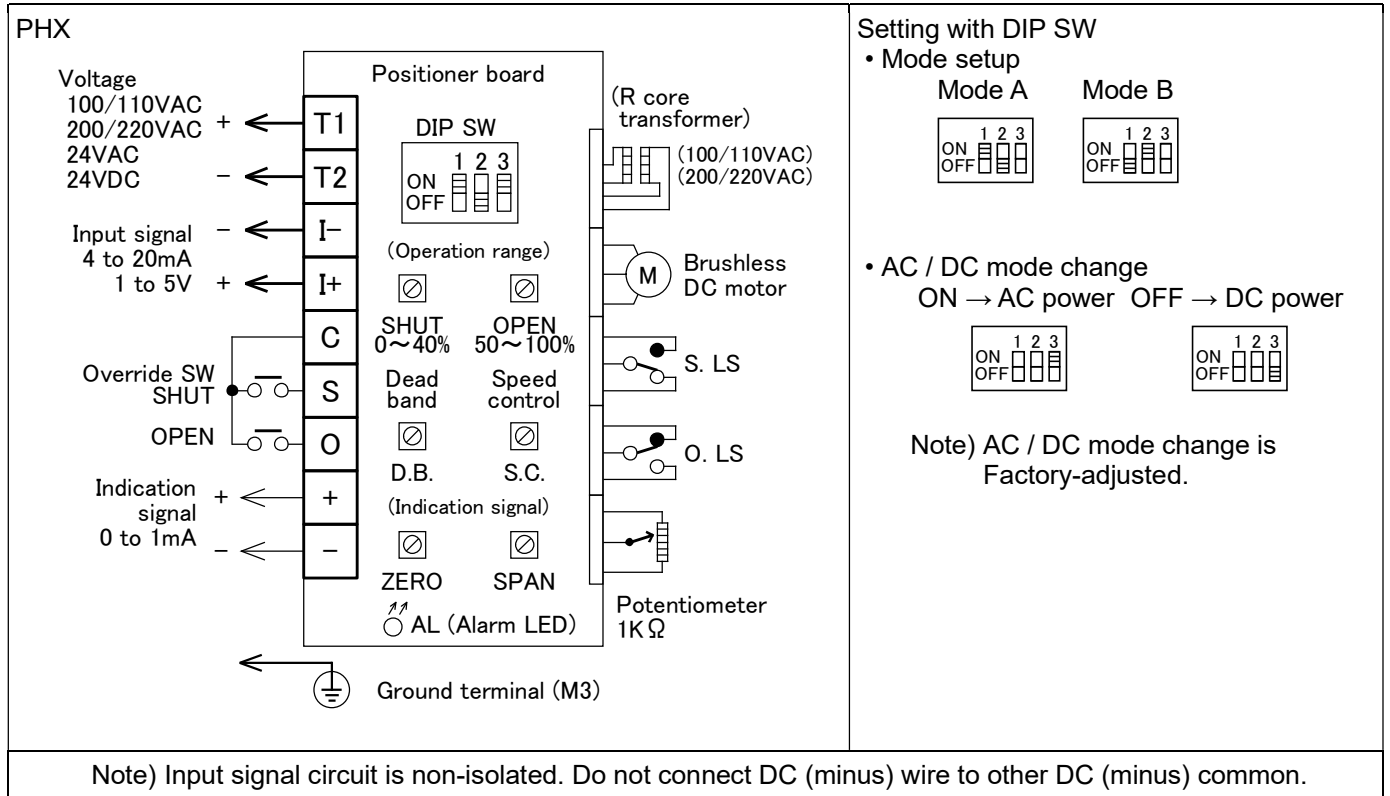

ADJUSTMENT OF ACTUATOR

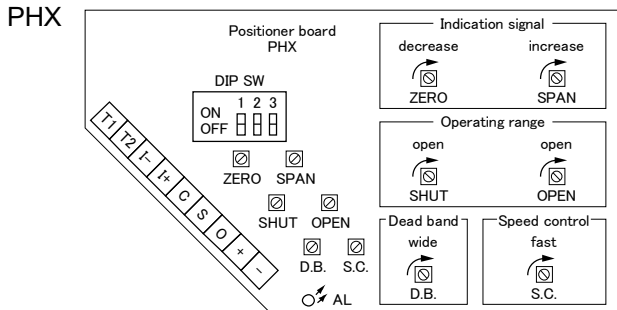

- ① **Dead band**
Turn the trimmer clockwise for wide the dead band as necessary. It is useful to prevent the hunting reaction of actuator. *Each trimmer on a built-in control board.
- ② **Operating range**
Turn clockwise and adjust valve/damper to open side.
 - Adjust the closed position by SHUT trimmer.
 - Adjust the open position by OPEN trimmer.
- ③ **Operating speed (Speed control)**
Slow by turn the S.C. trimmer counterclockwise.
Fast by turn the S.C. trimmer clockwise.

Note) The operation time is the time when it is operated by the override switch.
Operation time with the override switch cannot be adjusted with S.C. trimmer.
At factory shipment, the S.C trimmer is set to the fastest position.

ELECTRIC ACTUATOR SPECIFICATIONS

3 way valve: SHUT / Position①, OPEN / Position②

OPTIONAL PARTS

Specifications	Code No.	PDX	PHX	Remarks	
Input signal and operation	4 to 20 mA or 1 to 5 V	Nil	○	○	Mode A (Standard)
		J	○	○	Mode B
	0-135 Ω to 0-1 kΩ Potentiometer input or 0 to 5 V	F	○		Mode A
		K	○		Mode B
	0 to 10 V	G	○		Mode A
		N	○		Mode B
2 to 10 V	H	○		Mode A	
	M	○		Mode B	
Auxiliary limit switch (Select limit switch depending on the load)	L0	○	○	For standard signal	
	L2	○	○	For micro load signal	
Alarm output board	EA	○	○	EI and EA	
4 to 20 mA Indication signal board	EI	○	○	cannot be used together.	

*Auxiliary limit switch: Please refer to the specifications.

WIRING (OPTION)

L0, L2	Auxiliary limit switch	EA	Alarm output board	EI	4 to 20 mA Indication signal board
	<p>At CLOSE side, LC and LS is ON. At OPEN side, LC and LO is ON.</p> <p>ON point can be reset by adjusting the cam.</p>		<p>NO : Normally open NC : Normally closed</p> <p>Alarm SW will be ON, when overload protector works.</p> <p>Error → 11 and 12 is ON. Normal → 11 and 13 is ON.</p> <p>Cannot be used with EI option.</p>		<p>Actuator wiring: PDX, PHX</p> <p>Actuator Positioner board</p> <p>ZERO SPAN</p> <p>Unavailable + ← + 0~1mA - ← -</p> <p>4~20mA + ← + - ← -</p> <p>11 + 4~20mA 12 - EI Option</p> <p>The angle range of 4 to 20 mA can be adjusted by ZERO / SPAN trimmer on control board. Output signal (0 to 1 mA) cannot be used together.</p>

ELECTRIC ACTUATOR SPECIFICATIONS

3 way valve: SHUT / Position①, OPEN / Position②

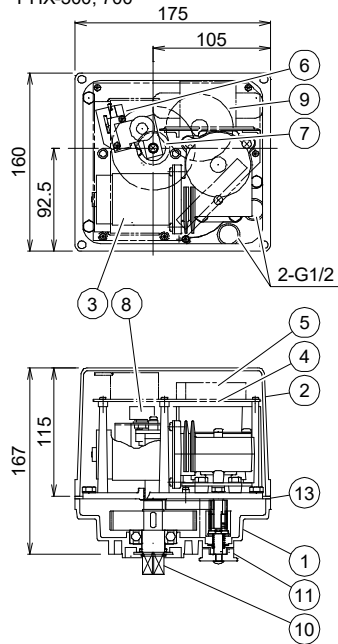
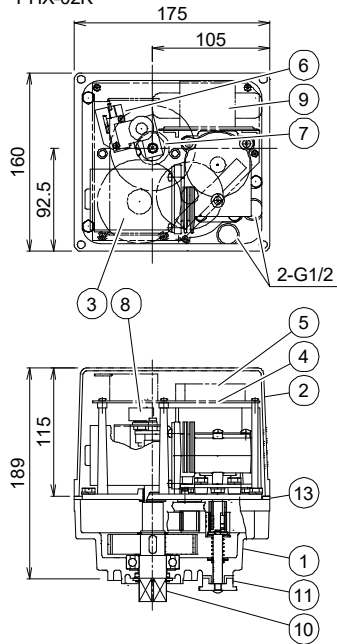
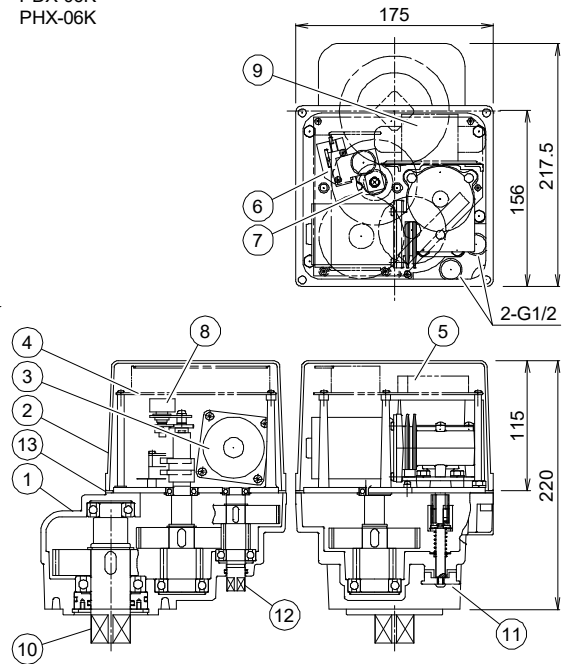
DIMENSIONS**PDX PHX**PDX-300, 700
PHX-300, 700PDX-02K
PHX-02KPDX-06K
PHX-06K**Parts name**

1	Body	5	Terminal block	9	Transformer	13	Rubber packing
2	Motor cover	6	Limit switch	10	Drive shaft		
3	Motor	7	SW setting cam	11	Manual clutch		
4	Control board	8	Potentiometer	12	Manual shaft (For 06K)		

INSTALLATION, OPERATION & MAINTENANCE INSTRUCTIONS

HANDLING & STORAGE

①HANDLING

Proper care in handling the valve should be taken to prevent damage. Do not drop or throw it.

②STORAGE

- Store away from dust, moisture and direct sunlight. If possible, store in the original package.
- Do not remove a dust proof cap until the piping.

③CHECKING

- Check the product code, power supply, and voltage before installation.
- Make sure that the bolts are not loose.
- The DIP switch should be set up before the power is turned on. Do not touch unnecessary switches.

INSTALLATION

①PRECAUTIONS

- Flush the pipeline carefully before installing the valve. Foreign particles, such as sand or pieces of welding electrode, will damage the ball and seats.
- For valves with specified flow direction (V), check the arrows on the product before piping.
- When the flow path is subjected to a high pressure from arrow, it may leak slightly to the low pressure port. (L2)

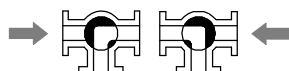

②PIPING FLANGES

- Gasket should be selected appropriately to suit the fluid, pressure and temperature. Use spring washer to prevent from decreasing surface pressure gasket when the temperature change happens frequently.
- Tighten all bolts using crossover method to load the joint evenly.

③ENVIRONMENT

- Do not install in place where corrosive gas is present or where vibration is heavy (0.5 G or more).
- When radiant heat causes the surface temperature of the control unit to exceed 55 °C, provide an appropriate shielding plate.
- If there is a possibility that the fluid and drive part freeze, please take measures to prevent freezing.

④POSITIONING

Should be positioned through 90° upward from horizontal. Provide space around the product to allow manual operation, inspection and replacement work.

Maintenance space for upper part of actuator.

PDX PHX

More than 120 mm

⑤OTHER NOTES

Until the wiring is completed there must be no condensation or flooding in the interior of the actuator, after piping. Protective caps on the cable gland are not waterproof.

TIGHTEN THE GLAND NUTS

- Check that there is no leakage from the gland packing.
- If it leakage, tighten gland nuts by alternately. Do not over-tighten the gland nuts.

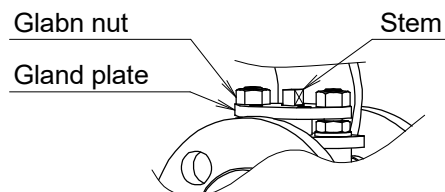

Valve size [mm]			Recommended torques [N·m]
BF	V	L2	
015 020 025	025	020 025	6
040 050	040 050	040 050	9
065 080 100	065 080 100	065 080 100	15
125 150	125 150	-	25
-	200	-	30

INSTALLATION, OPERATION & MAINTENANCE INSTRUCTIONS**WIRING****①PRECAUTIONS**

- Remove the actuator cover before wiring.
- Two G1/2 electrical connections are provided with a cable gland and plug. Usable cable size is $\Phi 6$ to 12 mm.
- When using a flexible tube, dew condensation may occur inside the actuator due to respiration from the inside of the tube and malfunction may result. Seal the flexible tube connector part with a sealant.
- Sealants that affect the electrical contacts should not be used inside the electric actuator.
- If long distance wiring or low voltage operation, check that terminal voltage is in the proper range.
- Input signal circuit is non-isolated.
Do not connect DC (minus) wire to other DC (minus) common.

②CONNECTION

- Do not wiring outdoors on a rainy day.
- Check the power supply and voltage.
Connect the signal as shown in the wiring diagram.
Do not connect unnecessarily terminal.
- Check whether the MODE change DIP SW on a circuit board substrate is set up correctly.
- When wiring, if wiring of a signal is mistaken, it will not operate correctly. Contact us when you use two valve or more by one controller or indicator.
- Actuator should be electrically grounded.
Use the terminal marked (\oplus) inside the actuator.

PREVENT DEW CONDENSATION

- When installing the cover after wiring, perform the bolt by the temporary tightening procedure and the permanent tightening procedure to tightly and securely tighten the rubber packing so that water does not enter from the outside.
- Tighten the cable gland nut so that there is no leakage from the wire entrance.

CONTROL**①INPUT SIGNAL**

- Use shielded wire for signal wiring where high level noise is generated or when the wiring distance is long.
- Control with a 1 to 5 V input signal becomes an input resistance 250 Ω . Provide a voltage that can safely 20mA or more than.

②DC POWER SUPPLY

- Battery or full wave rectification can be used.
- Consider an inrush current of motor.
(It is 1.5 to 3 times of consumed current.)
- When using a DC voltage, be selected the wire thickness by the wiring distance.
- Do not use power supply that require more than 1 second with rise and fall time.

③INPUT SIGNAL AND OPERATION MODE

The input signal and operation mode are set as follows. (Factory shipped)

Input signal	4 to 20 mA or 1 to 5 V
Operation mode	Mode A
Operation	SHUT by decreased signal. OPEN by increased signal.

OPERATION**①TESTING**

- Make sure that power supply voltage is correct. Also check operating position, wiring, speed and signals.
- During trial operation, check that valve movement and output signal are correct.

②CONFIRM THE OPERATING CONDITION

- Adjust fluid condition, controller setting, sensor etc. so that stable control is achieved.
- When used in an unstable control state, the life of the actuator and the valve will be shortened.
- The desired control state is stable at the target value.
Adjust the PID setting value of the controller when overshooting the target value greatly, when not converging for a long time or hunting operation. Also, when the time delay is large, please consider the sensor position.

③DUTY CYCLE (PDX)

Confirm that the operation frequency is within the specified duty cycle.
Use beyond the load time rate range will affect product life. Also, it may cause burnout.

Duty cycle is a value that regulates the opening / closing frequency of the actuator.
The meaning of 50 % 30 minutes for Duty cycle is that 15 minutes (50 % of 30 minutes) operation is possible. The calculated value obtained by dividing 15 minutes by the operation time is the number of times of operation within 30 minutes.

④ATTENTION

- Do not change an unnecessary dip switch.
- Keep power supplied for built-in space heater to prevent condensation inside actuator.
- Do not touch the moving parts of actuator in operation.
- Never put anything on the actuator or make it into a foothold.

INSTALLATION, OPERATION & MAINTENANCE INSTRUCTIONS**MANUAL OPERATION**

① PRECAUTIONS

- Be sure to turn off the power before manual operation.
- Operate manually with reference to the opening degree label. Do not turn beyond the fully open / fully closed position. Operation failure may occur during automatic operation.

② THE WAY OF OPERATION

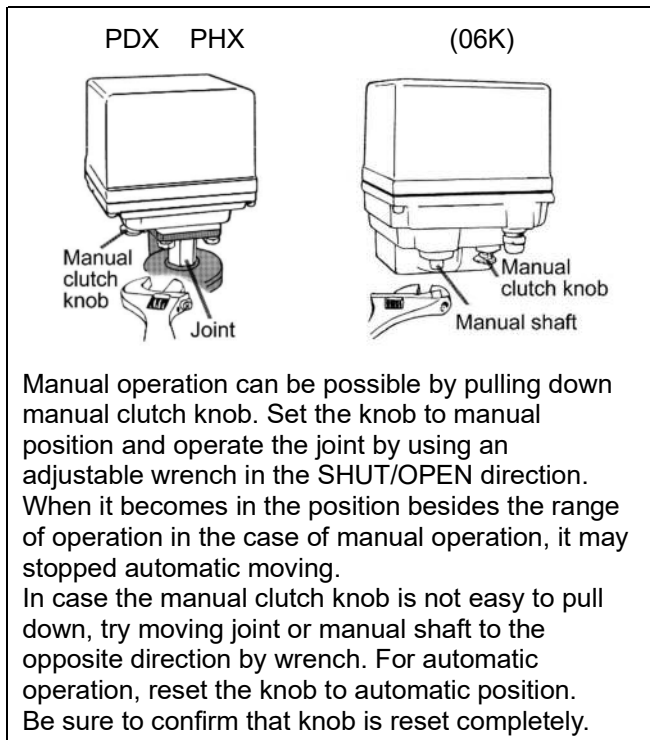

Before automatic operation, be sure to remove wrench.

MAINTENANCE

- To prevent electric shock, be sure to turn off the power when removing the actuator cover.
- Do the routine maintenance at least once in half a year.

Inspection items

- Confirm operation of opening and closing.
- Confirm that an actuator is not hot excessively.
- Confirm existence of abnormal noise and vibration during operation.
- Confirm whether screws are loose or not.
- Confirm that water or condensation no remains in the actuator.
- Confirm the fluid temperature or pressure.
- Confirm the leak from valve stem.
- Confirm the bolt tightening torque.

INSTALLATION, OPERATION & MAINTENANCE INSTRUCTIONS

TROUBLE SHOOTING

Problem	Cause	Solution
Actuator does not move.	Faulty wiring.	Correct the wiring.
	Voltage and input signal are not coming.	Check the voltage and input signal.
	Incorrect voltage.	When it's burned out by excess voltage, replace the actuator.
	Connection or wiring is not correct.	Correct the miswiring and misconnection. Be careful not to mistake the plus and minus of wiring.
	Short the circuit, contact failure.	Review wires and connection.
	Motor is too old.	Replace the actuator. Repair in our factory.
LED lamp (S or O) on the board is lit, but the motor does not move. PDX		
Operation is unstable.	Excess surge or voltage was applied.	<ul style="list-style-type: none"> • Replace the control board or limit switch. (Repair in our factory) • Replace the actuator.
	Rainwater entered the actuator.	<ul style="list-style-type: none"> • Dry the inside. • Replace the actuator.
	Added high harmonics noise from an inverter.	Attachment a filter for each inverter maker option.
	Effect of high level noise.	Use the shielded wire and ground the wiring. Separate signal wire from power line.
Stop in the mid position. (Input signal 1 to 5 V)	Signal voltage source capacity shortage.	Use a voltage source that can be made to flow more than 20 mA. Please contact us.

Problem	Cause	Solution
Stop in the mid position.	<ul style="list-style-type: none"> • Biting of valve seat. • The scale has adhered to the valve ball. 	Remove a foreign object.
	Overload protector runs because of over-torque.	Motor protection circuit returns by the signal of operation of an opposite direction. Turn on the power again.
Alarm LED is lit.		
Stop automatic moving after manual operation.	Manual clutch knob is not reset.	Reset manual clutch knob.
	Out of operating range. (06K)	Reset by manual operation.
Leakage from valve body	<ul style="list-style-type: none"> • Valve cap get loose. • Valve body is damaged. 	Replace the valve.
Leakage from valve seat	Seat is worn or damaged.	Replace the valve seat.
Leakage from valve stem	Stem packing is worn or distorted.	Tighten the gland nut.
		Replace the packing.

For more information contact
NIPPON VALVE CONTROLS, INC. for consultation.