



# Instruction manual

NIPPON VALVE CONTROLS, INC. **Pneumatic Actuated Ball Valve BR BS GS VR TR LR T3 L3**

SP-1555

**Please read this manual before installation and use.**

## GENERAL

Flanged ball valve with pneumatic actuator.

<b>Actuator</b>	<b>Valve</b>	
Double-acting type	BR type	For various fluids and general use.
PND TAD	BS type	For Wafer.
Single-acting type	VR type	For control.
(Airless: SHUT)	GS type	For Wafer. (JIS 10K / 20K)
PSO TAO	TR type	For mixing / dividing.
Single-acting type	LR type	For mixing / dividing.
(Airless: OPEN)	T3 Type	Trunnion structure. (with flow paths)
PSC TAC	L3 type	Trunnion structure.

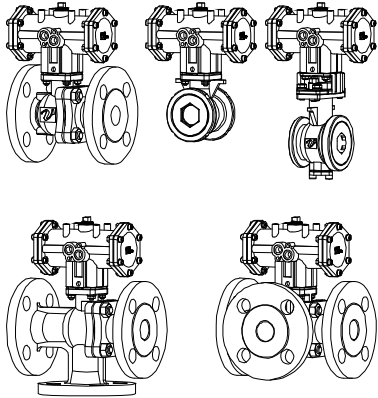

## PRODUCT CODE



BR type	<input type="checkbox"/>	<input type="checkbox"/>	<input type="checkbox"/>	<input type="checkbox"/>	<input type="checkbox"/>	<input type="checkbox"/>	<input type="checkbox"/>	-	<input type="checkbox"/>	<input type="checkbox"/>	<input type="checkbox"/>	<input type="checkbox"/>	<input type="checkbox"/>
BS type (Full port)	<input type="checkbox"/>	<input type="checkbox"/>	<input type="checkbox"/>	<input type="checkbox"/>	<input type="checkbox"/>	<input type="checkbox"/>	<input type="checkbox"/>	-	<input type="checkbox"/>	<input type="checkbox"/>	<input type="checkbox"/>	<input type="checkbox"/>	<input type="checkbox"/>
(Standard port)	<input type="checkbox"/>	<input type="checkbox"/>	<input type="checkbox"/>	<input type="checkbox"/>	<input type="checkbox"/>	<input type="checkbox"/>	<input type="checkbox"/>	R	<input type="checkbox"/>	<input type="checkbox"/>	<input type="checkbox"/>	<input type="checkbox"/>	<input type="checkbox"/>
VR type	<input type="checkbox"/>	<input type="checkbox"/>	<input type="checkbox"/>	<input type="checkbox"/>	<input type="checkbox"/>	<input type="checkbox"/>	<input type="checkbox"/>	-	<input type="checkbox"/>	<input type="checkbox"/>	<input type="checkbox"/>	<input type="checkbox"/>	<input type="checkbox"/>
(Standard port)	<input type="checkbox"/>	<input type="checkbox"/>	<input type="checkbox"/>	<input type="checkbox"/>	<input type="checkbox"/>	<input type="checkbox"/>	<input type="checkbox"/>	R 0 1 5	<input type="checkbox"/>	<input type="checkbox"/>	<input type="checkbox"/>	<input type="checkbox"/>	<input type="checkbox"/>
GS type (V-port)	<input type="checkbox"/>	<input type="checkbox"/>	<input type="checkbox"/>	<input type="checkbox"/>	<input type="checkbox"/>	<input type="checkbox"/>	<input type="checkbox"/>	V	<input type="checkbox"/>	<input type="checkbox"/>	<input type="checkbox"/>	<input type="checkbox"/>	<input type="checkbox"/>
(Full port)	<input type="checkbox"/>	<input type="checkbox"/>	<input type="checkbox"/>	<input type="checkbox"/>	<input type="checkbox"/>	<input type="checkbox"/>	<input type="checkbox"/>	-	<input type="checkbox"/>	<input type="checkbox"/>	<input type="checkbox"/>	<input type="checkbox"/>	<input type="checkbox"/>
(Standard port)	<input type="checkbox"/>	<input type="checkbox"/>	<input type="checkbox"/>	<input type="checkbox"/>	<input type="checkbox"/>	<input type="checkbox"/>	<input type="checkbox"/>	R	<input type="checkbox"/>	<input type="checkbox"/>	<input type="checkbox"/>	<input type="checkbox"/>	<input type="checkbox"/>
TR type	<input type="checkbox"/>	<input type="checkbox"/>	<input type="checkbox"/>	<input type="checkbox"/>	<input type="checkbox"/>	<input type="checkbox"/>	<input type="checkbox"/>	-	<input type="checkbox"/>	<input type="checkbox"/>	<input type="checkbox"/>	<input type="checkbox"/>	<input type="checkbox"/>
LR type	<input type="checkbox"/>	<input type="checkbox"/>	<input type="checkbox"/>	<input type="checkbox"/>	<input type="checkbox"/>	<input type="checkbox"/>	<input type="checkbox"/>	-	<input type="checkbox"/>	<input type="checkbox"/>	<input type="checkbox"/>	<input type="checkbox"/>	<input type="checkbox"/>
T3 type	<input type="checkbox"/>	<input type="checkbox"/>	<input type="checkbox"/>	<input type="checkbox"/>	<input type="checkbox"/>	<input type="checkbox"/>	<input type="checkbox"/>	-	<input type="checkbox"/>	<input type="checkbox"/>	<input type="checkbox"/>	<input type="checkbox"/>	<input type="checkbox"/>
L3 type	<input type="checkbox"/>	<input type="checkbox"/>	<input type="checkbox"/>	<input type="checkbox"/>	<input type="checkbox"/>	<input type="checkbox"/>	<input type="checkbox"/>	-	<input type="checkbox"/>	<input type="checkbox"/>	<input type="checkbox"/>	<input type="checkbox"/>	<input type="checkbox"/>
	(1)	(2)	(3)	(4)	(5)	(6)	(7)	(8)	(9)	(10)	(11)	(12)	

(1) Actuator PND TAD PSO TAO PSC TAC	(6) Body material T : SCS13A U : SCS14A	(10) Option FR : Filter Regulator Unit LB : Limit Switch Box LC : Built-in limit switch EX : Smart Positioner EN : Positioner EP : Positioner ER, ER, ET, EU : Smart Positioner
(2) Valve BR BS VR GS TR LR T3 L3	(7) Ball material T : SCS13A / SUS304 U : SCS14A / SUS316	(11) Positioner control pattern (TAD) A : SHUT by 4 mA ↔ OPEN by 20 mA B : SHUT by 20 mA ↔ OPEN by 4 mA
(3) Voltage 9 : Air	(8) Seat material F : F-PTFE G : R-PTFE R : R-F-PTFE K : PEEK I : API	(11) Positioner control pattern (PSO, TAO) C : OPEN by 20 mA ↔ SHUT by 4 mA (Airless: SHUT) D : OPEN by 4 mA ↔ SHUT by 20 mA (Airless: SHUT)
(4) Sizing code 0 : Standard 1 : Light 2 : Heavy	(9) Size [mm] ex. 25 A → 025	(11) Positioner control pattern (PSC, TAC) E : SHUT by 4 mA ↔ OPEN by 20 mA (Airless: OPEN) T : SHUT by 20 mA ↔ OPEN by 4 mA (Airless: OPEN)
(5) Connection 1 : JIS 10K 3 : JIS 20K		(12) Flow paths (T3) a to d : 3 way valve flow

## VALVES SPECIFICATIONS

 Water 
  Oil 
  Air, Gas 
  Steam 
  Chemicals 
  Sea water 
  Slurry 
  Negative pressure

BR BS type

Valve type	BR			BS			
Design	2-way, Full port			2-way, Wafer			
				Full port	Standard port		
Connection	JIS10K Flanged-end	JIS20K Flanged-end		JIS Flanges 10K			
Fluid							
Max pressure	1 MPa	2 MPa		1 MPa			
Size [mm]	015 to 150		015 to 080	015 to 80		R100 to R150	
Material	Body	SCS13A	SCS14A	SCS13A	SCS13A	SCS14A	SCS13A
	Ball	SCS13A SUS304	SCS14A SUS316	SCS13A	SCS13A	SCS14A	SCS13A
	Seat	F-PTFE	R-PTFE	R-F-PTFE	F-PTFE	R-PTFE	R-F-PTFE
Stem seal	Packing	R-PTFE			R-PTFE		
	O-ring	FKM			FKM		

The optional for steam fluids.

Valve type	Option code	O-ring
BR BS	ST	Replace (Steam resistant FKM)

## PRESSURE &amp; TEMPERATURE RATING

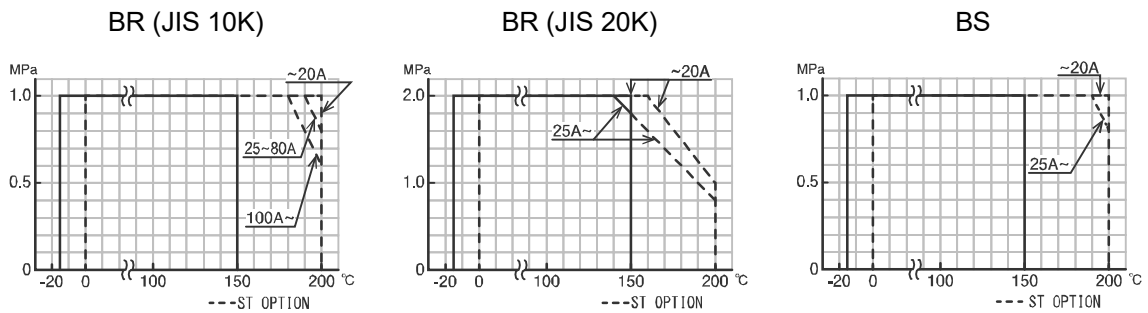

Note) Insulation options are required for use with fluids more than 150 °C.

## INHERENT FLOW CHARACTERISTIC (BS)

R100 to R150 mm

Cv value (%)

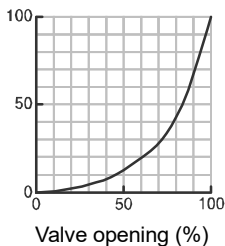

Range ability 30:1

**VALVES SPECIFICATIONS**

Water 
 Oil 
 Air, Gas 
 Steam 
 Chemicals 
 Sea water 
 Slurry 
 Negative pressure

VR type

Valve type	VR		
Design	2-way, V-port		
Connection	JIS10K Flanged-end		
Fluid			
Max pressure	1 MPa		
Size [mm]	R015	015 to 080	
	Material	Body	SCS14A
		Ball	SUS316 SCS14A
		Seat	R-PTFE R-F-PTFE
Stem seal	Packing	R-PTFE	
	O-ring	FKM	

The optional for steam fluids.

Valve type	Option code	O-ring
VR	ST	Replace (Steam resistant FKM)

**PRESSURE & TEMPERATURE RATING**

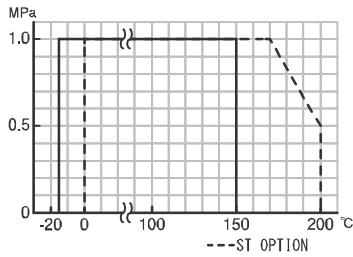

Note) Insulation options are required for use with fluids more than 150 °C.

**INHERENT FLOW CHARACTERISTIC**

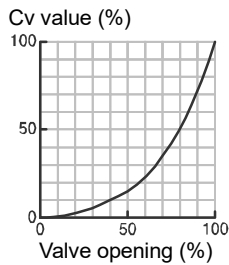





Range ability

VR-1UUG R 015                      100:1  
 VR-1UUG - 015 to 080              50:1

## VALVES SPECIFICATIONS

 Water 
  Oil 
  Air, Gas 
  Steam 
  Chemicals 
  Sea water 
  Slurry 
  Negative pressure

GS type

Valve type	GS					
Design	2-way, Wafer					
	V-port	Full port	Standard port			
Connection	JIS Flanges 10K / 20K					
Fluid	    					
Max pressure	2 MPa					
Size [mm]	V015 to V032	015 to 080	R040 to R150			
	Material					
	Body	SCS14A				
	Ball	SCS14A (HCr plated)				
	Seat	R-PTFE	PEEK	API	R-PEEK	SUS316 + Stellite
Stem seal	Packing	R-PTFE				

Note) API cannot be used with steam fluid.

## PRESSURE &amp; TEMPERATURE RATING

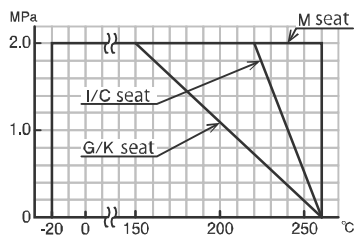

Note) • Option for use in fluid temperature more than 170 °C.  
 • We prefer to K seat depends on pressure or environmental conditions. Please consult us for your specifications.

## SEAT LEAKAGE VOLUME (JIS B 2005-4)

	Seat material	Leakage rate	Remarks
G	R-PTFE	None	
K	PEEK		
I	API		
C	R-PEEK	$10^{-4} \times \text{rated Cv value} \times 10^{-3}$ or less.	Class IV $\times 10^{-3}$ or less.
	R-PEEK (V-port)	$10^{-4} \times \text{rated Cv value} \times 10^{-3} \times 8$ or less.	Class IV $\times 10^{-3} \times 8$ or less.
M	SUS316 + Stellite	$10^{-4} \times \text{rated Cv value}$ or less.	Class IV or less.
	SUS316 + Stellite (V-port)	$10^{-4} \times \text{rated Cv value} \times 8$ or less.	Class IV $\times 8$ or less.

## INHERENT FLOW CHARACTERISTIC

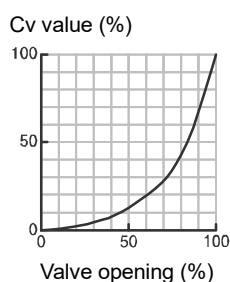

## Range ability

GS-3UU □ V 015 to 032    50:1    (V-port)  
 GS-3UU □ - 015 to 080    200:1    (Full port)  
 GS-3UU □ R 040 to 150    100:1    (Standard port)

**VALVES SPECIFICATIONS**

Water 
 Oil 
 Air, Gas 
 Steam 
 Chemicals 
 Sea water 
 Slurry 
 Negative pressure

TR LR type

Valve type		TR LR	
Design		3-way, Full port	
Connection		JIS10K Flanged-end	
Fluid			
Max pressure		1 MPa	
Size [mm]		020 to 040	050 to 100
Material	Body	SCS13A	
	Ball	SUS304	SCS13A
	Seat	R-PTFE	
Stem seal	Packing	R-PTFE	
	O-ring	FKM	

The optional for steam fluids.

Valve type	Option code	O-ring
TR LR	ST	Replace (Steam resistant FKM)

**PRESSURE & TEMPERATURE RATING**

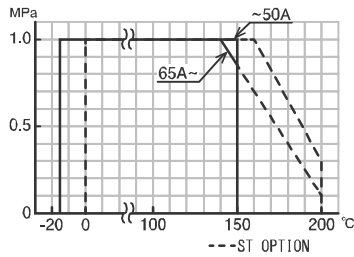

Note) Insulation options are required for use with fluids more than 150 °C.

**INHERENT FLOW CHARACTERISTIC**

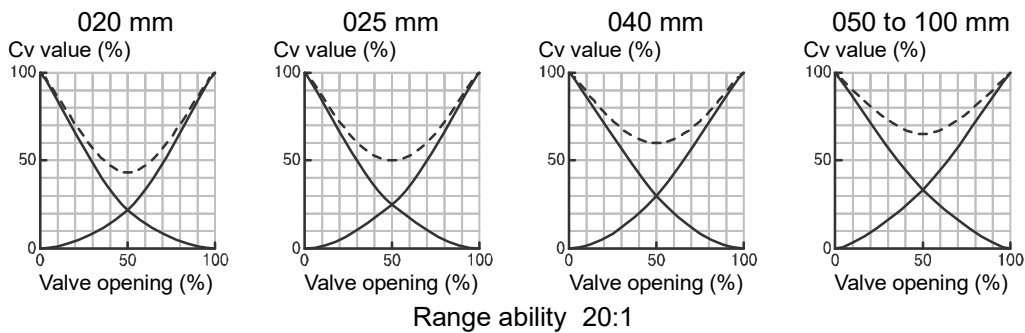

**FLOW PATHS (Position① / P1) (Position② / P2)**

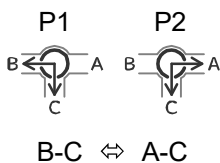

Note) When a closed path is exposed to high pressure, it may leak slightly to an open path.

**VALVES SPECIFICATIONS**

Water 
 Oil 
 Air, Gas 
 Steam 
 Chemicals 
 Sea water 
 Slurry 
 Negative pressure

T3 L3 type

Valve type	T3 L3	
Design	3-way, Full port	
Connection	JIS10K Flanged-end	
Fluid		
Max pressure	1 MPa	
Size [mm]	025 to 150	
Material	Body	SCS13A
	Ball	SCS13A
	Seat	R-PTFE
Stem seal	Packing	PTFE

The optional for steam fluids.

Valve type	Option code	O-ring
T3 L3	ST-VF	Add (Steam resistant FKM)

**PRESSURE & TEMPERATURE RATING**

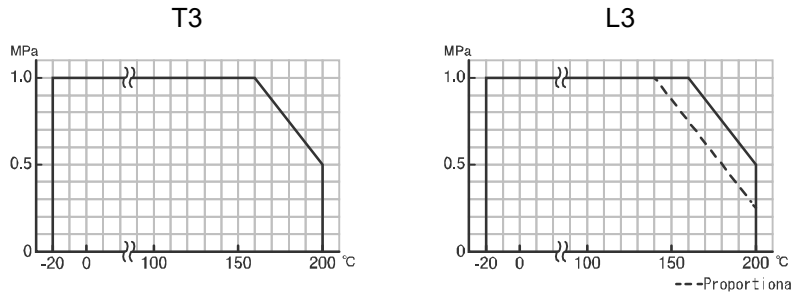

Note) Insulation options are required for use with fluids more than 170 °C.

**INHERENT FLOW CHARACTERISTIC (L3)**

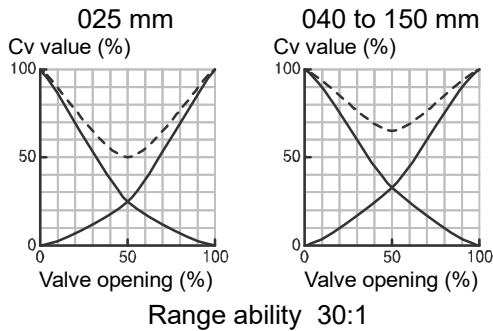

**FLOW PATHS (Position① / P1) (Position② / P2)**

T3				L3	
Code: a	Code: b	Code: c	Code: d		
A-B ⇔ B-C	A-C ⇔ A-B	B-C ⇔ A-B-C	A-B-C ⇔ A-C	B-C ⇔ A-C	

**PNEUMATIC ACTUATOR SPECIFICATIONS**

3 way valve: SHUT / Position①, OPEN / Position②

## PND type

Classification	Double-acting type			
Actuator type	PND-03S	PND-03D	PND-04D	PND-05D
Weight [kg]	0.2	0.3	0.5	0.8
Air consumption (round-trip) [ℓ]	0.05	0.08	0.19	0.35
Operation time [s]	Less than 1.			
Operation	SHUT by air to port A. ↔ OPEN by air to port B.			
Air pressure	0.4 to 0.7 MPa			
Piping connection	Rc 1/8			
Method of operation	Scotch yoke			
Housing material	PPS resin			
Ambient temperature	-10 to 50 °C (Please be careful when you use in 5 °C or less, so that there no freeze.)			
Manual operation	Operates the upper shaft of the actuator directly.			

## PSO PSC type

Classification	Single-acting type (Spring-return)				
Actuator type	PSO - 03S PSC - 03S	PSO - 03D PSC - 03D	PSO - 04D PSC - 04D	PSO - 05D PSC - 05D	PSO - 05W PSC - 05W
Weight [kg]	0.2	0.4	0.6	1.2	1.8
Air consumption (round-trip) [ℓ]	0.03	0.04	0.1	0.2	0.53
Air exit	One side	Both sides			
Operation time [s]	Less than 1.				
Operation	PSO : OPEN by air to intake port. ↔ SHUT by spring-return. (Airless: SHUT) PSC : SHUT by air to intake port. ↔ OPEN by spring-return. (Airless: OPEN)				
Air pressure	0.4 to 0.7 MPa				
Piping connection	Rc 1/8				
Method of operation	Scotch yoke				
Housing material	PPS resin				
Ambient temperature	-10 to 50 °C (Please be careful when you use in 5 °C or less, so that there no freeze.)				
Manual operation	No manual operation.				

**PNEUMATIC ACTUATOR SPECIFICATIONS**

3 way valve: SHUT / Position①, OPEN / Position②

## TAD type

Classification	Double-acting type						
Actuator type	TAD-040	TAD-050	TAD-063	TAD-080	TAD-100	TAD-125	TAD-160
Weight [kg]	0.9	1.3	2.1	3.4	6.1	9.8	18.2
Air consumption (round-trip) [ℓ]	0.11	0.18	0.34	0.66	1.36	2.72	5.56
Operation	SHUT by air to port A. ↔ OPEN by air to port B.						
Air pressure	0.4 to 0.7 MPa						
Piping connection	Rc 1/8	Rc 1/4					
Method of operation	Rack-and-pinion	Scotch yoke					
Housing material	Aluminum alloy						
Ambient temperature	-10 to 50 °C (Please be careful when you use in 5 °C or less, so that there no freeze.)						
Manual operation	Operates the upper shaft of the actuator directly.						

## TAO TAC type

Classification	Single-acting type (Spring-return)						
Actuator type	TAO-040 TAC-040	TAO-050 TAC-050	TAO-063 TAC-063	TAO-080 TAC-080	TAO-100 TAC-100	TAO-125 TAC-125	TAO-160 TAC-160
Weight [kg]	2.3	3	4.9	8.5	16.4	27.6	51.2
Air consumption (round-trip) [ℓ]	0.23	0.34	0.67	1.26	2.62	4.44	8.77
Operation	TAO : OPEN by air to intake port. ↔ SHUT by spring-return. (Airless: SHUT) TAC : SHUT by air to intake port. ↔ OPEN by spring-return. (Airless: OPEN)						
Air pressure	0.4 to 0.7 MPa						
Piping connection	Rc 1/4						
Method of operation	Rack-and-pinion	Scotch yoke					
Housing material	Aluminum alloy						
Ambient temperature	-10 to 50 °C (Please be careful when you use in 5 °C or less, so that there no freeze.)						
Manual operation	No manual operation.	Option: MT (Manual handle unit)					

## PNEUMATIC ACTUATOR SPECIFICATIONS

3 way valve: SHUT / Position①, OPEN / Position②

## OPTIONAL PARTS

Classification	Code	PND	PSO	PSC	TAD	TAO	TAC		
Speed Controller with bypass valve (Housing material: PPS)	BS				○				
FR Unit (Regulator with Filter) TA2-FR (KONAN)	FR	○	○	○	○	○	○		
Limit Switch Box (Standard load signal)	LB	○	○	○	○	○	○		
Built-in limit switch	LC				○	○	○		
Explosion Proof Limit Switch, VCX7001 (azbil) Ex d e II C T6	LR				○	○	○		
Speed Controller (with One-touch Fitting) One set	SE	○	○	○	○	○	○		
Speed Controller (with One-touch Fitting) Two sets	SS	○			○				
Speed Controller (with One-touch Fitting) Dual Speed Controller	SF		○	○		○	○		
Manual handle unit (Except 040)	MT					○	○		
Sealing the spring unit. (Oil-free)	92					○	○		
Smart positioner (Except 03S)	EX		○	○					
Explosion Proof Electro-Pneumatic Positioner EXd II BT5 (TIIS)	EN				○	○	○		
Explosion Proof Electro-Pneumatic Positioner Ex dmb II B T5 (TIIS)	EP				○	○	○		
Smart positioner	ES				○				
	ER					○	○		
Smart positioner (with 4 to 20 mA DC, output)	ET				○				
	EU					○	○		
Positioner operation (Input signal: 4 to 20 mA DC)	EX		SHUT by 4 mA. ↔ OPEN by 20 mA.	A			○		
			SHUT by 20 mA. ↔ OPEN by 4 mA.	B			○		
			OPEN by 20 mA. ↔ SHUT by 4 mA. (Airless: SHUT)	C		○		○	
			OPEN by 4 mA. ↔ SHUT by 20 mA. (Airless: SHUT)	D		○		○	
			SHUT by 4 mA. ↔ OPEN by 20 mA. (Airless: OPEN)	E			○		○
			SHUT by 20 mA. ↔ OPEN by 4 mA. (Airless: OPEN)	T			○		○
	ES	*1	SHUT by 4 mA. ↔ OPEN by 20 mA. (Airless: HOLD)	A				○	
			SHUT by 20 mA. ↔ OPEN by 4 mA. (Airless: HOLD)	B				○	
	ET	*2	SHUT by 20 mA. ↔ OPEN by 4 mA. (Airless: HOLD)	W				○	
			SHUT by 4 mA. ↔ OPEN by 20 mA. (Airless: OPEN)	Y					○
	ER	*1	OPEN by 20 mA. ↔ SHUT by 4 mA. (Airless: SHUT)	C				○	
			OPEN by 4 mA. ↔ SHUT by 20 mA. (Airless: SHUT)	D				○	
			SHUT by 4 mA. ↔ OPEN by 20 mA. (Airless: OPEN)	Y					○
		*2	SHUT by 4 mA. ↔ OPEN by 20 mA. (Airless: OPEN)	E					○
SHUT by 20 mA. ↔ OPEN by 4 mA. (Airless: OPEN)			T					○	
OPEN by 4 mA. ↔ SHUT by 20 mA. (Airless: SHUT)			X				○		
5-Port Solenoid Valve (with speed controller, silencer)	Voltage: 100V AC		1S	○	○	○			
	Voltage: 200V AC		2S	○	○	○			
	Voltage: 110V AC		3S	○	○	○			
	Voltage: 220V AC		4S	○	○	○			
	Voltage: 24V DC		5S	○	○	○			

Positioner operation (ES, ER, ET, EU) \*1 0 mA: SHUT  
\*2 0 mA: OPEN

**PNEUMATIC ACTUATOR SPECIFICATIONS**

3 way valve: SHUT / Position①, OPEN / Position②

## SOLENOID VALVE (PND-05D) (TAD, TAO, TAC)

Classification			Code (□: Voltage)	
5-port Solenoid Valve Return (with bypass valve)	Lead wire	4N3S102K-L□	N43SL□	□: Voltage 1 : 100V AC 3 : 200V AC 5 : 24V DC
	DIN Connector	4N3S102K-D□	N43SD□	
	DIN Connector (with lamp)	4N3S102K-N□	N43SN□	
	Watertight cover	4N3S102K-W□	N43SW□	
5-port Explosion proof solenoid valve Return (with bypass valve)	Conduit	4N4S102K-E01-H□B0-R	4N4S01-□B0, NO	
	Flame proof packing (Cable size Φ9.5 to 10.4 mm)	4N4S102K-E10-H□B0-R	4N4S10-□B0, NO	

## Operate by solenoid valve (Normally Open)

PND, TAD	SHUT by solenoid off. ↔ OPEN by power to solenoid.
PSO, TAO (Airless: SHUT)	OPEN by power to solenoid. ↔ SHUT by solenoid off. (Spring-return)
PSC, TAC (Airless: OPEN)	SHUT by power to solenoid. ↔ OPEN by solenoid off. (Spring-return)

## INSTALLATION, OPERATION & MAINTENANCE INSTRUCTIONS

### HANDLING & STORAGE

#### ①HANDLING

Do not drop or throw the product as it may break.

#### ②STORAGE

- Store away from dust, moisture and direct sunlight.
- If possible, store in the original package.
- Do not remove a dust proof cap until the piping.

#### ③CHECKING

- Check the product code before installation.
- Make sure that the bolts are not loose.

### INSTALLATION

#### ①PRECAUTIONS

- Flush the pipeline carefully before installing the valve. Foreign particles, such as sand or pieces of welding electrode, will damage the ball and seats.
- For valves with specified flow direction (VR, GS) or with ST / SC option, check the arrows on the product before piping.
- When the flow path is subjected to a high pressure from arrow, it may leak slightly to the low pressure port. (TR, LR)

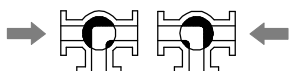

#### ②PIPING FLANGES

- Gasket should be selected appropriately to suit the fluid, pressure and temperature.
- Use spring washer to prevent from decreasing surface pressure gasket when the temperature change happens frequently.
- Tighten all bolts using crossover method to load the joint evenly.
- Wafer type ball valve is put between two seats of flanged-end and tightened with long bolts. (BS, GS)

#### ③ENVIRONMENT

- Do not install in place where corrosive gas is present or where vibration is heavy (0.5 G or more).
- When radiant heat causes the surface temperature of the control unit to exceed 50 °C, provide an appropriate shielding plate.
- If there is a possibility that the fluid and drive part freeze, please take measures to prevent freezing.
- For single-acting type, prevent water and dust from coming into air exit.

#### ④POSITIONING

Should be positioned through 90° upward from horizontal. Provide space around the product to allow manual operation, inspection and replacement work.

#### ⑤CAUTIONS FOR MAINTENANCE (GS, T3, L3)

Do not keep warm for maintenance of the valve gland.

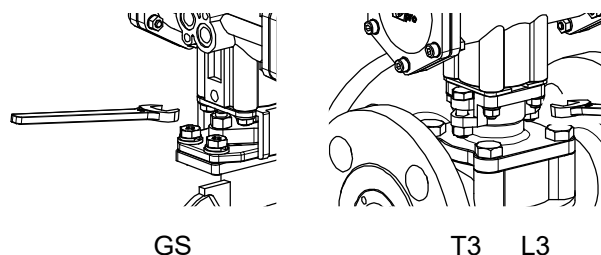

#### TIGHTEN THE GLAND NUTS (GS, T3, L3)

- Check that there is no leakage from the gland packing.
- If it leakage, tighten gland nuts by alternately. Do not over-tighten the gland nuts.

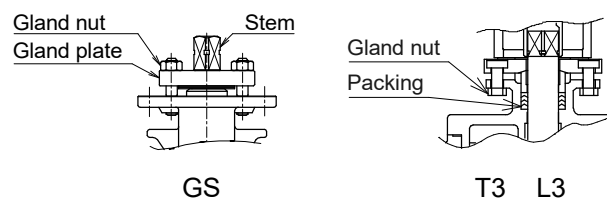

	Valve size [mm]				Recommended torques [N·m]
	GS	T3	L3		
V015 V020	015 020	-	-	-	2
V025 V032	025 032	R040	025	025	3.5
-	040 050	R050 R065	040	040 050	7
-	065 080	R080 R100	050 065	065 080	10
-	-	R125 R150	080 100	100 125	14
-	-	-	125 150	150	20

## INSTALLATION, OPERATION & MAINTENANCE INSTRUCTIONS

### AIR PIPING

- Pneumatic actuator has an air supply ports to operate piston.

#### Double-acting type

PND : Rc 1/8

Coupling OD  
less than 14.5 Φ

TAD-040 : Rc 1/8

TAD-050 to 160 : Rc 1/4

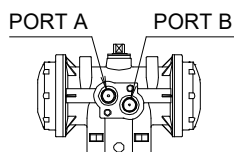

#### Single-acting type

PSO, PSC : Rc 1/8

TAO, TAC : Rc 1/4

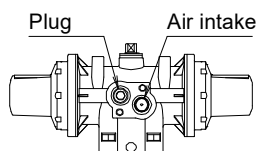

- Piping of double-acting type is connected by seal tape on PORT A / B. Piping of single-acting type is put seal tape only on the air intake port.
- PND, PSO, PSC: PPS resin air supply port may be damaged if over tighten, please lightly tighten by hand.
- Never put anything on the actuator or make it into a foothold.

### OPERATION

#### ①AIR SOURCE

- Use the filtered dry air (less than 40 μ).
- Extra attention is needed where it's cold climate (below 5 °C).
- When air pressure is high, reduce it to standard pressure (0.4 to 0.7 MPa). Air pressure should not exceed 0.7 MPa during operation test.
- Capacity of compressor and air tank are to be calculated by capacity of piping and air consumption. A margin of 30 % is required.

#### ②TEST OPERATION

Check the operation of pneumatic actuator before fluid enters the piping.

Double-acting type	Stop the air from the air source. Release the residual pressure in the air cylinder. Open the air equalizer. Move the manual shaft of actuator with a wrench.
Single-acting type	Send the standard pressure air. Confirm the opening / closing operation by slowly moving the actuator.

#### ③TESTING

After piping, check following points.

- Piping is correct.
- Air or fluid leakage from connection. Flow direction of air is correct.
- Air pressure is in the range.
- Nothing interferes with operation when limit switch or solenoid damper is attached.

#### ④ATTENTION

The opening and closing operation of the pneumatic actuator is fast, which may affect the product life. Please adjust the operation time of pneumatic actuator using a speed controller.

Valve size [mm]	Adjustment of operation time.
Less than 040	More than 1 second
050 or more	More than 2 seconds

**INSTALLATION, OPERATION & MAINTENANCE INSTRUCTIONS****MANUAL OPERATION**

- Double-acting; stop the air supply and do not leave the air inside of cylinder.
- Single-acting; cannot be operated manually.

Optional code with the handle: TAO-MT, TAC-MT

- Before automatic operation, be sure to remove wrench.

**OPERATION (PND, TAD)**

After turning air pressure to 0, turn manual shaft slowly with a smooth-jawed wrench to check the direction of OPEN/SHUT position.

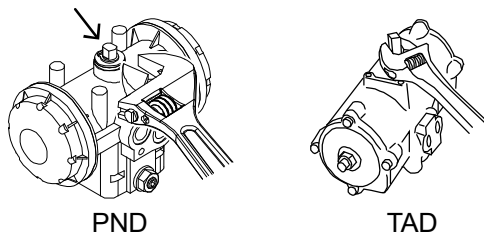
**MAINTENANCE**

- Do the routine maintenance at least once in half a year.
- Do not set or take spring unit parts apart after installing the pneumatic single-acting actuator.

Can be used with no oil supply.

- Confirm the air leakage.
- Confirm the air supply pressure.
- Confirm the dirt or grit inside of cylinder.

Lubrication Procedure (TAD, TAO, TAC)  
In case of lubricating, use turbine oil or the equivalent through a lubricator. (ISO VG 32.46).  
Once lubricate, do the regularly.

**Inspection items**

- Confirm operation of opening and closing.
- Confirm whether screws are loose or not.
- Confirm the fluid temperature or pressure.
- Confirm the leak from valve stem.
- Confirm the bolt tightening torque.

**TROUBLESHOOTING**

Problem	Cause	Solution
Fail to operate.	Air doesn't come out.	Supply air.
	Air pressure is too low.	Adjust to standard pressure level.
Stop in the mid position.	<ul style="list-style-type: none"> <li>• Biting of valve seat.</li> <li>• The scale has adhered to the valve ball.</li> </ul>	Remove a foreign object.
Leakage from valve body	<ul style="list-style-type: none"> <li>• Valve cap get loose.</li> <li>• Valve body is damaged.</li> </ul>	Replace the valve.
Leakage from valve seat	Seat is worn or damaged.	Replace the valve.
		Replace the valve seat.
Leakage from valve stem	Stem packing is worn or distorted.	Replace the valve.
		Replace the packing.
Leakage from valve gland GS T3 L3	Gland packing is worn or distorted.	Tighten the gland nut.
		Replace the gland packing.

For more information contact  
NIPPON VALVE CONTROLS, INC. for consultation.