

| Valve DN | S       | d  | L   | W   | N1 | N  | H   | Weight (kg) | Cv  | Actuator | Sizing code |
|----------|---------|----|-----|-----|----|----|-----|-------------|-----|----------|-------------|
| 15 A     | Rc 1/2  | 13 | 59  | 80  | 30 | 57 | 89  | 0.4         | 12  | PND-03S  | 0           |
| 20 A     | Rc 3/4  | 15 | 66  | 80  | 30 | 57 | 91  | 0.5         | 16  | PND-03S  | 0           |
| 25 A     | Rc 1    | 20 | 78  | 108 | 30 | 57 | 104 | 0.8         | 28  | PND-03D  | 0           |
| 32 A     | Rc1 1/4 | 25 | 87  | 108 | 30 | 57 | 114 | 1           | 47  | PND-03D  | 0           |
| 40 A     | Rc1 1/2 | 32 | 96  | 128 | 36 | 68 | 136 | 1.5         | 83  | PND-04D  | 0           |
| 50 A     | Rc 2    | 38 | 109 | 128 | 36 | 68 | 142 | 2.1         | 115 | PND-04D  | 0           |

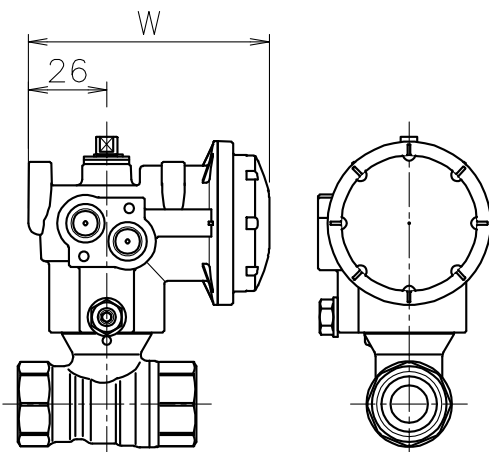
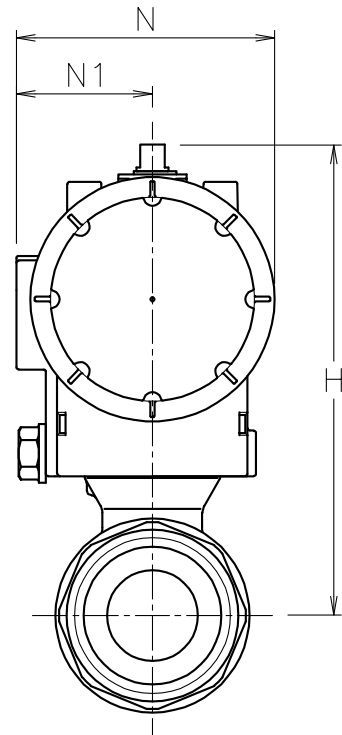
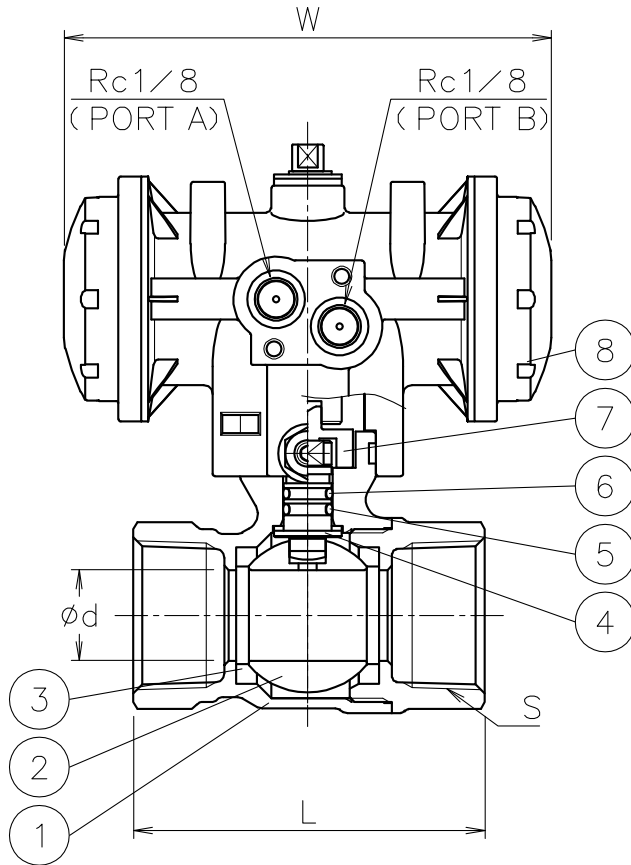

PND-03S

NOTE

- Air supply : 0.4~0.5 Mpa max 0.7 Mpa
- Actuator operation
  - Air to port A : SHUT
  - Air to port B : OPEN
- Coupling OD must be less than  $\phi 14.5$

| 8  | Actuator    | PPS body                        | 1     | PND     |
|----|-------------|---------------------------------|-------|---------|
| 7  | Joint       | SUS304                          | 1     |         |
| 6  | O' RING     | NBR                             | 1     |         |
| 5  | O' RING     | FKM                             | 1     |         |
| 4  | Stem        | Dezincification resistant brass | 1     |         |
| 3  | Seat        | F-PTFE                          | 2     |         |
| 2  | Ball        | C3604BD/C3771BE                 | 1     | PLTD    |
| 1  | Body        | C3771BE                         | 1     | PLTD    |
| No | DESCRIPTION | MATERIALS                       | REQ'D | REMARKS |

|           |      |    |  |           |  |     |         |                 |  |  |  |
|-----------|------|----|--|-----------|--|-----|---------|-----------------|--|--|--|
|           |      |    | APPR'D   | K.Y       | TITLE Threaded End Rc (double-acting type)<br>E type pneumatic actuated ball valve<br>MODEL PNDE-905YYF<br>Valve DN: 15~50 A |     |         |                 |  |  |  |
|           |      |    | CHK'D  | K.Y       |  |     |         |                 |  |  |  |
|           |      |    | DESIGN   |           |  |     |         |                 |  |  |  |
|           |      |    | DRAWN  | T.A       |  |     |         |                 |  |  |  |
| MARK      | DATE | BY | DATE   | '22-12-06 | SCALE  | NON | DWG No. | E-905YYF-NA1-EN |  |  |  |
| REVISIONS |      |    |  <b>NIPPON VALVE CONTROLS, INC.</b> |           |  |     |         |                 |  |  |  |
| MV-2987   |      |    |  |           |  |     |         |                 |  |  |  |