

Size [mm]	d	L	D	C	n-h	W	H1	Weight [kg]	Cv P1/P2	Actuator
20	20	150	100	75	4-15	115	85	3.5	24	Lever
25	25	170	125	90	4-19	145	102	5.6	40	Lever
40	40	200	140	105	4-19	220	124	8.7	100	Lever
50	50	230	155	120	4-19	220	133	12	170	Lever
65	65	260	175	140	4-19	320	159	18	240	Lever
80	80	280	185	150	8-19	320	171	21	380	Lever
100	100	340	210	175	8-19	430	204	33	680	Lever

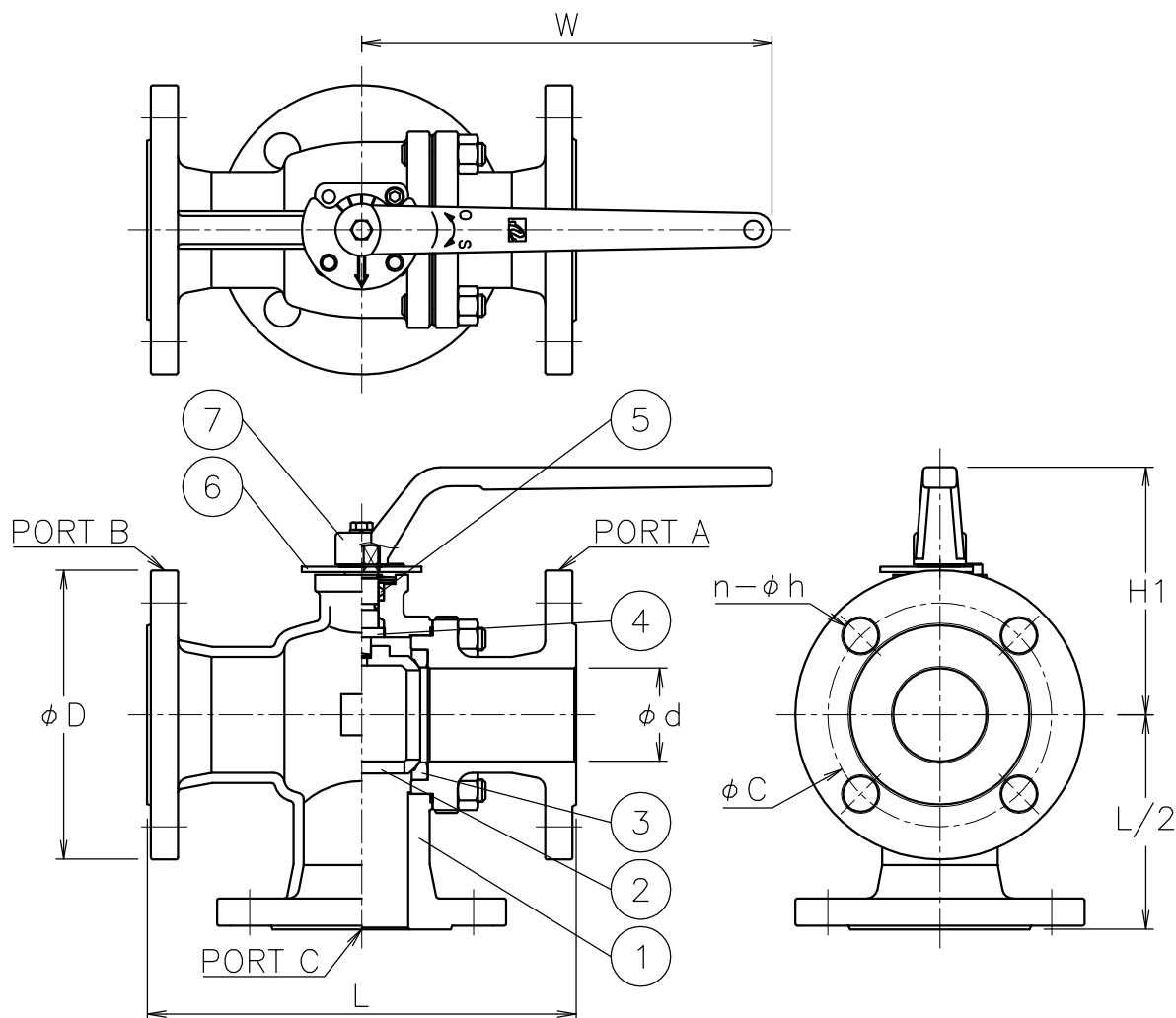

NOTE

(a) Lever handle is removed and shipped.

Flow paths

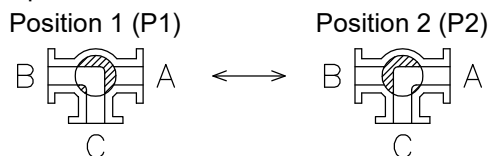

7	Lever handle	SCS13A	1	(a)
6	Position indicator	SUS304	1	
5	Packing	R-PTFE	1set	
4	Stem	SUS304	1	
3	Seat	R-PTFE	2	
2	Ball	SUS304/SCS14A	1	
1	Body	SCS13A	1	
No	DESCRIPTION	MATERIALS	REQ'D	REMARKS

			APPR'D	H.F	TITLE	J10K Flanged-end TR type 3 way ball valve					
			CHK'D	K.Y							
			DESIGN		MODEL	MAXTRL-1TTP					
			DRAWN	S.O							
MARK	DATE	BY	DATE	'17-07-03	SCALE	NON	DWG No.	TR-1TTP-L-MA9-EN			
REVISIONS			 NIPPON VALVE CONTROLS, INC.								
MV-2622											