

| Valve DN | S | d | L | H1 | H | Weight (kg) | Cv ON/OFF | Actuator | | Sizing code |
|----------|--------|------|------|----|-----|-------------|-----------|----------|---------|-------------|
| 15 A | Rc 1/2 | 8.5 | 58.2 | 29 | 147 | 1.2 | 3 | AM1-030 | AM2-030 | 0 |
| 20 A | Rc 3/4 | 11.5 | 60 | 32 | 149 | 1.3 | 6 | AM1-030 | AM2-030 | 0 |
| 25 A | Rc 1 | 15 | 73.5 | 39 | 152 | 1.5 | 9 | AM1-030 | AM2-030 | 0 |

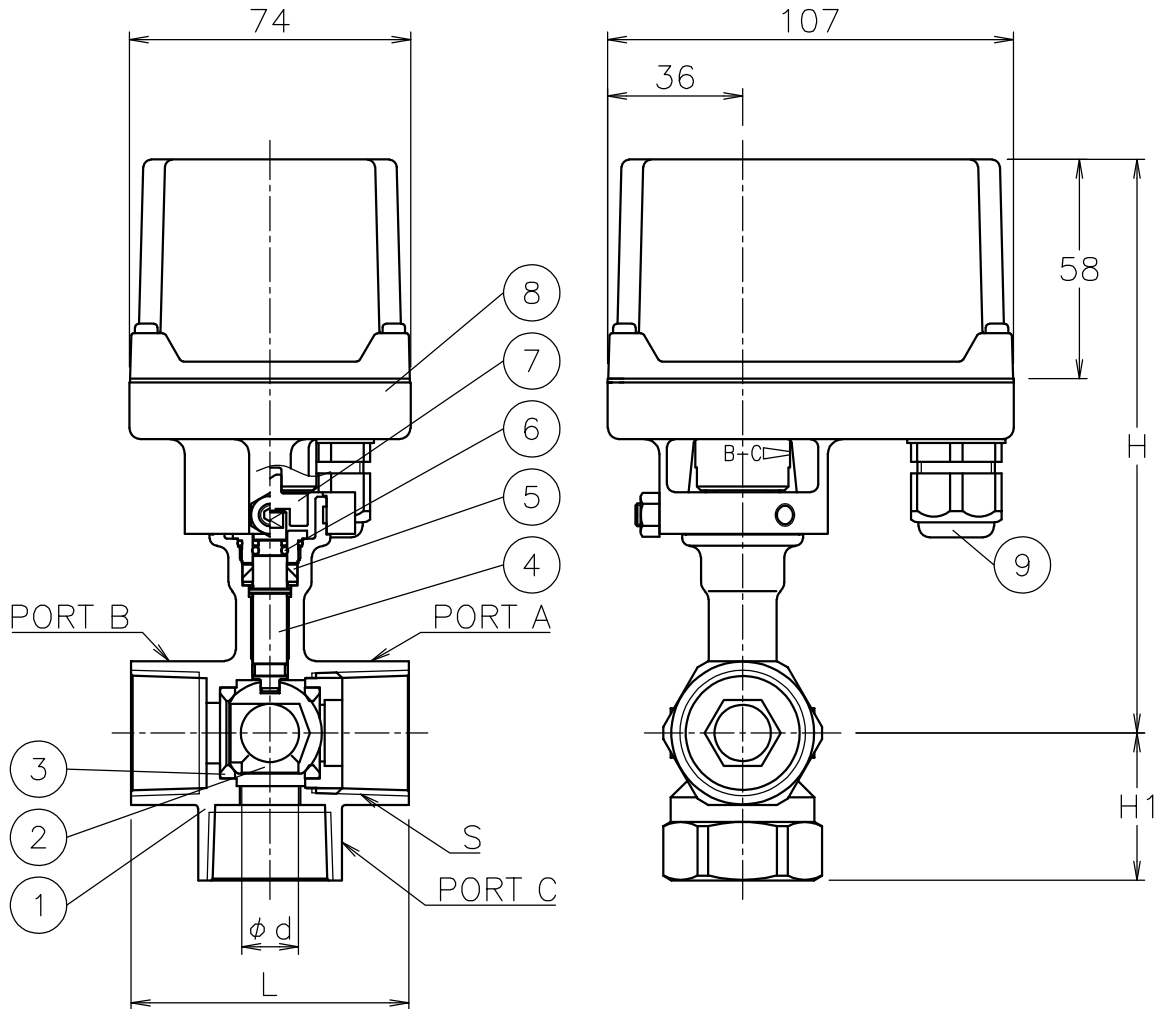

NOTE

(a) Cable acceptance $\phi 5 \sim 10.5\text{mm}$

Flow paths

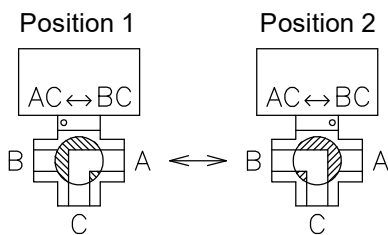

| 9 | Cable gland | NYLON 6 | 1 | G 3/8 (a) |
|----|-------------|----------------|-------|-----------|
| 8 | Actuator | ADC12/PC Cover | 1 | |
| 7 | Joint | SUS304 | 1 | |
| 6 | O-ring | FKM | 1 | |
| 5 | Packing | PTFE | 1 | |
| 4 | Stem | SUS304 | 1 | |
| 3 | Seat | R-PTFE | 2 | |
| 2 | Ball | SUS304 | 1 | |
| 1 | Body | SCS13A | 1 | |
| No | DESCRIPTION | MATERIALS | REQ'D | REMARKS |

| | | | | | | | | | | | |
|-----------|------|----|--------|-----------|-------|------------------------------------|---------|------------------|--|--|--|
| | | | APPR'D | H.F | TITLE | Threaded End Rc Valve DN: 15~25 A | | | | | |
| | | | CHK'D | K.Y | | TE type motorized 3 way ball valve | | | | | |
| | | | DESIGN | | MODEL | AM1TE*05TTP AM2TE*05TTP | | | | | |
| | | | DRAWN | P.O | | | | | | | |
| MARK | DATE | BY | DATE | '16-04-08 | SCALE | NON | DWG No. | TE-05TTP-AM2a-EN | | | |
| REVISIONS | | | | | | | | | | | |
| MV-2167 | | | | | | | | | | | |



NIPPON VALVE CONTROLS, INC.