

Valve DN	S	d	L	H1	H	Weight (kg)	Cv ON/OFF	Actuator	Sizing code
15 A	Rc 1/2	8.5	58.2	29	174	1.2	3	ACR-030	0
20 A	Rc 3/4	11.5	60	32	176	1.3	6	ACR-030	0
25 A	Rc 1	15	73.5	39	179	1.5	9	ACR-030	0

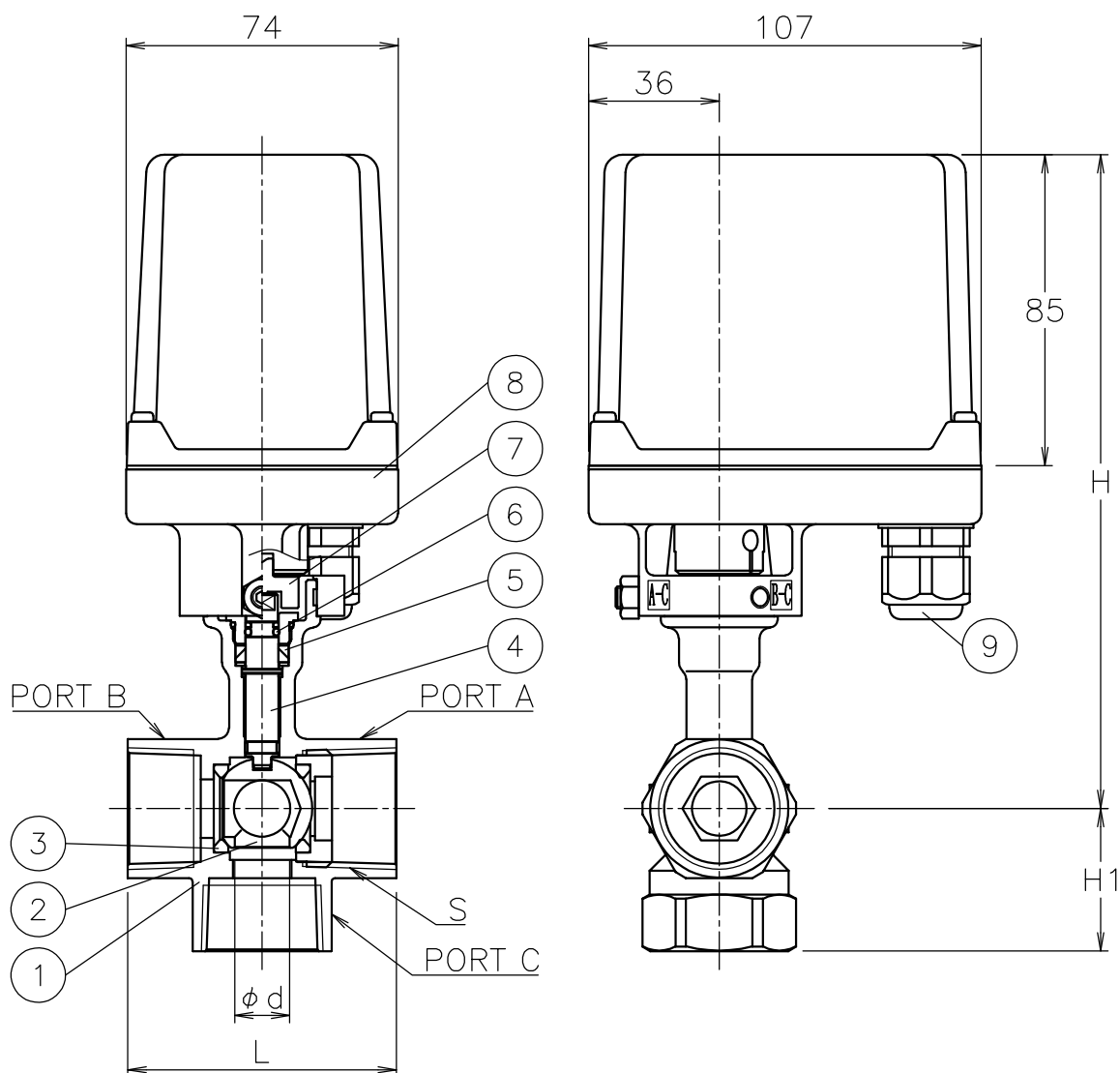

NOTE

(a) Cable acceptance $\phi 5 \sim 10.5\text{mm}$

Flow paths

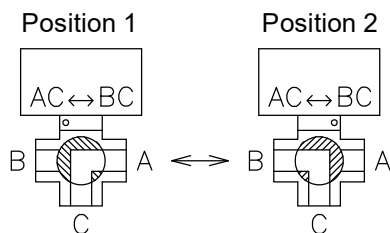

9	Cable gland	NYLON 6	1	G 3/8 (a)
8	Actuator	ADC12/PC Cover	1	
7	Joint	SUS304	1	
6	O-ring	FKM	1	
5	Packing	PTFE	1	
4	Stem	SUS304	1	
3	Seat	R-PTFE	2	
2	Ball	SUS304	1	
1	Body	SCS13A	1	
No	DESCRIPTION	MATERIALS	REQ'D	REMARKS

			APPR'D	H.F	TITLE	Threaded End Rc Valve DN: 15~25 A			
			CHK'D	K.Y		TE type electric emergency shut off 3 way ball valve			
			DESIGN		MODEL	ACRTE205TTP			
			DRAWN	P.O					
MARK	DATE	BY	DATE	'16-04-19	SCALE	NON	DWG No.	TE-05TTP-AC2a-EN	
REVISIONS			 NIPPON VALVE CONTROLS, INC.						
MV-2167									