

Valve DN	S	d	L	W	W1	N	N1	H	Weight (kg)	Cv () : straight port	Actuator		Sizing code
15 A	Rc 1/2	13	75	249	55	92	46	161	3.1	4 (7)	TAO-040	TAC-040	0
20 A	Rc 3/4	16	85	249	55	92	46	164	3.5	8 (13)	TAO-040	TAC-040	0
				305	85	103	50	202	4.3		TAO-050	TAC-050	2
25 A	Rc 1	20	100	305	85	103	50	173	4.7	14 (22)	TAO-050	TAC-050	0
32 A	Rc 1 1/4	25	115	305	85	103	50	178	5.5	22 (33)	TAO-050	TAC-050	0
				367	102	119	52	227	7.6		TAO-063	TAC-063	2

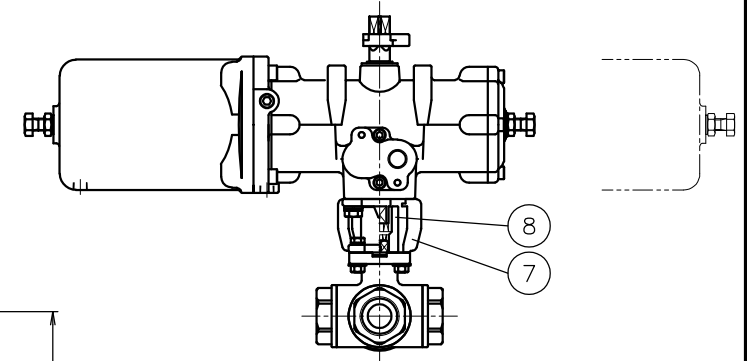

TA*ST925UUUF-020
TA*ST925UUUF-032

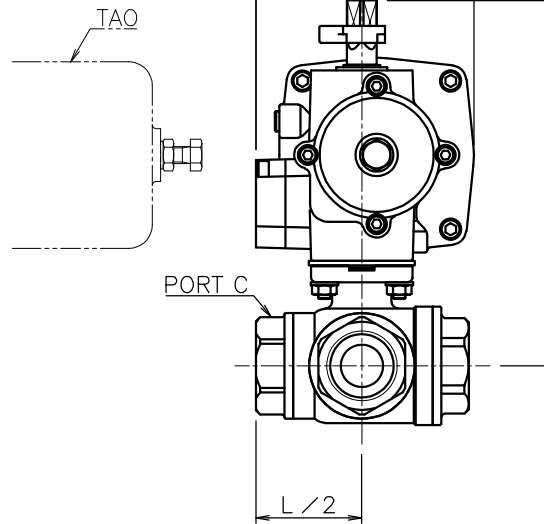
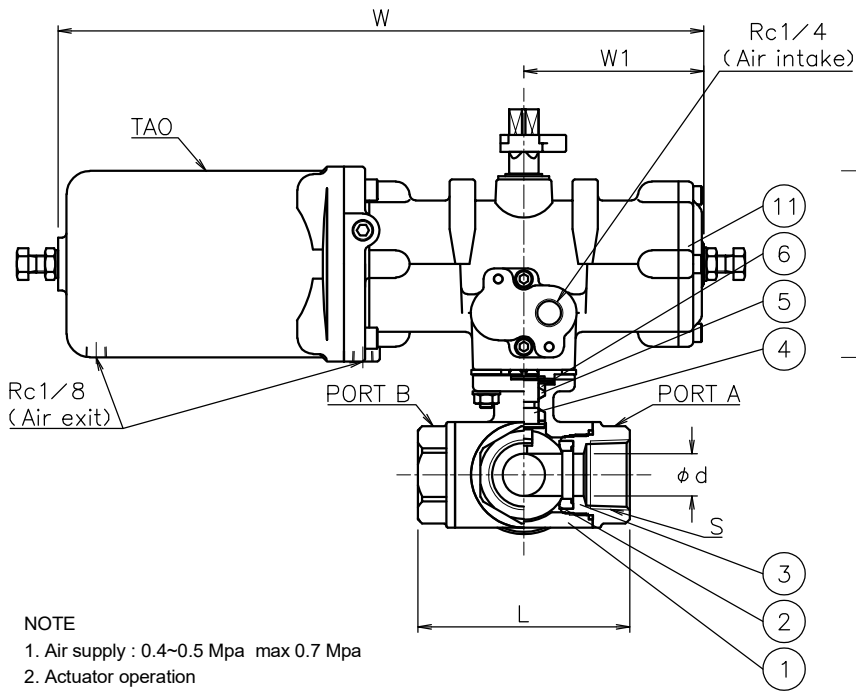
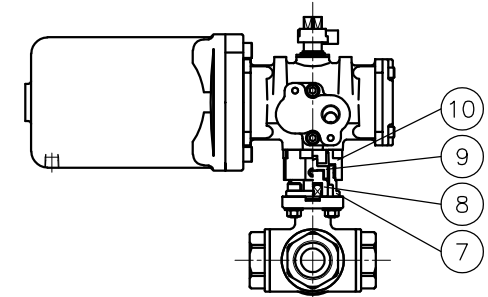

TA*ST905UUUF-015
TA*ST905UUUF-020

NOTE

1. Air supply : 0.4~0.5 Mpa max 0.7 Mpa

2. Actuator operation

TAO serie • Air to intake port : Position 2

• Spring return : Position 1

TAC serie • Air to intake port : Position 1

• Spring return : Position 2

※ This drawing is TAO.

※ Only as for TAC-040,

a cylinder direction becomes the same as TAO.

Flow paths (Top view of valve)

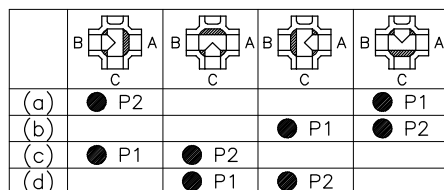

4 type : (a) ~ (d)

No	DESCRIPTION	MATERIALS	REQ'D	REMARKS
11	Actuator		1	TAO/C
10	Bracket	ZDC2	1	
9	Joint	SUS304	1	
8	Joint	SCS13A	1	
7	Bracket	SCS13A	1	
6	Packing	R-PTFE	1	
5	Packing	F-PTFE	1	
4	Stem	SUS316	1	
3	Seat	F-PTFE	4	
2	Ball	SCS14A	1	
1	Body	SCS14A	1	

MARK	DATE	BY	APPR'D	H.F	TITLE	MODEL	SCALE	NON	DWG No.	REMARKS
			CHK'D	K.Y	Threaded End Rc (single-acting type) ST type pneumatic actuated 3 way ball valve	TAOST9*5UUF				Valve DN: 15~32 A
			DESIGN			TACST9*5UUF				
			DRAWN	P.O						
			DATE	'16-05-17						ST-9*5UUF-TD3-EN
REVISIONS										
MV-2500										