

Valve DN	S	d	L	H	Weight (kg)	Actuator	Sizing code
15 A	Rc 1/2	16	75	204	2.9	ECR-120	0
20 A	Rc 3/4	20	80	208	3	ECR-120	0
25 A	Rc 1	25	88	213	3.3	ECR-120	0
32 A	Rc1 1/4	32	110	218	3.8	ECR-120	0
40 A	Rc1 1/2	38	120	227	5.1	ECR-360	0

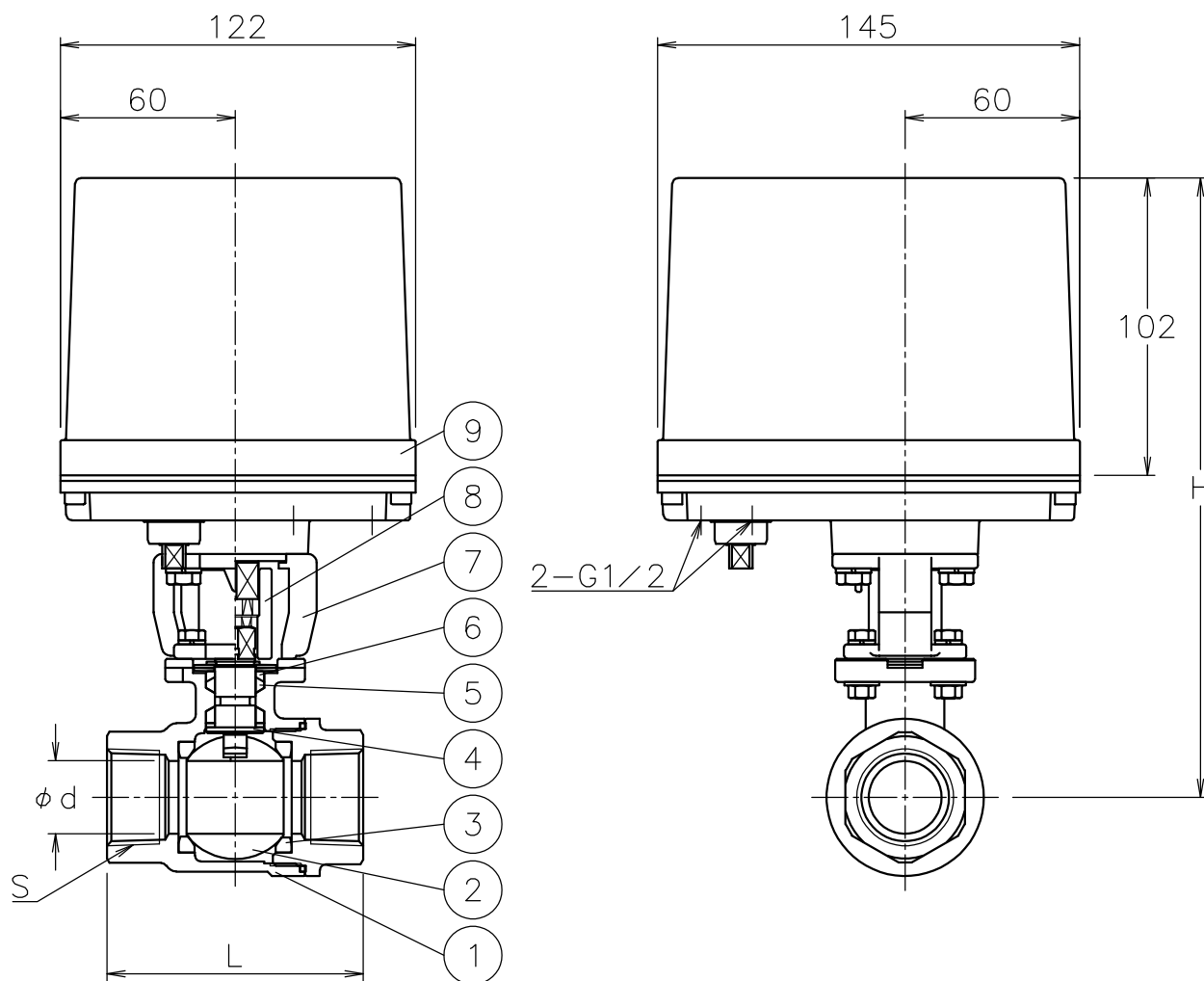

NOTE

Attachment

- Cable gland (nylon), G1/2, for φ6~12 cable
- Plug

9	Actuator	Aluminum alloy die-cast cover	1	
8	Joint	SUS304	1	
7	Bracket	SCS13A	1	
6	Packing	R-PTFE	1	
5	Packing	F-PTFE	1	
4	Stem	SUS316	1	
3	Seat	PTFE	2	
2	Ball	SCS14A	1	
1	Body	SCS14A	1	
No	DESCRIPTION	MATERIALS	REQ'D	REMARKS

			APPR'D	H.F	TITLE	Threaded End Rc Valve DN: 15~40 A		
			CHK'D	K.Y		SR type electric emergency shut off ball valve		
			DESIGN		MODEL	ECRSR*05UUT		
			DRAWN	P.O				
MARK	DATE	BY	DATE	'16-04-01	SCALE	NON	DWG No.	SR-05UUT-EC3-EN
REVISIONS			 NIPPON VALVE CONTROLS, INC.					
MV-2500								