

Valve DN	S	d	L	W	N	N1	H	Weight (kg)	Cv	Actuator		Sizing code
15 A	Rc 1/2	13	75	185	68	36	129	1.3	5	PSO-04D	PSC-04D	0
20 A	Rc 3/4	16	85	185	68	36	133	1.7	10	PSO-04D	PSC-04D	0
25 A	Rc 1	20	100	247	82	44	145	2.9	16	PSO-05D	PSC-05D	0
32 A	Rc1 1/4	25	115	247	82	44	151	3.6	25	PSO-05D	PSC-05D	0
				288	95	48	151	4.2		PSO-05W	PSC-05W	2

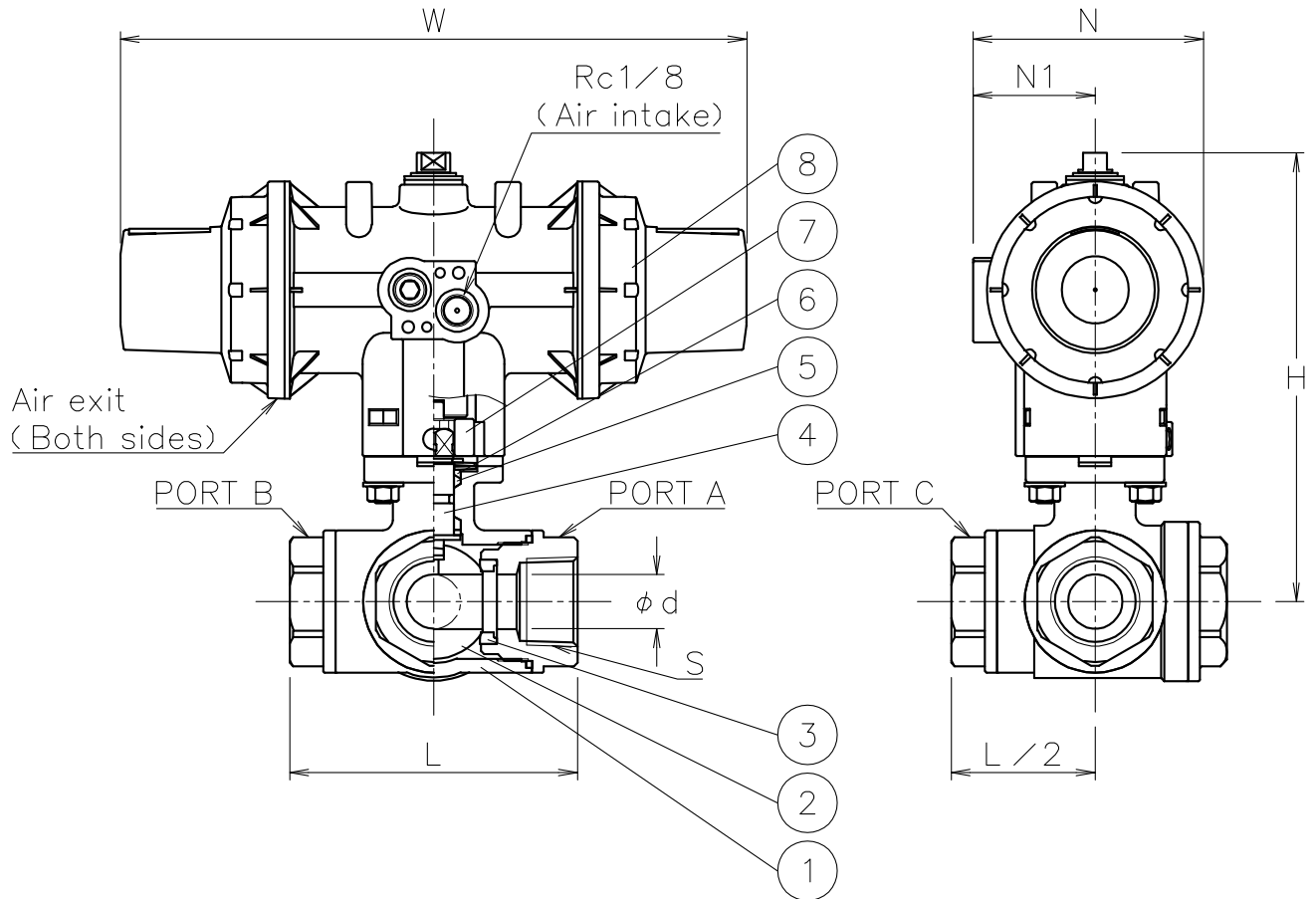

NOTE

- Air supply : 0.4~0.5 Mpa max 0.7 Mpa
- Actuator operation
 - PSO serie
 - Air to intake port : Position 2
 - Spring return : Position 1
 - PSC serie
 - Air to intake port : Position 1
 - Spring return : Position 2
- Coupling OD must be less than $\phi 14.5$

Flow paths (Top view of valve)

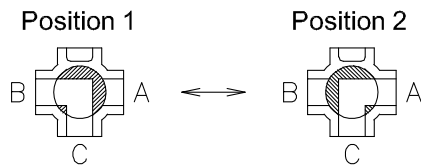

8	Actuator	PPS body	1	PSO/C
7	Joint	SUS304	1	
6	Packing	R-PTFE	1	
5	Packing	F-PTFE	1	
4	Stem	SUS316	1	
3	Seat	F-PTFE	4	
2	Ball	SCS14A	1	
1	Body	SCS14A	1	
No	DESCRIPTION	MATERIALS	REQ'D	REMARKS

			APPR'D	K.Y	TITLE	Valve DN: 15~32 A					
			CHK'D	K.Y		Threaded End Rc (single-acting type)					
			DESIGN			SL type pneumatic actuated 3 way ball valve					
			DRAWN	T.A	MODEL	PSOSL9*5UUF		PSCSL9*5UUF			
MARK	DATE	BY	DATE	'22-12-09	SCALE	NON	DWG No.	SL-9*5UUF-DA1-EN			
REVISIONS			NIPPON VALVE CONTROLS, INC.								
MV-2987											