

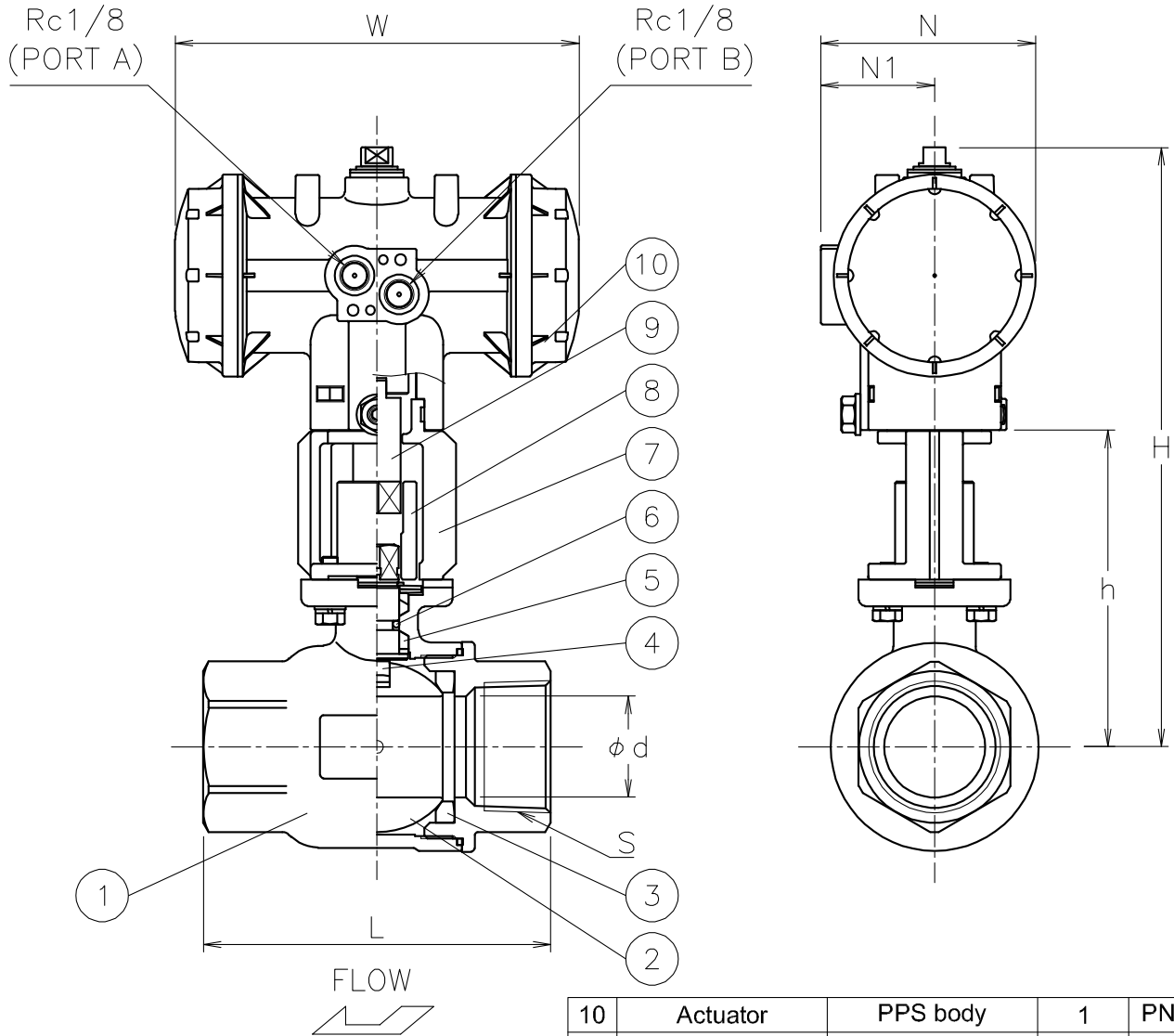

Size [mm]	S	d	L	H1	W	N	N1	H	Weight (kg)	Actuator	Sizing code
15	Rc 1/2	16	75	87	108	57	30	160	0.9	PND-03D	0
20	Rc 3/4	20	80	90	108	57	30	163	1.1	PND-03D	0
25	Rc 1	25	88	95	128	68	36	185	1.6	PND-04D	0
32	Rc1 1/4	32	110	101	128	68	36	190	2.1	PND-04D	0



NOTE

- 1) Air supply: 0.4 to 0.5 Mpa. Max 0.7 Mpa.
- 2) Actuator operation
Air to port A: SHUT.
Air to port B: OPEN.
- (a) Coupling OD must be less than 14.5 mm.

10	Actuator	PPS body	1	PND (a)
9	Joint	SUS304	1	
8	Joint	SUS304	1	
7	Bracket	SCS13A	1	
6	O-ring	Steam resistant FKM	1	
5	Packing	R-PTFE	1	
4	Stem	SUS316	1	
3	Seat	F-PTFE	2	
2	Ball	SCS14A	1	
1	Body	SCS14A	1	
No	DESCRIPTION	MATERIALS	REQ'D	REMARKS

			APPR'D	K.Y	TITLE	Threaded End Rc (double-acting type) SH type pneumatic actuated ball valve					
			CHK'D	K.Y							
			DESIGN		MODEL	PNDSH905UUF					
			DRAWN	T.A							
MARK	DATE	BY	DATE	'22-12-09	SCALE	NON	DWG No.	SH-905UUF-NA1-EN			
REVISIONS			 NIPPON VALVE CONTROLS, INC.								
MV-2987											