

Valve DN	S	d	L	H1	H	Weight (kg)	Actuator		Sizing code
15 A	Rc 1/2	16	75	111	240	3.1	AE1-120	AE2-120	0
20 A	Rc 3/4	20	80	115	244	3.2	AE1-120	AE2-120	0
25 A	Rc 1	25	88	120	249	3.6	AE1-120	AE2-120	0
32 A	Rc1 1/4	32	110	125	254	4.7	AE1-360	AE2-360	0

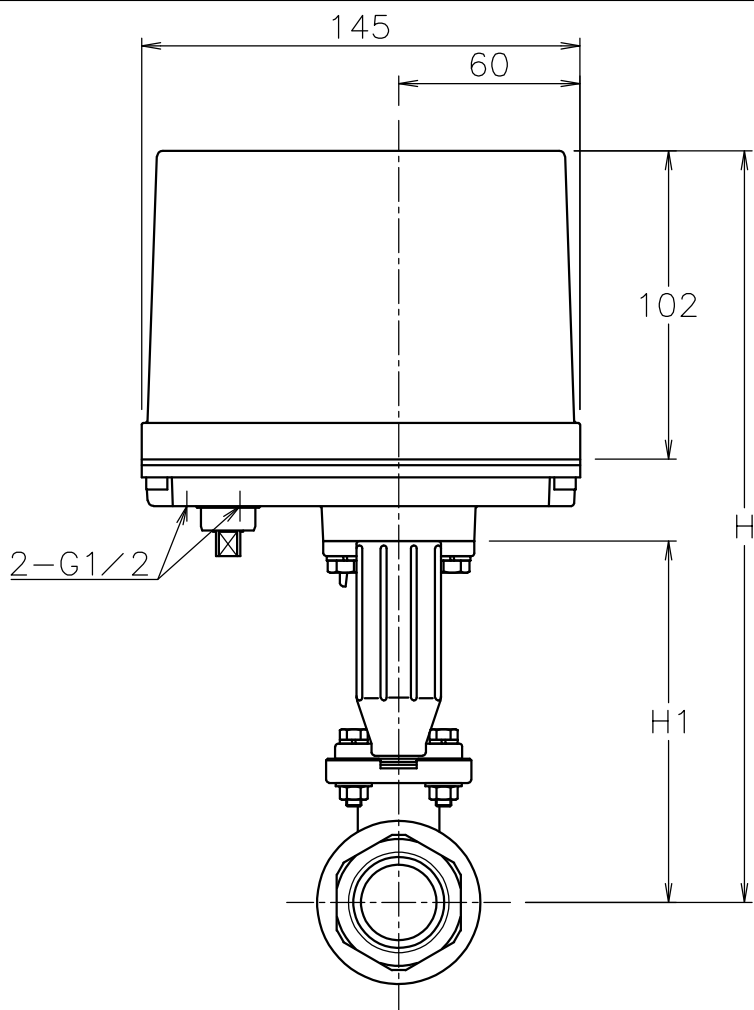
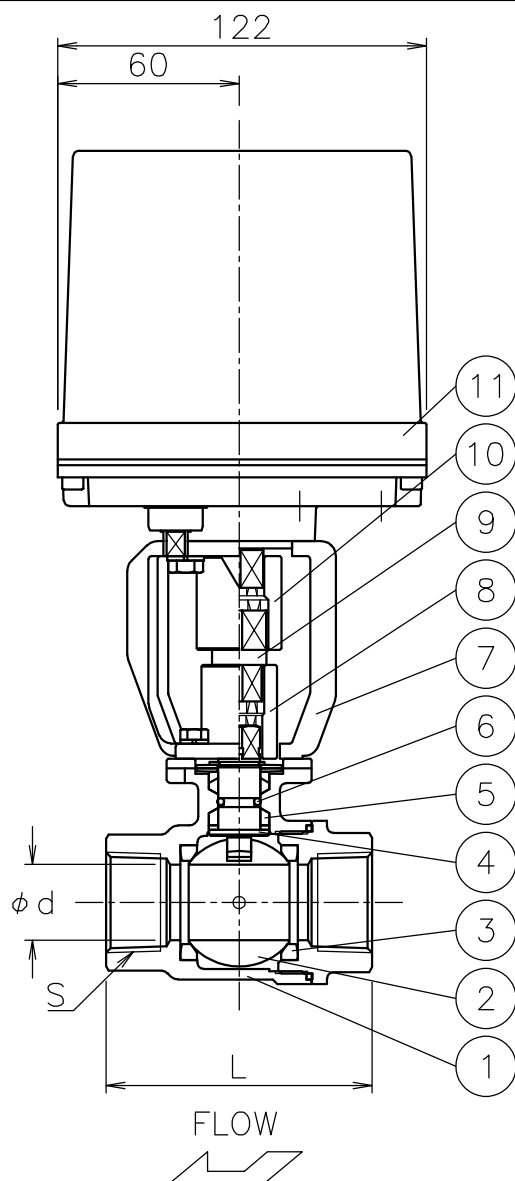

NOTE

Attachment

- Cable gland (nylon), G1/2, for $\phi 6 \sim 12$ cable
- Plug

11	Actuator	Aluminum alloy die-cast cover	1	
10	Joint	SUS304	1	
9	Joint	SUS304	1	
8	Joint	SUS304	1	
7	Bracket	SCS13A	1	
6	O-ring	Steam resistant FKM	1	
5	Packing	R-PTFE	1	
4	Stem	SUS316	1	
3	Seat	F-PTFE	2	
2	Ball	SCS14A	1	
1	Body	SCS14A	1	
No	DESCRIPTION	MATERIALS	REQ'D	REMARKS

			APPR'D	H.F	TITLE	Threaded End Rc Valve DN: 15~32 A SH type electric actuated ball valve				
			CHK'D	K.Y		MODEL	AE1SH*05UUF AE2SH*05UUF			
			DESIGN		SCALE		NON	DWG No.	SH-05UUF-AE3-EN	
			DRAWN	P.O						
MARK	DATE	BY	DATE	'16-04-01						
REVISIONS			 NIPPON VALVE CONTROLS, INC.							
MV-2500										