

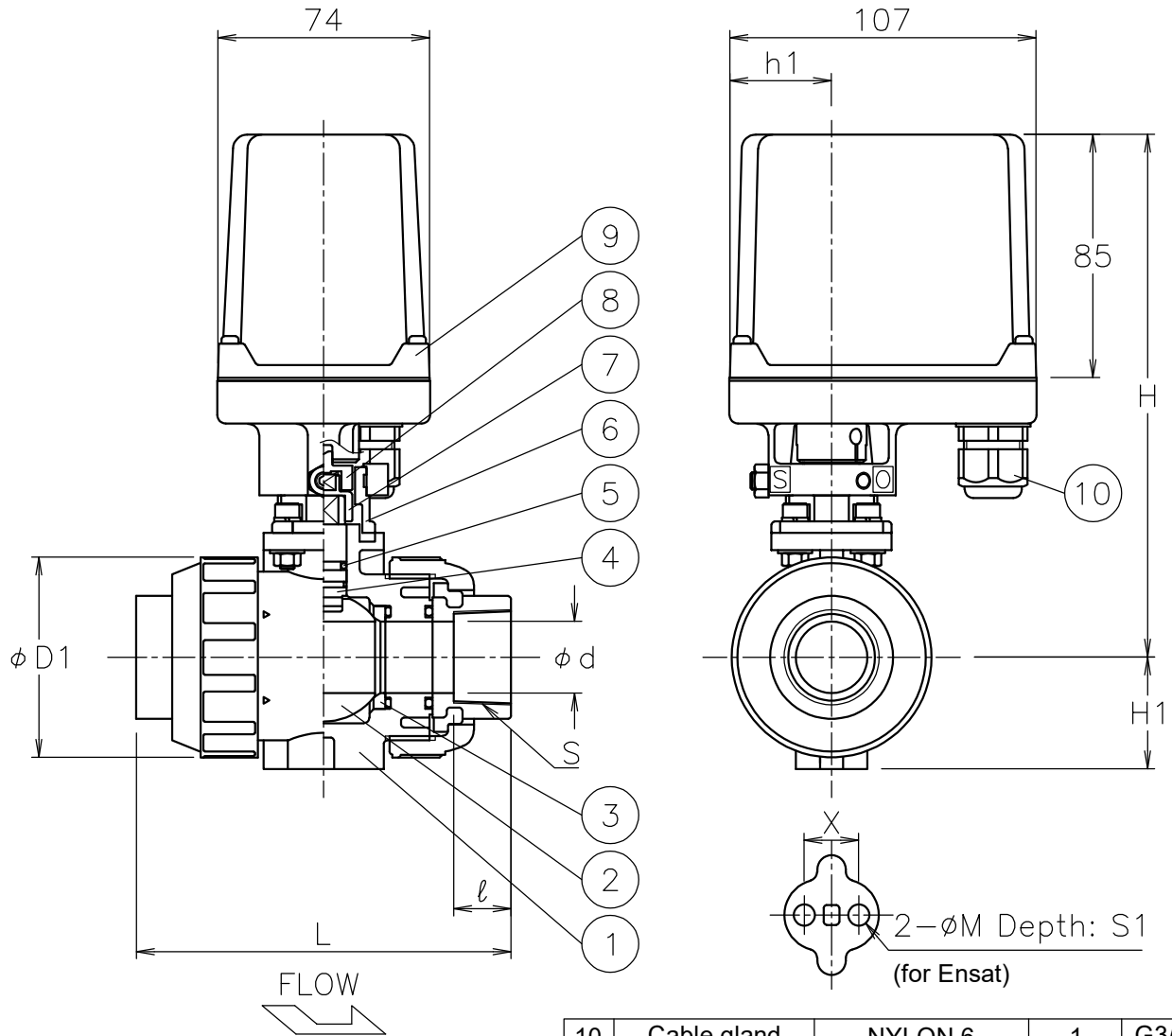

Size [mm]	S	d	D1	ℓ	L	H1	X	M	S1	h1	H	Weight [kg]	Cv	Actuator	Sizing code
15	Rc 1/2	15	48	15	102	29	19	7.3	11	36	170	1.4	14	AH1-030	0
20	Rc 3/4	20	60	17	120	35	19	7.3	11	36	176	1.7	29	AH1-070	0
25	Rc 1	25	70	20	131	39	19	7.3	11	36	183	1.8	47	AH1-070	0
32	Rc1 1/4	32	82	22	150	47	30	9	15	36	200	2.2	72	AH1-070	0
40	Rc1 1/2	40	100	25	163	55	30	9	15	53	234	3	155	AH1-180	0



**NOTE**

(a) Cable acceptance 5φ to 10.5φ mm.

10	Cable gland	NYLON 6	1	G3/8 (a)
9	Actuator	ADC12/PC Cover	1	
8	Joint	SUS304	1	
7	Joint	SCS13A	1	
6	Bracket	SCS13A	1	
5	O-ring	FKM	2	
4	Stem	PVC	1	
3	Seat	PTFE	2	
2	Ball	PVC	1	
1	Body	PVC	1	
No	DESCRIPTION	MATERIALS	REQ'D	REMARKS

			APPR'D	H.F	TITLE	J10K Flanged-end PA type motorized ball valve				
			CHK'D	K.Y						
			DESIGN		MODEL	AH1PA*05PPV				
			DRAWN	S.O						
MARK	DATE	BY	DATE	'21-12-23	SCALE	NON	DWG No.	PA-05PPV-CM4-EN		
REVISIONS			 <b>NIPPON VALVE CONTROLS, INC.</b>							
MV-2947										