

Size [mm]	d	L	t	D	C	n-h	H1	X	M	S1	W1	W2	W3	W4	W5	H	Weight [kg]	Cv	Actuator		Sizing code
15	15	143	12	95	70	4-15	29	19	7.3	11	90	46	76	39	44.5	110	1	14	CM1-030	CM2-030	0
20	20	172	14	100	75	4-15	35	19	7.3	11	105	55	96	48	61	137	1.5	29	CM1-070	CM2-070	0
25	25	187	14	125	90	4-19	39	19	7.3	11	105	55	96	48	61	144	1.7	47	CM1-070	CM2-070	0
32	32	190	16	135	100	4-19	47	30	9	15	105	55	96	48	61	161	2.2	72	CM1-070	CM2-070	0

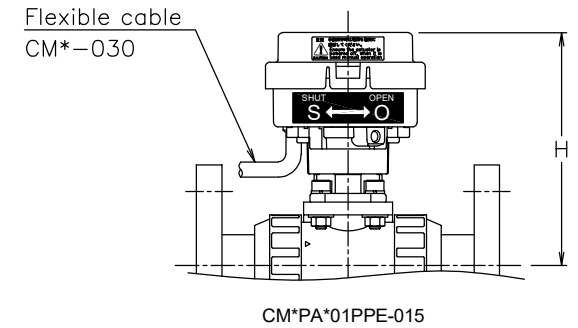
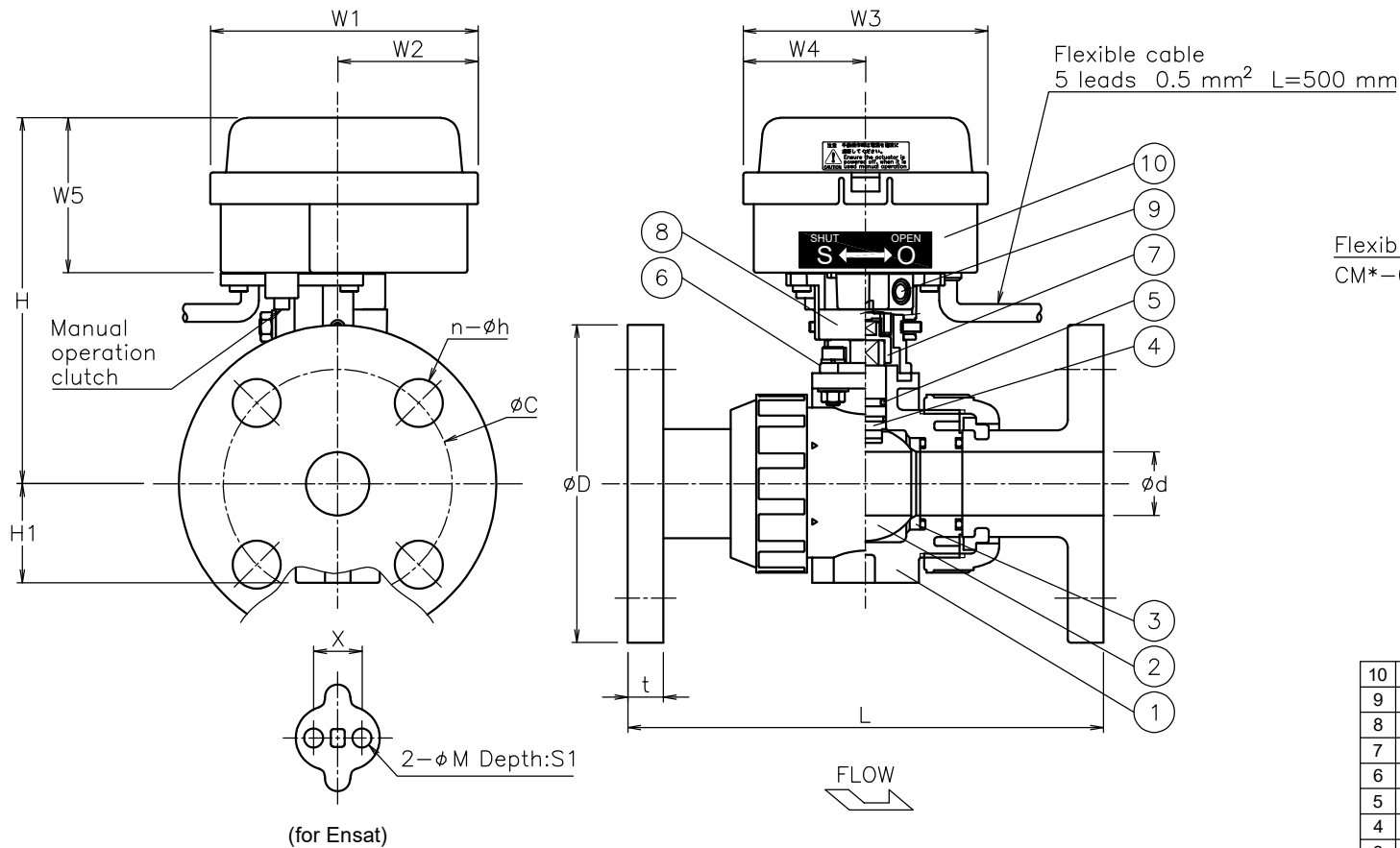

No	DESCRIPTION	MATERIALS	REQ'D	REMARKS
10	Actuator	PC Case	1	
9	Joint	PPS	1	
8	Bracket	PPS	1	
7	Joint	SCS13A	1	
6	Bracket	SCS13A	1	
5	O-ring	EPDM	2	
4	Stem	PVC	1	
3	Seat	PTFE	2	
2	Ball	PVC	1	
1	Body	PVC	1	

NOTE

For manual operation on CM*-070, press the clutch button while operating it.

MARK	DATE	BY	DATE	APPR'D	H.F	TITLE	J10K Flanged-end PA type motorized ball valve				
				CHK'D	K.Y						
				DESIGN							
				DRAWN	S.O	MODEL	CM1PA*01PPE CM2PA*01PPE				
						SCALE	NON	DWG No.	PA-01PPE-CD4-EN		
REVISIONS											
MV-2969											