

NOTE
(a) Heat-resistant PVC

- 1) Air supply: 0.4 to 0.5 Mpa. Max 0.7 Mpa.
- 2) Actuator operation

	Air to intake port	Spring return
TAO	OPEN	SHUT
TAC	SHUT	OPEN

* This drawing is TAO.
* Only TAC-040 has the same cylinder direction as TAO.

Size [mm]	d	L	t	D	C	n-h	H1	X	M	S1	W	W1	N	N1	H	Weight [kg]	Cv	Actuator	Sizing code
15	15	143	12	95	70	4-15	29	19	7.3	11	249	55	92	46	153	3	14	TA*-040	0
20	20	172	14	100	75	4-15	35	19	7.3	11	249	55	92	46	160	3.3	29	TA*-040	0
											305	85	103	50	196	4.1		TA*-050	2
25	25	187	14	125	90	4-19	39	19	7.3	11	249	55	92	46	167	3.5	47	TA*-040	0
32	32	190	16	135	100	4-19	47	30	9	15	249	55	92	46	184	4	72	TA*-040	0
40	40	212	16	140	105	4-19	55	30	9	15	305	85	103	50	220	5.2	155	TA*-050	0
50	51	234	16	155	120	4-19	66	30	9	15	305	85	103	50	232	6.1	190	TA*-050	0
											367	102	119	52	247	8		TA*-063	2
65	65	261	18	175	140	4-19	72	48	9	6	367	102	119	52	267	9	365	TA*-063	0
80	78	306	18	185	150	8-19	85	55	11	7	367	102	119	52	276	11	410	TA*-063	0
											435	120	142	59	318	15		TA*-080	2
100	100	374	18	210	175	8-19	110	65	11	8	435	120	142	59	350	21	680	TA*-080	0

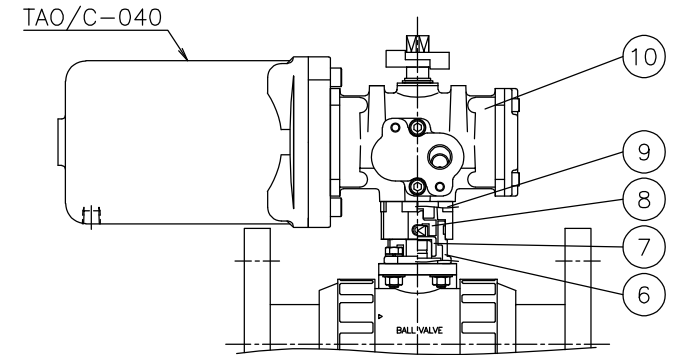
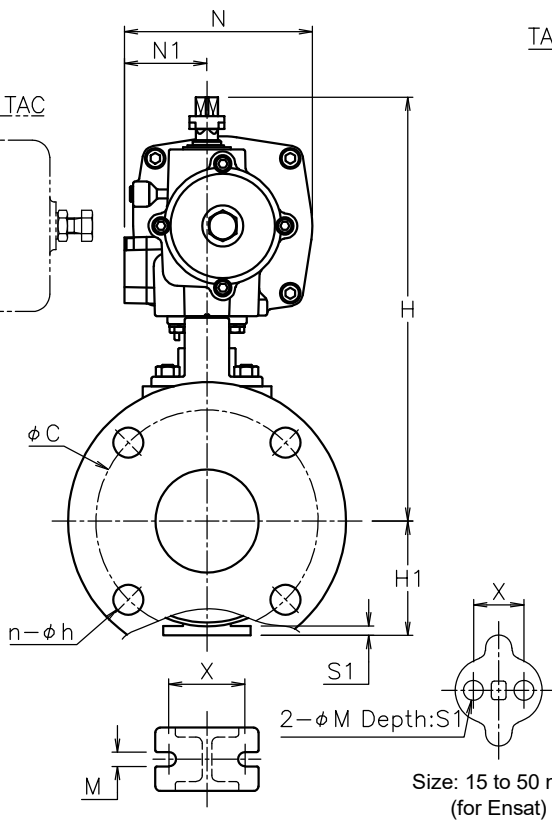
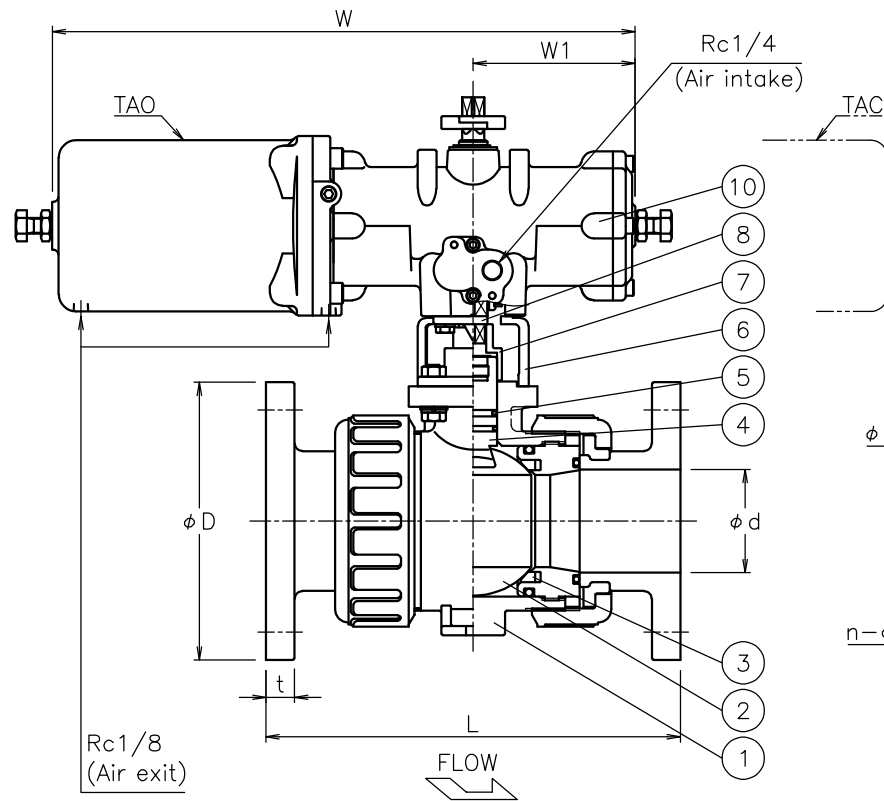

TA*PA901HHV-015
TA*PA901HHV-020
TA*PA901HHV-025
TA*PA901HHV-032

Flow marks are not attached to sizes 65 to 100 mm.

No	DESCRIPTION	MATERIALS	REQ'D	REMARKS
10	Actuator		1	TAO/C
9	Bracket	BERIC	1	
8	Joint	SUS304	1	
7	Joint	SUS303/SCS13A	1	
6	Bracket	SUS304/SCS13A	1	
5	O-ring	FKM	2	
4	Stem	C-PVC	1	(a)
3	Seat	PTFE	2	
2	Ball	C-PVC	1	(a)
1	Body	C-PVC	1	(a)

			APPR'D	K.Y.	TITLE	J10K Flanged-end PA type electric actuated ball valve								
			CHK'D	K.Y.		MODEL	TAOPA9*1HHV TACPA9*1HHV							
			DESIGN		MARK		DATE	BY	DATE	'23-10-25	SCALE	NON	DWG No.	PA-9*1HHV-TD5-EN
			DRAWN	S.O.			REVISIONS							
						MV-3037								