

Size [mm]	d	L	t	D	C	n-h	H1	X	M	S1	h1	h2	H	Weight [kg]	Cv	Actuator	Sizing code
15	15	143	12	95	70	4-15	29	19	7.3	11	36	58	143	1.5	14	AM*-030	0
20	20	172	14	100	75	4-15	35	19	7.3	11	36	58	149	1.8	29	AM*-070	0
25	25	187	14	125	90	4-19	39	19	7.3	11	36	58	156	2	47	AM*-070	0
32	32	190	16	135	100	4-19	47	30	9	15	36	58	173	2.5	72	AM*-070	0
40	40	212	16	140	105	4-19	55	30	9	15	53	85	234	3.5	155	AM*-180	0

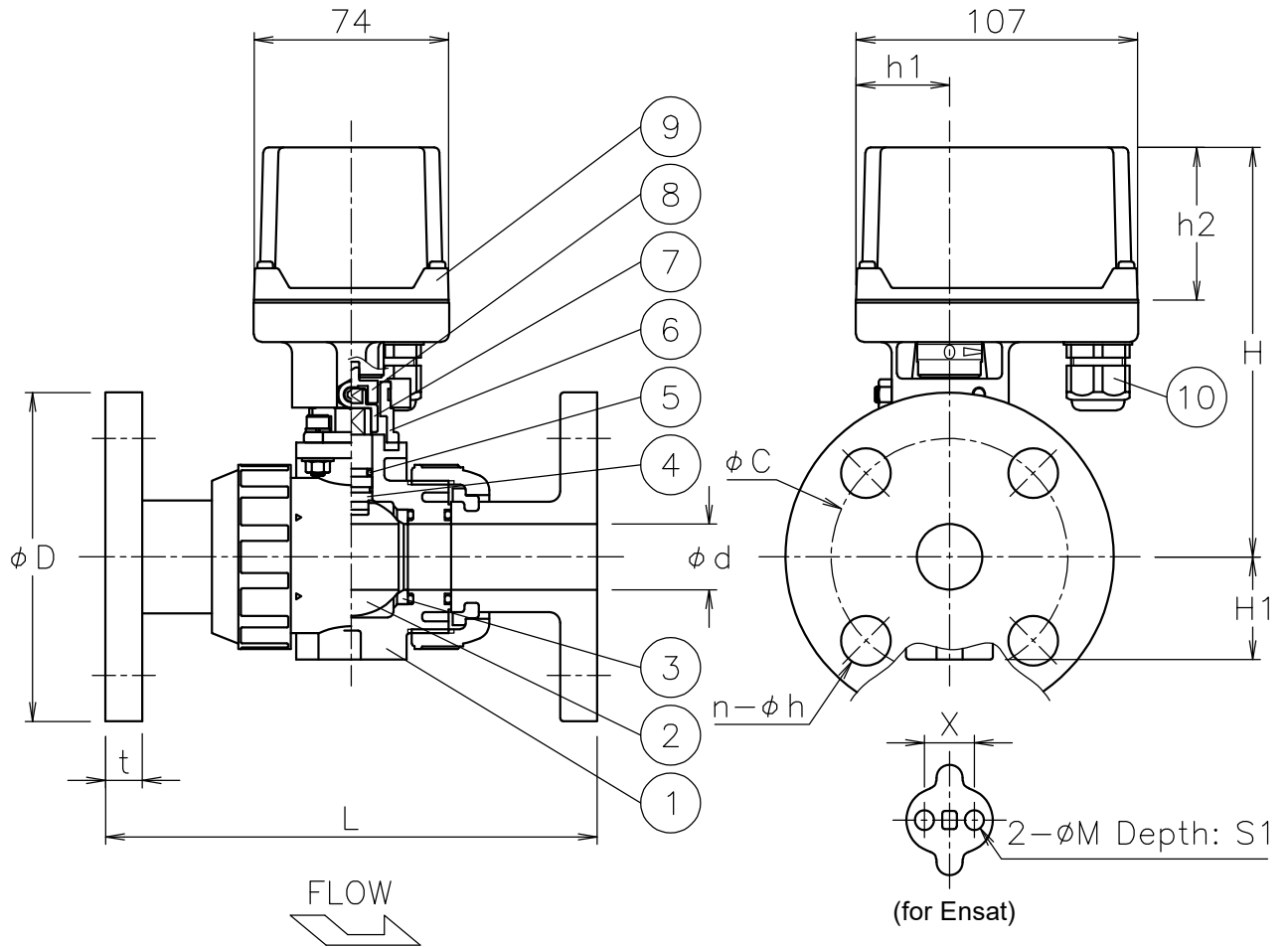

10	Cable gland	NYLON 6	1	G3/8 (b)
9	Actuator	ADC12/PC Cover	1	
8	Joint	SUS304	1	
7	Joint	SCS13A	1	
6	Bracket	SCS13A	1	
5	O-ring	EPDM	2	
4	Stem	C-PVC	1	(a)
3	Seat	PTFE	2	
2	Ball	C-PVC	1	(a)
1	Body	C-PVC	1	(a)
No	DESCRIPTION	MATERIALS	REQ'D	REMARKS

NOTE

(a) Heat-resistant PVC

(b) Cable acceptance 5ϕ to 10.5ϕ mm.

			APPR'D	H.F	TITLE	J10K Flanged-end PA type motorized ball valve			
			CHK'D	K.Y					
			DESIGN		MODEL	AM1PA*01HHE AM2PA*01HHE			
			DRAWN	S.O					
MARK	DATE	BY	DATE	'21-12-17	SCALE	NON	DWG No.	PA-01HHE-AM4-EN	
REVISIONS			 NIPPON VALVE CONTROLS, INC.						
MV-2945									