



Instruction manual

Electric Actuated Butterfly Valve Z

Please read this manual before installation and use.

GENERAL

It is small, light weight and economical butterfly valve.

Actuator

AE1 : For AC power

AE2 : For AC power

Valve

Z type This type designed for 3 piece structure and it is easy to maintenance.

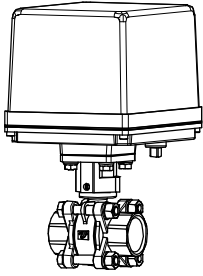

Threaded End Rc

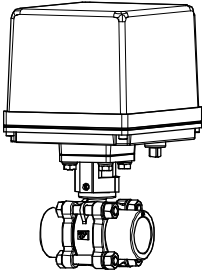

Socket End

PRODUCT CODE

Z type	Threaded End Rc	<input type="text"/>	Z -	<input type="text"/>	<input type="text"/>	5	T	U	<input type="text"/>	-	<input type="text"/>	-	<input type="text"/>
	Socket End	(PVC)	<input type="text"/>	Z -	<input type="text"/>	7	T	P	<input type="text"/>	-	<input type="text"/>	-	<input type="text"/>
		(C-PVC)	<input type="text"/>	Z -	<input type="text"/>	7	T	H	<input type="text"/>	-	<input type="text"/>	-	<input type="text"/>
			(1)	(2)	(3)	(4)	(5)	(6)	(7)	(8)	(9)		(10)

(1) Actuator	(4) Sizing code	(6) Body material	(10) Option
AE1	0 : Standard	T : SCS13A	L0 : Auxiliary limit switch
AE2	1 : Light		L2 : Auxiliary limit switch
	2 : Heavy	(7) Cap material	
(2) Valve		U : SCS14A	
Z-	(5) Connection	(7) Socket material	
	5 : Threaded End Rc	P : PVC	
(3) Voltage	7 : Socket End	H : C-PVC	
1 : 100 / 110 V AC		(8) Seat material	
2 : 200 / 220 V AC		E : EPDM	
		B : NBR	
		V : FKM	
		(9) Size [mm]	
		ex. 25 A → 025	

VALVES SPECIFICATIONS

Water
 Oil
 Air, Gas
 Steam
 Chemicals
 Sea water
 Slurry
 Negative pressure

Valve type	Z		
Design	3 piece structure		
Connection	Threaded End Rc	Socket End	
Fluid			
Max pressure	1 MPa		
Size [mm]	015 to 050		
Material	Body	SCS13A	
	Disc	PPS	
	Cap	SCS14A	-
	Socket	-	PVC C-PVC
	Seat	EPDM NBR FKM	
Stem seal	O-ring	Depend on seat material	

SEAT MATERIAL GUIDE

Seat material	Fluid temp.	Use
EPDM	-20 to +80 °C	
NBR	-10 to +60 °C	
FKM	-0 to +90 °C	

Note) • EPDM seat cannot be used for oil.
 • Unsuitable for steam or hot water over 80 °C.
 • Can flow the seawater with PVC socket and EPDM sheet.

PRESSURE & TEMPERATURE RATING

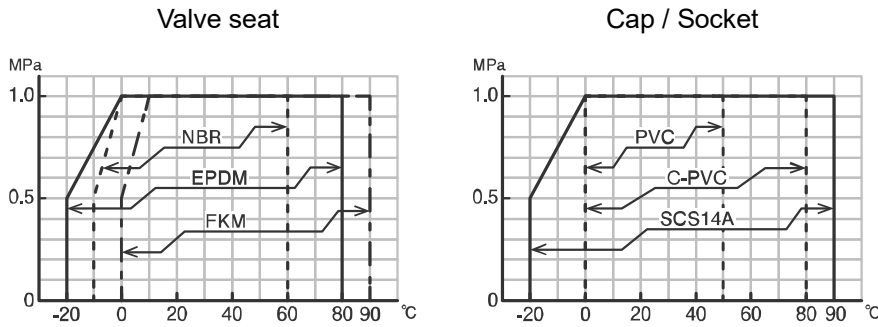

INHERENT FLOW CHARACTERISTIC

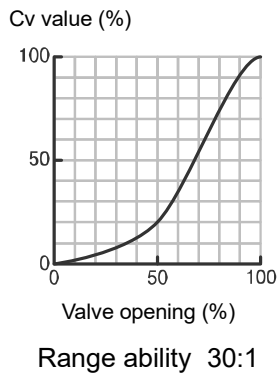

ELECTRIC ACTUATOR SPECIFICATIONS

AE1 type

Actuator type (□:Voltage code)	AE1-120-□	AE1-300-□	AE1-600-□	AE1-02K-□	AE1-06K-□
Voltage	100 / 110 V AC $\pm 10\%$ 50/60 Hz (Code: 1) 200 / 220 V AC $\pm 10\%$ 50/60 Hz (Code: 2)				
Rated torque [N·m]	12	30	60	200	600
Operation time [s]	10 / 8.5 (50/60 Hz)	7.2 / 6 (50/60 Hz)	15 / 12 (50/60 Hz)	30 / 25 (50/60 Hz)	
Power consumption [VA]	19	60		110	350
Motor	Synchronous motor	Reversible motor self-contained mechanical brake			
Overload protection	Thermal protector				
Method of operation	Transfer input type				
Operation	Power to S → SHUT (SHUT PL is lit.) Power to O → OPEN (OPEN PL is lit.)				
Output signal rating	Resistance load 3 A 250 V AC (Minimum 0.1 A)				
Duty cycle	20 % 15 min.				
Ambient temperature	-20 to 55 °C				
Space heater	3 W				
Manual operation	Manual shaft				
Enclosure	Equivalent to IP65 (IEC 60529)				
Housing material	Aluminum alloy diecast (acrylic resin baking finish)				
Wire connection	Terminal Block: M3, Ground terminal: M3				
Conduct port	2-G1/2 Attachments: Cable gland (for $\Phi 6$ to 12 mm cable), plug.				

WIRING

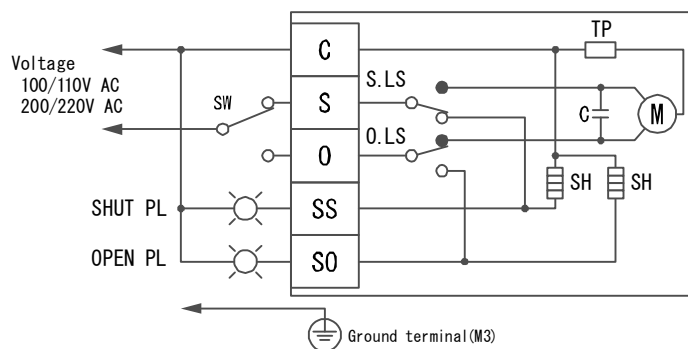

Note) Control switch should be prepared one by one for actuator.
Do not operate two or more actuator from one switch. It might malfunction.

ELECTRIC ACTUATOR SPECIFICATIONS

AE2 type

Actuator type (□:Voltage code)	AE2-120-□	AE2-300-□	AE2-600-□	AE2-02K-□	AE2-06K-□
Voltage	100 / 110 V AC $\pm 10\%$ 50/60 Hz (Code: 1) 200 / 220 V AC $\pm 10\%$ 50/60 Hz (Code: 2)				
Rated torque [N·m]	12	30	60	200	600
Operation time [s]	11 / 9.5 (50/60 Hz)	8.2 / 7 (50/60 Hz)	16 / 13 (50/60 Hz)	31 / 26 (50/60 Hz)	
Power consumption [VA]	26	60		110	350
Motor	Synchronous motor	Reversible motor self-contained mechanical brake			
Overload protection	Timer				
Method of operation	a-contactinput type, with built-in relay				
Operation	SW is OFF → SHUT (SHUT signal is output.) SW is ON → OPEN (OPEN signal is output.) Overtorque → Alarm signal is output				
Input signal current	9 mA (O-terminal) Leakage current in SW: less than 1 mA				
Output signal rating	Resistance load 0.5 A 125 V AC 1 A 24 V DC				
	Micro load 1 mA 5 V DC				
Alarm signal	Output when the motor protection circuit operates by the overload. (it returns by power supply OFF or reverse operating signal)				
Duty cycle	20 % 15 min.				
Ambient temperature	-20 to 55 °C				
Space heater	3 W				
Manual operation	Manual shaft				
Enclosure	Equivalent to IP65 (IEC 60529)				
Housing material	Aluminum alloy diecast (acrylic resin baking finish)				
Wire connection	Terminal Block: M3, Ground terminal: M3				
Conduct port	2-G1/2 Attachments: Cable gland (for $\Phi 6$ to 12 mm cable), plug.				

WIRING

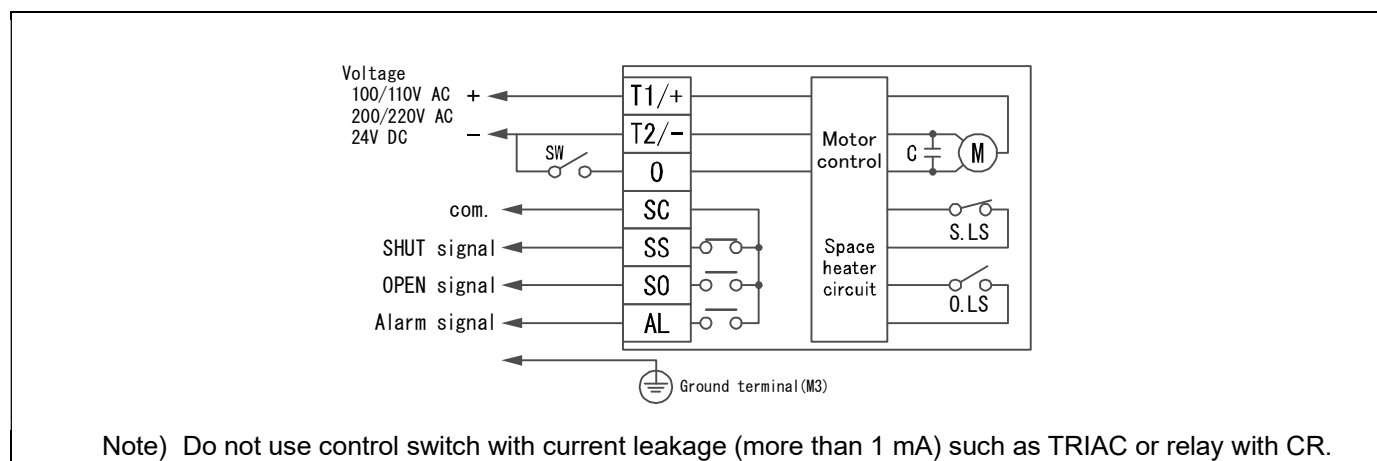

ELECTRIC ACTUATOR SPECIFICATIONS

OPTIONAL PARTS

Specifications	Code No.	AE1	AE2	Remarks	
Auxiliary limit switch	Select limit switch depending on the load	L0	○	○	For standard signal
		L2	○	○	For micro load signal

*Auxiliary limit switch: Please refer to the specifications.

WIRING (OPTION)

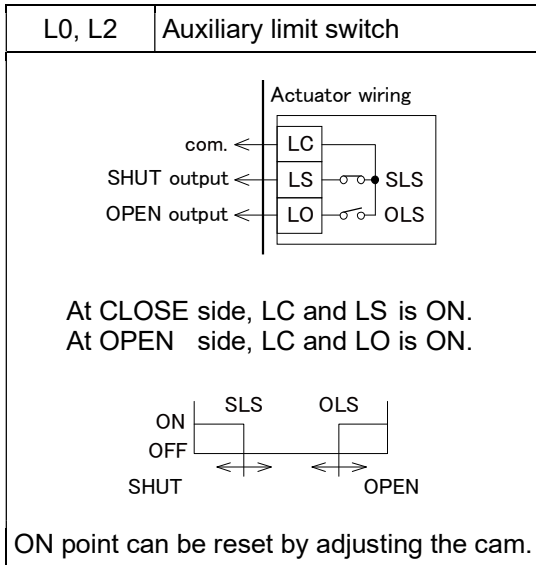

DIMENSIONS

AE

AE-120, 300, 360

AE-600, 700

AE-02K

AE-06K

Parts name

1	Body	5	Terminal block	9	Manual shaft
2	Motor cover	6	Limit switch	10	Rubber packing
3	Motor	7	SW setting cam		
4	Control board	8	Drive shaft		

INSTALLATION, OPERATION & MAINTENANCE INSTRUCTIONS**HANDLING & STORAGE****①HANDLING**

Do not drop or throw the product as it may break.

②STORAGE

- Store away from dust, moisture and direct sunlight. If possible, store in the original package.
- Do not remove a dust proof cap until the piping.

③CHECKING

- Check the product code, power supply, and voltage before installation.
- Make sure that the bolts are not loose.

INSTALLATION**①PRECAUTIONS**

- Flush the pipeline carefully before installing the valve. Foreign particles, such as sand or pieces of welding electrode, will damage the disk and seats.
- When piping the valve disk should be closed before mounting.
- Avoid oil or grease when using EPDM seat.

②PIPING

- Using a pipe with too long a thread will damage the valve.
- If sealing tape or sealant gets inside the valve, the valve seat leaks or malfunctions.
- When connecting a pipe or fitting to a valve, use a tool on the octagonal or hexagonal part of the insertion side and screw it.
- Refer to the recommended tightening torque table and do not apply excessive torque.

Valve size [mm]	Torque [N·m]
015	25 to 35
020	40 to 50
025	50 to 60
032	60 to 80
040	75 to 85
050	90 to 110

③Socket End

Should use adhesive suitable for valve materials.

④ENVIRONMENT

- Do not install in place where corrosive gas is present or where vibration is heavy (0.5 G or more).
- When radiant heat causes the surface temperature of the control unit to exceed 55 °C, provide an appropriate shielding plate.
- If there is a possibility that the fluid and drive part freeze, please take measures to prevent freezing.

⑤POSITIONING

Should be positioned through 90° upward from horizontal. Provide space around the product to allow manual operation, inspection and replacement work.

Maintenance space for upper part of actuator.

AE (120 / 300 / 600)	More than 105 mm
AE (02K / 06K)	More than 120 mm

⑥OTHER NOTES

Until the wiring is completed there must be no condensation or flooding in the interior of the actuator, after piping. Protective caps on the cable gland are not waterproof.

INSTALLATION, OPERATION & MAINTENANCE INSTRUCTIONS**WIRING****①PRECAUTIONS**

- Remove the actuator cover before wiring.
- Two G1/2 electrical connections are provided with a cable gland and plug. Usable cable size is $\Phi 6$ to 12 mm.
- When using a flexible tube, dew condensation may occur inside the actuator due to respiration from the inside of the tube and malfunction may result. Seal the flexible tube connector part with a sealant.
- Sealants that affect the electrical contacts should not be used inside the electric actuator.
- If long distance wiring or low voltage operation, check that terminal voltage is in the proper range.

②CONNECTION

- Do not wiring outdoors on a rainy day.
- Check the power supply and voltage. Connect the signal as shown in the wiring diagram. Do not connect unnecessarily terminal.
- Actuator should be electrically grounded. Use the terminal marked (\oplus) inside the actuator.

PREVENT DEW CONDENSATION

- When installing the cover after wiring, perform the bolt by the temporary tightening procedure and the permanent tightening procedure to tightly and securely tighten the rubber packing so that water does not enter from the outside.
- Tighten the cable gland nut so that there is no leakage from the wire entrance.

CONTROL**①AE1**

Each control switch should be prepared one by one. Do not operate two or more from one switch at the same time.

②AE2

When using control switch with current leakage (more than 1 mA) such as TRIAC or relay with CR, it can cause malfunction.

③USE OF OPEN/SHUT SIGNALS

Use signals within the capacity of output signal rating.

OPERATION**①TESTING**

- Make sure that power supply voltage is correct. Also check operating position, wiring, speed and signals.
- During trial operation, check that valve movement and OPEN and SHUT signals are correct.

②DUTY CYCLE

Confirm that the operation frequency is within the specified duty cycle.

Use beyond the load time rate range will affect product life. Also, it may cause burnout.

Duty cycle is a value that regulates the opening / closing frequency of the actuator. The meaning of 20% 15 minutes for Duty cycle is that 3 minutes (20% of 15 minutes) operation is possible. The calculated value obtained by dividing 3 minutes by the operation time is the number of times of operation within 15 minutes.

③ATTENTION

- Keep power supplied for built-in space heater to prevent condensation inside actuator.
- Do not touch the moving parts of actuator in operation.
- Do not insert a reverse signal during operation. It may shorten the life of product.
- Never put anything on the actuator or make it into a foothold.

INSTALLATION, OPERATION & MAINTENANCE INSTRUCTIONS**MANUAL OPERATION****①PRECAUTIONS**

- Be sure to turn off the power before manual operation.
- Operate manually with reference to the opening degree label. Do not turn beyond the fully open / fully closed position. Operation failure may occur during automatic operation.

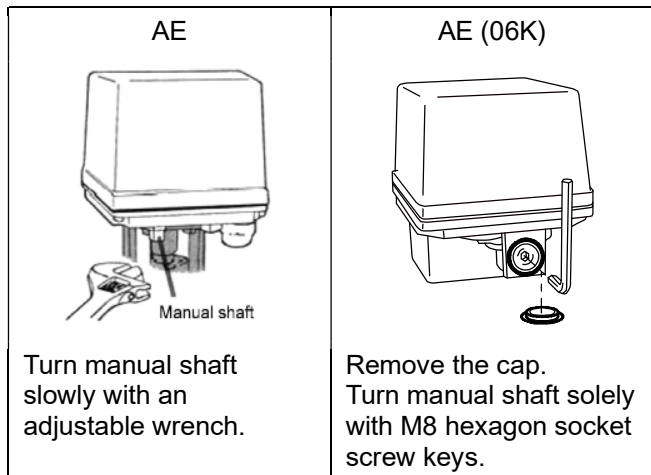
②THE WAY OF OPERATION

Before automatic operation, be sure to remove wrench.

MAINTENANCE

- To prevent electric shock, be sure to turn off the power when removing the actuator cover.
- Do the routine maintenance at least once in half a year.

Inspection items

- Confirm operation of opening and closing.
- Confirm that an actuator is not hot excessively.
- Confirm existence of abnormal noise and vibration during operation.
- Confirm whether screws are loose or not.
- Confirm that water or condensation no remains in the actuator.
- Confirm the fluid temperature or pressure.
- Confirm the leak from valve stem.

INSTALLATION, OPERATION & MAINTENANCE INSTRUCTIONS

TROUBLE SHOOTING

Problem	Cause	Solution
Actuator does not move.	Faulty wiring.	Correct the wiring.
	No voltage is coming.	Check the voltage.
	Incorrect voltage.	When it's burned out by excess voltage, replace the actuator.
	Short the circuit, contact failure.	Review wires and connection.
	Motor is too old.	Replace the actuator. Repair in our factory.
Operation is unstable.	Excess surge or voltage was applied.	<ul style="list-style-type: none"> • Replace the control board or limit switch. (Repair in our factory) • Replace the actuator.
	Rainwater entered the actuator.	<ul style="list-style-type: none"> • Dry the inside. • Replace the actuator.
	Added high harmonics noise from an inverter.	Attachment a filter for each inverter maker option.
	Effect of high level noise.	Use the shielded wire and ground the wiring. Separate signal wire from power line.
	Two or more valves operated by the same switch. AE1	Each control switch should be prepared one by one.
	Switch leakage current is large. AE2	Current leakage should be less than 1 mA.

Problem	Cause	Solution
Stop in the mid position.	There is a foreign object in the butterfly valve.	Remove a foreign object.
	Overload protector runs because of over-torque.	Turn off the power for about 3 minutes to remove a heat from motor protection circuit. AE1
		Motor protection circuit returns by the signal of operation of an opposite direction. Turn on the power again. AE2
Received the alarm signal. AE2		
Leakage from valve seat	Seat is worn or damaged.	Replace the valve.
Leakage from valve stem	Packing is worn or distorted.	

For more information contact
NIPPON VALVE CONTROLS, INC. for consultation.