



**Please read this document before using these valves.**

**GENERAL**

This series is suitable for main or bypass valve in piping system.

Manual operation

Handle

Valve

- AE type Long neck.
- E type For general use.
- EJ type For general use.
- EG type For high temp.
- TE type Long neck.
- EL type For general use.
- TV type For diversion flow and mixing.

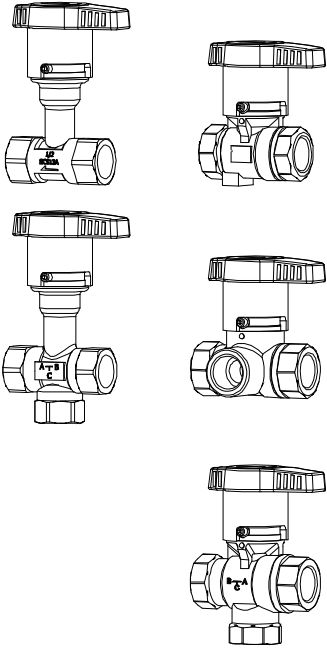





**PRODUCT CODE**

AE type	M A C A E T - 5 T T P - [ ] - [ ]		
E type (Brass)	M A C E - T - 5 Y Y F - [ ] - [ ]		
(Stainless)	M A C E - T - 5 U U T - [ ] - [ ]		
EJ type	M A C E J T - 5 U U T - [ ] - [ ]		
EG type	M A C E G T - 5 U U P - [ ] - [ ]		
TE type	M A C T E T - 5 T T P - [ ] - [ ]		
EL type	M A C E L T - 5 U U T - [ ] - [ ]		
TV type	M A C T V T - 5 T T P - [ ] - [ ]		
	(1) (2) (3) (4) (5) (6) (7) (8) (9) (10)		
(1) Actuator MAC	(5) Connection 5 : Threaded End Rc	(8) Seat material P : R-PTFE F : F-PTFE T : PTFE	(10) Option
(2) Valve AE E- EJ EG TE EL TV	(6) Body material T : SCS13A Y : C3771BE U : SCS14A	(9) Size [mm] ex. 25 A → 025	
(3) Operation T : Handle	(7) Ball material T : SCS13A / SUS304 Y : C3771BE / C3604BD U : SCS14A / SUS316		
(4) Hyphen			

**VALVES SPECIFICATIONS**

 Water 
  Oil 
  Air, Gas 
  Steam 
  Chemicals 
  Sea water 
  Slurry 
  Negative pressure

AE type

Valve type	AE	
Design	2 way, Reduced port	
Connection	Threaded End Rc	
Fluid	   	
Max pressure	1 MPa	
Size [mm]	015 to 025	
Material	Body	SCS13A
	Ball	SUS304
	Seat	R-PTFE
Stem seal	Packing	PTFE
	O-ring	FKM

**PRESSURE & TEMPERATURE RATING**

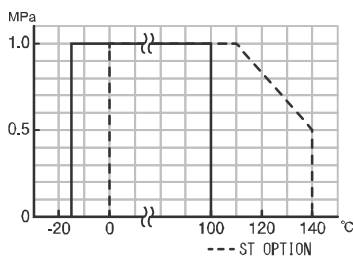

The optional for steam fluids.

Valve type	Option code	O-ring
AE	ST	Replace (Steam resistant FKM)



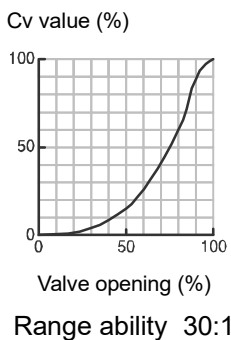

**INHERENT FLOW CHARACTERISTIC**



**VALVES SPECIFICATIONS**

 Water 
  Oil 
  Air, Gas 
  Steam 
  Chemicals 
  Sea water 
  Slurry 
  Negative pressure

E EJ EG type

Valve type	E (Brass)		E (Stainless)		EJ	EG	
Design	2 way, Standard port		2 way, Standard port		2-way, Full port	2 way, Standard port	
Connection	Threaded End Rc		Threaded End Rc		Threaded End Rc	Threaded End Rc	
Fluid							
Max pressure	1 MPa		2 MPa	1 MPa	1 MPa	1 MPa	
Size [mm]	015 to 025	032 to 050	008 to 010	015 020 to 050	015 to 040	015 to 050	
Material	Body	C3771BE (Plated)		SCS14A		SCS14A	SCS14A
	Ball	C3604BD (Plated)	C3771BE (Plated)	SUS316	SCS14A	SCS14A / SUS316	SCS14A
	Seat	F-PTFE		PTFE		PTFE	R-PTFE
Stem seal	O-ring	FKM		FKM		FKM	Steam resistant FKM

**PRESSURE & TEMPERATURE RATING**

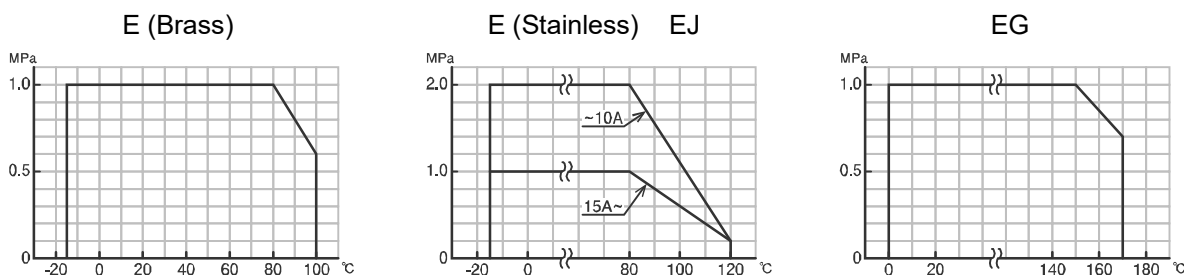

**INHERENT FLOW CHARACTERISTIC**

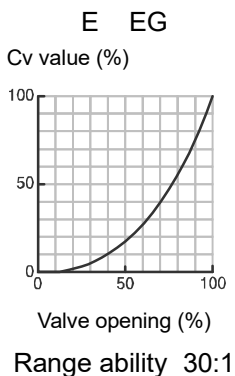

**VALVES SPECIFICATIONS**

Water 
 Oil 
 Air, Gas 
 Steam 
 Chemicals 
 Sea water 
 Slurry 
 Negative pressure

TE EL TV type

Valve type	TE		EL		TV	
Design	3 way, Reduced port		3 way, Standard port		3 way, Standard port	
Connection	Threaded End Rc		Threaded End Rc		Threaded End Rc	
Fluid						
Max pressure	1 MPa		1 MPa		1 MPa	
Size [mm]	015 to 025		008 to 015	020 to 050	015 to 025	032 to 040
Material	Body	SCS13A	SCS14A		SCS13A	
	Ball	SUS304	SUS316	SCS14A	SUS304	SCS13A
	Seat	R-PTFE	PTFE		R-PTFE	
Stem seal	Packing	PTFE	-		-	
	O-ring	FKM	FKM		FKM	

The optional for steam fluids.

Valve type	Option code	O-ring
TE	ST	Replace (Steam resistant FKM)

**PRESSURE & TEMPERATURE RATING**

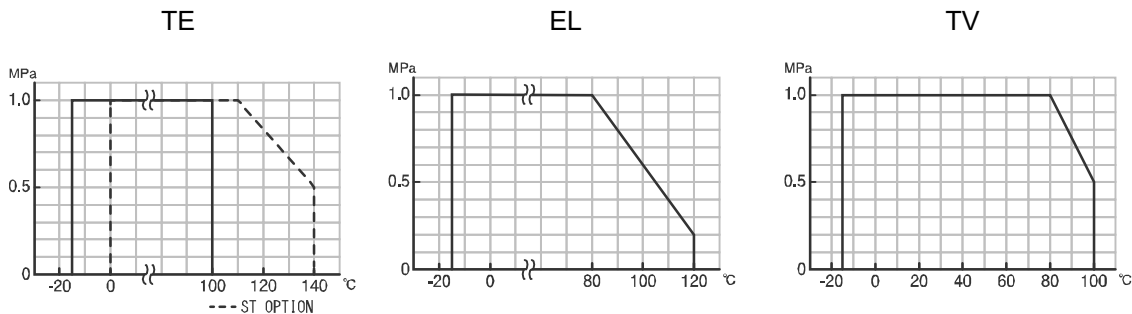

**INHERENT FLOW CHARACTERISTIC**

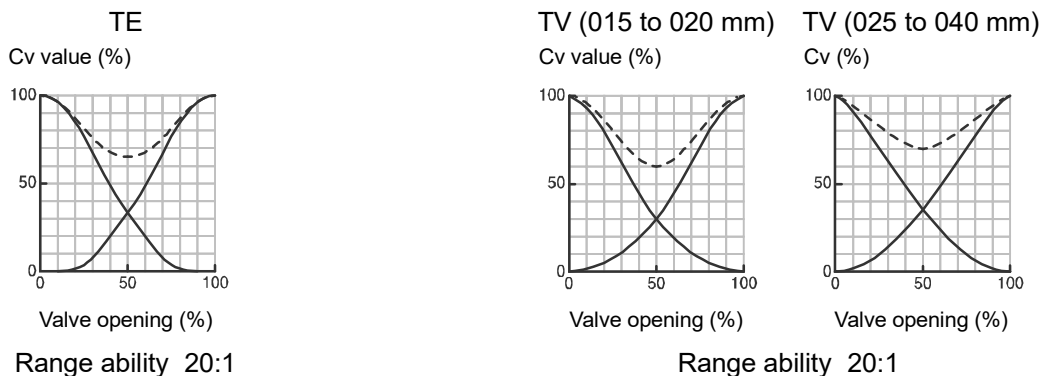

**FLOW PATHS (Position① / P1) (Position② / P2)**

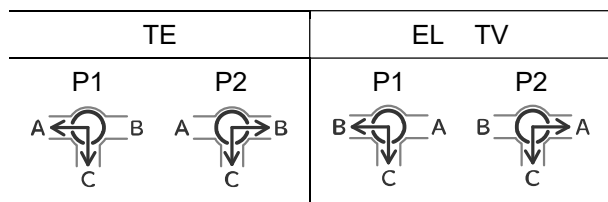

Note) When a closed path is exposed to high pressure, it may leak slightly to an open path.

**INSTALLATION, OPERATION & MAINTENANCE INSTRUCTIONS**

**HANDLING & STORAGE**

①HANDLING

Do not drop or throw the product as it may break.

②STORAGE

- Store away from dust, moisture and direct sunlight. If possible, store in the original package.
- Do not remove a dust proof cap until the piping.

③CHECKING

Check the product code before installation.

**INSTALLATION**

①PRECAUTIONS

- Flush the pipeline carefully before installing the valve. Foreign particles, such as sand or pieces of welding electrode, will damage the ball and seats.
- For valves with specified flow direction (AE, EG) or with ST / SC option, check the arrows on the product before piping.
- When the flow path is subjected to a high pressure from arrow, it may leak slightly to the low pressure port. (TE, EL, TV)

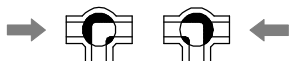

②PIPING

- Using a pipe with too long a thread will damage the valve.
  - If sealing tape or sealant gets inside the valve, the valve seat leaks or malfunctions.
  - To prevent the valve from being damaged by stress, always hang a wrench on the end of the valve on the side where the pipe is to be connected when screwing in the pipe or when unscrewing it after correcting the angle. (Fig a and b)
- Do not apply excessive force to the valve with a pipe wrench or the like.

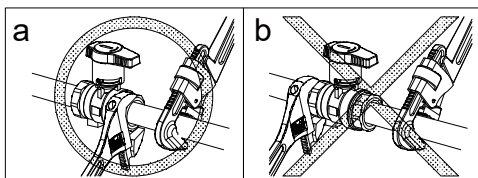

- Refer to the recommended tightening torque table and do not apply excessive torque.

Valve size [mm]	Torque [N·m]
008 to 010	15 to 20
015	25 to 35
020	40 to 50
025	50 to 60
032	60 to 80
040	75 to 85
050	90 to 110

③ENVIRONMENT

If there is a possibility that the fluid and drive part freeze, please take measures to prevent freezing.

④POSITIONING

Should be positioned through 90° upward from horizontal. Provide space around the product to allow manual operation, inspection and replacement work.

**MAINTENANCE**

Do the routine maintenance at least once in half a year.

Inspection items

- Confirm operation of opening and closing.
- Confirm the fluid temperature or pressure.
- Confirm the leak from valve stem.

**TROUBLESHOOTING**

Problem	Cause	Solution
Stop in the mid position.	<ul style="list-style-type: none"> <li>• Biting of valve seat.</li> <li>• The scale has adhered to the valve ball.</li> </ul>	Remove a foreign object.
Leakage from valve body	<ul style="list-style-type: none"> <li>• Valve cap get loose.</li> <li>• Valve body is damaged.</li> </ul>	Replace the valve.
Leakage from valve seat	Seat is worn or damaged.	
Leakage from valve stem	Stem packing is worn or distorted.	

For more information contact NIPPON VALVE CONTROLS, INC. for consultation.