

**Please read this manual before installation and use.**

**GENERAL**

The actuator operates at the time of power loss by the built-in high-performance shielded battery.

Built-in battery life is 8 to 9 years at 25 °C.

It's possible to use for a wide range of temperature (ambient temperature: -20 to +50 °C).

The battery composed by dry type structure the maintenance of saving water is not necessary.

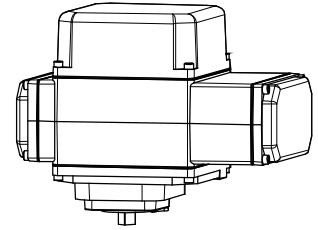

ABR : For AC / DC power

HBR : For AC / DC power (High speed)

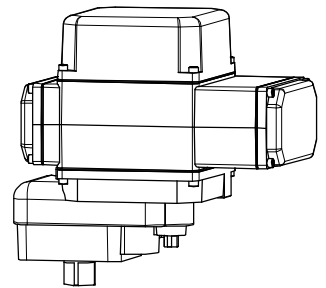
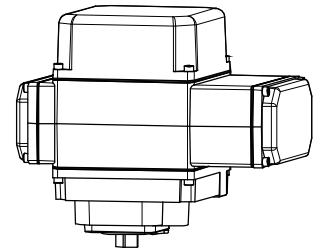

**PRODUCT CODE**

ABR type	A B R -	<input type="text"/>	-	<input type="text"/>	-	<input type="text"/>	-	<input type="text"/>
HBR type	H B R -	<input type="text"/>	-	<input type="text"/>	-	<input type="text"/>	-	<input type="text"/>
	(1)	(2)	(3)	(4)	(5)			

(1) Actuator	(2) Torque	(3) Voltage	(4) Operation mode	(5) Power failure
ABR	300	1 : 100 / 110 V AC	Nil : Mode A	Nil : Response mode
HBR	700	2 : 200 / 220 V AC	Q : Mode B	Z : Standby mode
	02K	0 : 24 V DC		S : Hold the valve position
	06K			

**ELECTRIC ACTUATOR SPECIFICATIONS**

3 way valve: SHUT / Position①, OPEN / Position②

Actuator type (□: Voltage code)	ABR-300-□	ABR-700-□	HBR-300-□	HBR-700-□	HBR-02K-□	HBR-06K-□
Voltage	100 / 110 V AC ±10 % 50/60 Hz (Code: 1) 200 / 220 V AC ±10 % 50/60 Hz (Code: 2) 24 V DC (Code: 0) <span style="float: right;">Note) Cannot use a half or full-wave DC power.</span>					
Rated torque [N·m]	30	70	30	70	200	600
Operation time [s]	3 to 4	6 to 10	1 to 2	3 to 5	AC: 8 to 15 DC: 12 to 17	AC: 24 to 45 DC: 36 to 50
Power consumption (Max) [VA]	AC power 100 DC power 80		AC power 150 DC power 120			
Motor	DC motor					
Overload protection	Current limiter					
Control switch	a-contact input type, with built-in relay					
Operation *1	[Mode A] SW is OFF → SHUT. SW is ON → OPEN. (Standard) [Mode B] SW is ON → SHUT. SW is OFF → OPEN. (Option: Q)					
Power failure *2	[Response mode] (Standard) Mode A: SHUT (End of operation) Mode B: OPEN (End of operation) [Standby mode] (Option: Z) After power failure, waiting for an external signal input to the switch in a fixed period. Waiting time of power failure: more than 50 hours (It becomes short due to the influence of use environment.) Shift the valve to OPEN / SHUT (or HOLD) by battery out. Stop waiting for the external input signal.					
Battery	Compact seal lead acid battery: 12 V, 2.5 Ah * It is recommend to exchange a battery for every 5 years (at 25 °C).					
Charge system	Constant voltage charge current					
Input signal current	2.5 mA 12 V DC (O-terminal) Leakage current in SW: less than 0.5 mA					
Output signal rating	Resistance load : 0.5 A 120 V AC / 0.6 A 24 V DC Micro load : 1 mA 5 V DC					
Alarm signal	Overtorque : It returns by power supply OFF or reverse operating signal. Battery out : The contacts turn on as battery consumption progresses.					
Duty cycle	20 % 15 min.					
Ambient temperature	-20 to 50 °C					
Space heater	Built in to the control board					
Manual operation	Manual over-ride with clutch. (Direct operation / 06K: Operation by manual shaft.)					
Enclosure	Equivalent to IP65 (IEC 60529)					
Housing material	AC4C Aluminum alloy castings (acrylic resin baking finish)					
Terminal block	For bare wire 0.2 to 2.5 mm <sup>2</sup> (AWG 24 to 12) , Ground terminal: M3					
Conduct port	2-G1/2 Attachments: Cable gland (for Φ6 to 12 mm cable), plug.					

\*1 Change by DIP switch. (Standard → Mode B)

\*2 Change by DIP switch. (Standard → Standby mode)

**OPERATION / POWER FAILURE**

Operation	Input signal		Power failure	Battery out	Factory settings	Option code
	OFF	ON				
Mode A (Standard)	SHUT	OPEN	SHUT (End of operation)	-	Response mode	Standard (Nil)
			Hold the current valve position (Waiting for an external signal)	SHUT	Standby mode	Option: Z
				HOLD		
Mode B (Option: Q)	OPEN	SHUT	OPEN (End of operation)	-	Response mode	Option: Q
			Hold the current valve position (Waiting for an external signal)	OPEN	Standby mode	Option: Q-Z
				HOLD		

**ELECTRIC ACTUATOR SPECIFICATIONS**

3 way valve: SHUT / Position①, OPEN / Position②

**WIRING**

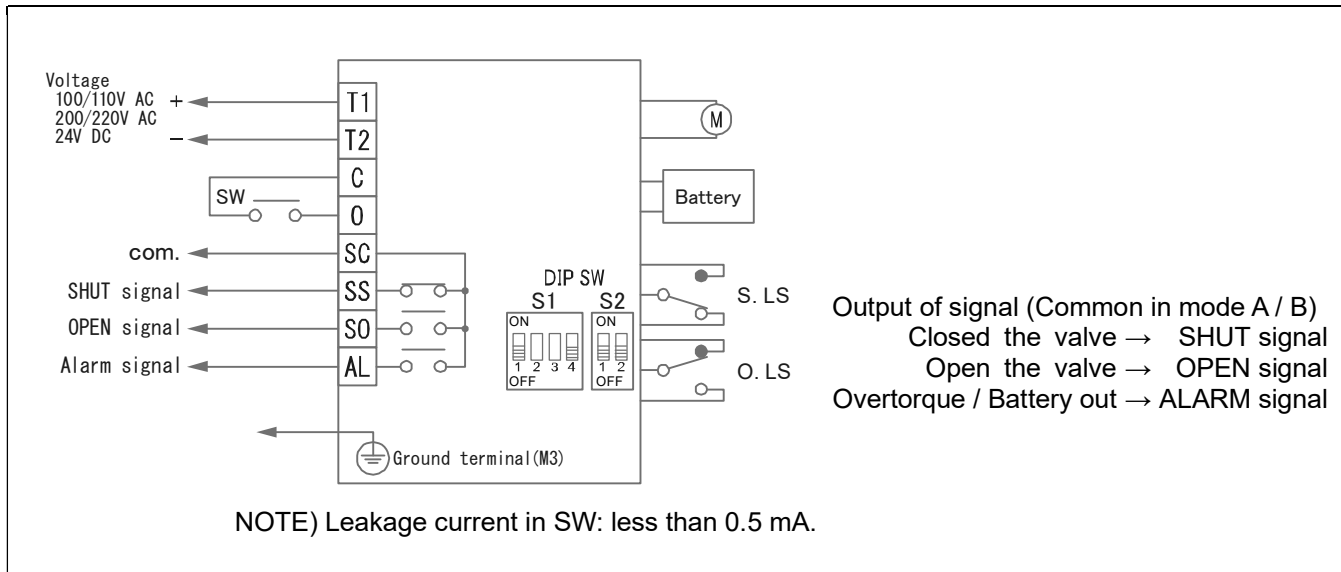

DIP switches S1-2 and S1-3 are for changing ABR / HBR (factory setting only), so do not change the settings.



**SETTING WITH DIP SW**

	DIP SW			Operation				Option code	
	S2-1	S1-1	S1-4	Input signal		Power failure	Battery out		
	Power failure	Mode A / B	Battery out	OFF	ON				
Response mode (Standard)	ON OFF 1 2	ON OFF 1 2 3 4	ON OFF 1 2 3 4	SHUT	OPEN	SHUT	/	Standard (Nil)	
		ON OFF 1 2 3 4		OPEN	SHUT	OPEN		Option: Q	
Standby mode (Option: Z)	ON OFF 1 2	ON OFF 1 2 3 4	ON OFF 1 2 3 4	SHUT	OPEN	HOLD	SHUT	Option: Z	
			ON OFF 1 2 3 4				HOLD	Option: Z-S	
		ON OFF 1 2 3 4	ON OFF 1 2 3 4	ON OFF 1 2 3 4	OPEN	SHUT		OPEN	Option: Q-Z
			ON OFF 1 2 3 4	ON OFF 1 2 3 4				HOLD	Option: Q-Z-S

**OPTIONAL PARTS**

Specifications		Code No.	Remarks
Operation mode	SW is OFF → SHUT , SW is ON → OPEN.	Nil	Mode A (Standard)
	SW is ON → SHUT , SW is OFF → OPEN.	Q	Mode B
Manual lever handle	Mounted on the drive shaft.	M0	Except HBR-06K.

**ELECTRIC ACTUATOR SPECIFICATIONS**

**DIMENSIONS**

**ABR / HBR**

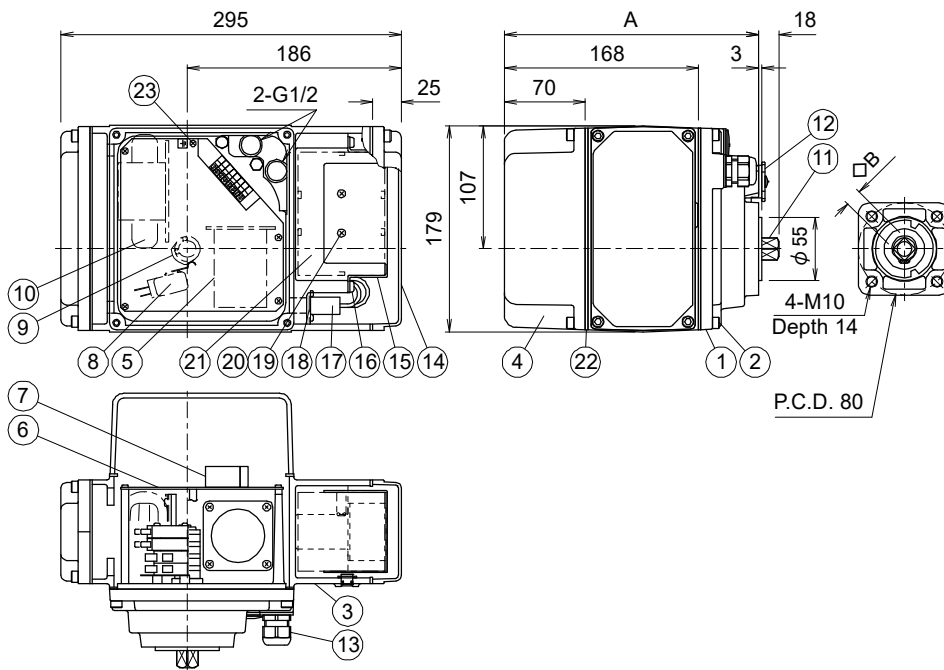

		Actuator	
A	B	ABR	HBR
220	14	300	300
		700	700
242	19	-	02K

**HBR (06K)**

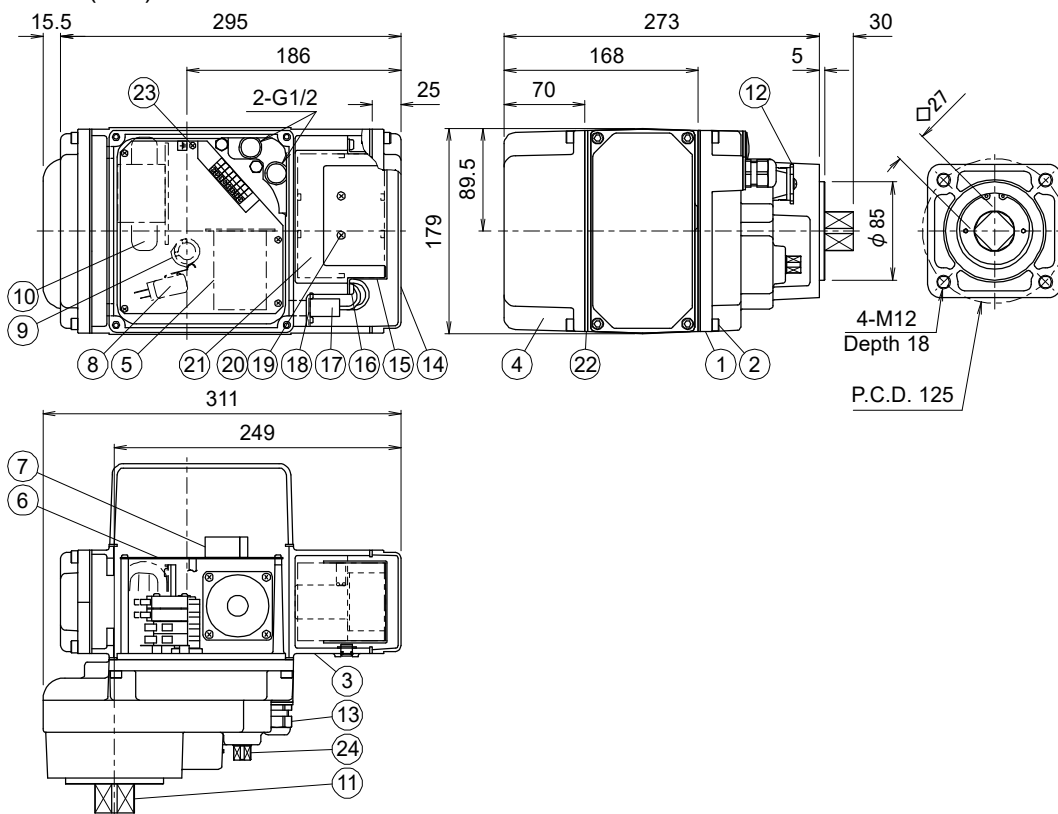

**Parts name**

1	Body	7	Terminal block	13	Cable gland	19	Battery fix screw
2	Body cover lower part screw	8	Limit switch	14	Battery cover	20	Nut
3	Body cover	9	SW setting cam	15	Battery bracket	21	Battery
4	Motor cover	10	Transformer	16	Bracket fix screw	22	Rubber packing
5	Motor	11	Drive shaft	17	Battery connector	23	Earth screw (M3)
6	Control board	12	Manual clutch	18	Relay board	24	Manual shaft (For 06K)

**INSTALLATION, OPERATION & MAINTENANCE INSTRUCTIONS****HANDLING & STORAGE****①HANDLING**

Proper care in handling the actuator should be taken to prevent damage. Do not drop or throw it.

**②STORAGE**

- Store the actuator in the protected area from dust, moisture, and direct sunlight. If possible, should be kept in the original packaging.
- If it is not used more than 30 days, remove a battery from actuator and keep it in a place with little humidity.

**③CHECKING**

- Check the product code, power supply, and voltage before installation.
- Make sure that the bolts are not loose.
- DIP switch be sure perform set up before a power supply injection.

Should not change an unnecessary switch.

**④BATTERY CONNECTOR (Power failure: OPEN)**

- For the following models, Battery connector is not connected before shipment.

Please connect before use.

ABR (Option: Q)

HBR (Option: Q)

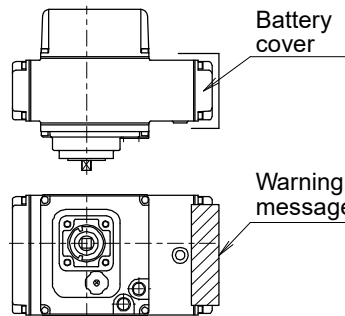

- It may move unexpectedly by connecting the battery connector. Please be careful...

**INSTALLATION****①ENVIRONMENT**

- Do not install in place where corrosive gas is present or where vibration is heavy (0.5 G or more).
- When radiant heat causes the surface temperature of the control unit to exceed 50°C, provide an appropriate shielding plate.
- If there is a possibility that the fluid and drive part freeze, please take measures to prevent freezing.

**②POSITIONING**

- Should be positioned through 90° upward from horizontal. Provide space around the product to allow manual operation, inspection and replacement work.
- Be sure to enough space around the actuator for battery replacement.

Maintenance space for upper part of actuator.

ABR	HBR	More than 70 mm
-----	-----	-----------------

**③OTHER NOTES**

Until the wiring is completed there must be no condensation or flooding in the interior of the actuator, after piping. Protective caps on the cable gland are not waterproof.

**INSTALLATION, OPERATION & MAINTENANCE INSTRUCTIONS****WIRING****① PRECAUTIONS**

- Remove the actuator cover before wiring.
- Two G1/2 electrical connections are provided with a cable gland and plug. Usable cable size is  $\Phi 6$  to 12 mm.
- When using a flexible tube, dew condensation may occur inside the actuator due to respiration from the inside of the tube and malfunction may result. Seal the flexible tube connector part with a sealant.
- Sealants that affect the electrical contacts should not be used inside the electric actuator.
- If long distance wiring or low voltage operation, check that terminal voltage is in the proper range.
- Do not remove the body cover lower screw.

**② CONNECTION**

- Do not wiring outdoors on a rainy day.
- Check the power supply and voltage. Connect the signal as shown in the wiring diagram. Do not connect unnecessarily terminal.
- Actuator should be electrically grounded. Use the terminal marked ( $\perp$ ) inside the actuator.

**PREVENT DEW CONDENSATION**

- When installing the cover after wiring, perform the bolt by the temporary tightening procedure and the permanent tightening procedure to tightly and securely tighten the rubber packing so that water does not enter from the outside.
- Tighten the cable gland nut so that there is no leakage from the wire entrance.

**CONTROL****① CONTROL OF SWITCHING**

When using control switch with current leakage (more than 0.1 mA) such as TRIAC or relay with CR, it can cause malfunction.

**② DC POWER SUPPLY**

- Cannot use a half or full-wave power supply.
- Consider an inrush current of motor. (It is 1.5 to 3 times of consumed current.)
- When using a DC voltage, be selected the wire thickness by the wiring distance.
- Do not use power supply that require more than 1 second with rise and fall time.

**③ USE OF OPEN/SHUT SIGNALS**

Use signals within the capacity of output signal rating.

**④ OPERATION MODE**

The input signal and operation mode are set as follows. (Factory shipped)

Operation mode	Mode A
Operation	SW is OFF → SHUT SW is ON → OPEN
Power failure	SHUT

**OPERATION****① ABR-Q and HBR-Q (Power failure: OPEN)**

Battery connector is not connected before shipment. Please connect before use.

**② TESTING**

- Before operation, charge of 24 hours or more is performed.
- Make sure that power supply voltage is correct. Also check operating position, wiring, speed and signals.
- During trial operation, check that valve movement and OPEN and SHUT signals are correct.

**③ DUTY CYCLE**

Confirm that the operation frequency is within the specified duty cycle.

Use beyond the load time rate range will affect product life. Also, it may cause burnout.

Duty cycle is a value that regulates the opening / closing frequency of the actuator. The meaning of 20 % 15 minutes for Duty cycle is that 3 minutes (20 % of 15 minutes) operation is possible. The calculated value obtained by dividing 3 minutes by the operation time is the number of times of operation within 15 minutes.

**④ ATTENTION**

- Be sure to set the DIP-SW before turning on the power supply.
- Keep power supplied for built-in space heater to prevent condensation inside actuator.
- Do not touch the moving parts of actuator in operation.
- Do not insert a reverse signal during operation. It may shorten the life of product.
- Never put anything on the actuator or make it into a foothold.

## INSTALLATION, OPERATION & MAINTENANCE INSTRUCTIONS

### BATTERY

#### ① HANDLING

- The battery can be expected a service life over 8 to 9 years at 25 °C.
- Built-in battery should be keep reliability of operation, we recommend you to exchange every 5 years.

#### ② AFTERCARE

- Battery exchange can use during the power supplying.
- Please follow the attachment exchange manual or procedure with battery.
- Dispose of used batteries in the correct way. Order industrial waste disposers, or send them back to us.

### BATTERY REPLACEMENT

#### ① Remove the battery cover.

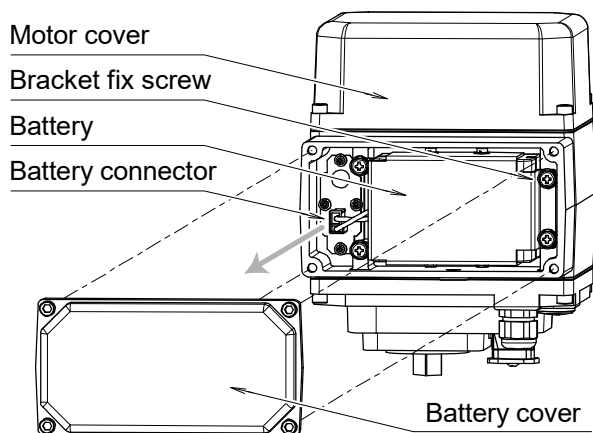

#### ② Remove the battery connector.

Hold the connector body and pull it straight forward. Do not pull electric wire by any means.

#### ③ Remove the bracket fix screw and battery.

#### ④ New battery is attached with a bracket fix screw.

#### ⑤ Insert the battery connector.

Please be sure to plug it straight in all the way.

#### ⑥ Attach the battery cover.

#### ⑦ Make sure that operation by battery is securely performed.

### MANUAL OPERATION

#### ① PRECAUTIONS

- Remove the battery connector before manual operation for safety. (Refer the battery replacement)
- Manual operation should be a temporary operation.
- Be sure to turn off the power before manual operation.
- Operate manually with reference to the opening degree label. Do not turn beyond the fully open / fully closed position. Operation failure may occur during automatic operation.

#### ② THE WAY OF OPERATION

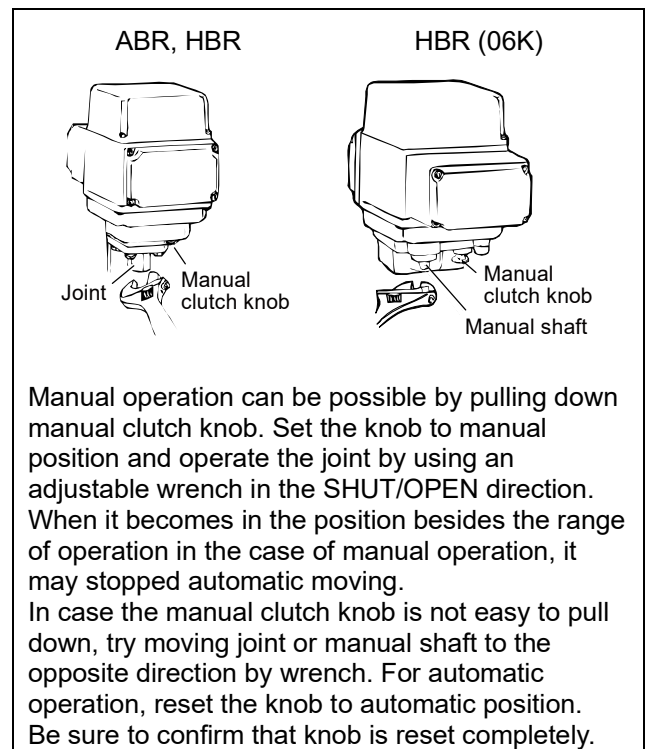

Before automatic operation, be sure to remove wrench.

### MAINTENANCE

- To prevent electric shock, be sure to turn off the power when removing the actuator cover.
- Do the routine maintenance at least once in half a year.

#### Inspection items

- Confirm operation of opening and closing.
- Confirm that an actuator is not hot excessively.
- Confirm existence of abnormal noise and vibration during operation.
- Confirm whether screws are loose or not.
- Confirm that water or condensation no remains in the actuator.
- Turn off the power and check if the valve operates normally with built-in battery.

**INSTALLATION, OPERATION & MAINTENANCE INSTRUCTIONS****TROUBLE SHOOTING**

Problem	Cause	Solution
Actuator does not move.	Faulty wiring.	Correct the wiring.
	No voltage is coming.	Check the voltage.
	Incorrect voltage.	When it's burned out by excess voltage, replace the actuator.
	Short the circuit, contact failure.	Review wires and connection.
	Motor is too old.	Replace the actuator. Repair in our factory.
	Battery lifetime.	Replace the battery.
Operation is unstable.	Excess surge or voltage was applied.	<ul style="list-style-type: none"> <li>• Replace the control board or limit switch. (Repair in our factory)</li> <li>• Replace the actuator.</li> </ul>
	Rainwater entered the actuator.	<ul style="list-style-type: none"> <li>• Dry the inside.</li> <li>• Replace the actuator.</li> </ul>
	Added high harmonics noise from an inverter.	Attachment a filter for each inverter maker option.
	Effect of high level noise.	Use the shielded wire and ground the wiring. Separate signal wire from power line.
	Switch leakage current is large.	Current leakage should be less than 0.5 mA.

Problem	Cause	Solution
Stop in the mid position.	Biting of valve seat.	Manually operate an actuator and remove a foreign object.
	Overload protector runs because of over-torque.	Motor protection circuit returns by the signal of operation of an opposite direction. Turn on the power again.
	Battery is worn out.	Replace the battery.
Received the alarm signal.		
Stop automatic moving after manual operation.	Manual clutch knob is not reset.	Reset manual clutch knob.
	Out of operating range. (06K)	Reset by manual operation.

For more information contact  
NIPPON VALVE CONTROLS, INC. for consultation.