



Instruction manual

Please read this manual before installation and use.

GENERAL

It composed of wafer type butterfly valve and high-power electric actuator.

Actuator

- AD1 : For AC power
- AD2 : For AC / DC power
- AD0 : For DC power
- HD1 : For AC power (High speed)
- HD2 : For AC / DC power (High speed)
- HD0 : For DC power (High speed)
- AE1 : For AC power
- AE2 : For AC power

Valve

- F type FCD450 body.
- FN type FCD450 body.
- FE type Aluminum alloy diecast body. (lightweight)
- FZ type Long neck.
- FP type For Corrosion resistance. (Polypropylene body)

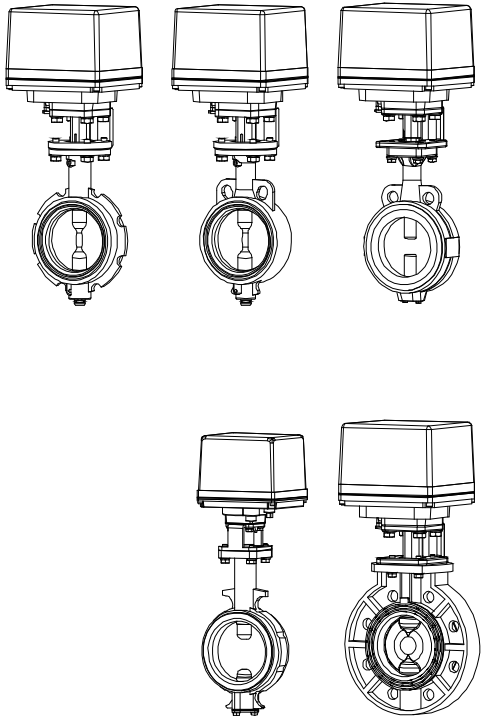

PRODUCT CODE

F type	<input type="checkbox"/> <input type="checkbox"/> <input type="checkbox"/>	F -	<input type="checkbox"/> <input type="checkbox"/>	1	D	<input type="checkbox"/> <input type="checkbox"/>	-	<input type="checkbox"/> <input type="checkbox"/> <input type="checkbox"/>	-	<input type="checkbox"/> <input type="checkbox"/>	
FN type (For JIS 5K / 10K)	<input type="checkbox"/> <input type="checkbox"/> <input type="checkbox"/>	FN	<input type="checkbox"/> <input type="checkbox"/>	1	D	<input type="checkbox"/> <input type="checkbox"/>	-	<input type="checkbox"/> <input type="checkbox"/> <input type="checkbox"/>	-	<input type="checkbox"/> <input type="checkbox"/>	
FE type	<input type="checkbox"/> <input type="checkbox"/> <input type="checkbox"/>	FE	<input type="checkbox"/> <input type="checkbox"/>	1	L	T	<input type="checkbox"/>	-	<input type="checkbox"/> <input type="checkbox"/> <input type="checkbox"/>	-	<input type="checkbox"/> <input type="checkbox"/>
FZ type (For JIS 5K / 10K)	<input type="checkbox"/> <input type="checkbox"/> <input type="checkbox"/>	FZ	<input type="checkbox"/> <input type="checkbox"/>	1	L	<input type="checkbox"/> <input type="checkbox"/>	-	<input type="checkbox"/> <input type="checkbox"/> <input type="checkbox"/>	-	<input type="checkbox"/> <input type="checkbox"/>	
FP type	<input type="checkbox"/> <input type="checkbox"/> <input type="checkbox"/>	FP	<input type="checkbox"/> <input type="checkbox"/>	1	Q	Q	E	-	<input type="checkbox"/> <input type="checkbox"/> <input type="checkbox"/>	-	<input type="checkbox"/> <input type="checkbox"/>
	(1)	(2)	(3)	(4)	(5)	(6)	(7)	(8)	(9)	(10)	

(1) Actuator AD1 AD2 AD0 HD1 HD2 HD0 AE1 AE2	(4) Sizing code 0 : Standard 1 : Light 2 : Heavy	(7) Disc material D : FCD450 U : SUSF316 / SCS14 A : CAC703 T : SCS13A J : PPS Q : PP	(10) Option L0 : Auxiliary limit switch L2 : Auxiliary limit switch M0 : Manual lever handle
(2) Valve F- FN FE FP FZ	(5) Connection 1 : JIS 10K	(8) Seat material E : EPDM B : NBR V : FKM	
(3) Voltage 1 : 100 / 110 V AC 2 : 200 / 220 V AC 0 : 24 V DC	(6) Body material D : FCD450 L : ADC12 Q : PP	(9) Size [mm] ex. 80 A → 080	

VALVES SPECIFICATIONS

Water
 Oil
 Air, Gas
 Steam
 Chemicals
 Sea water
 Slurry
 Negative pressure

F FN FE FP type

Valve type	F		FN		FE		FP		
Design	Wafer type		Wafer type		Wafer type		Wafer type		
Connection	JIS Flanges 10K		JIS Flanges 5K / 10K		JIS Flanges 10K		JIS Flanges 10K		
Fluid									
Max pressure	1 MPa	0.5 MPa	1 MPa	0.98 MPa	1 MPa	0.7 MPa			
Size [mm]	050 to 250	300	050 to 200	040 to 300	040 to 150	200 to 300			
Material	Body	FCD450		FCD450		ADC12		PP	
	Disc	FCD450 (CNI plated) CAC703 SUSF316 / SCS14		FCD450 (CNI plated) CAC703 SUSF316 / SCS14		SCS13A		PP	
	Seat	EPDM NBR	FKM	EPDM NBR		EPDM NBR		EPDM	
Stem seal	O-ring	NBR	FKM	NBR		NBR		EPDM	

PRESSURE & TEMPERATURE RATING

F FN

Seat material	Fluid temp.	Use
EPDM	-20 to +80 °C	
NBR	-10 to +60 °C	
FKM	-5 to +80 °C	

FE

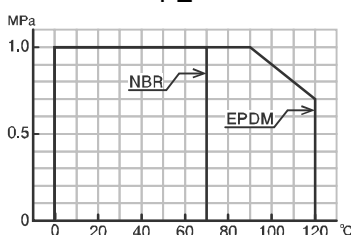

FP

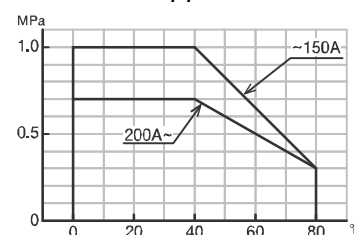

- NOTE) • EPDM is not recommended for hydrocarbon-based oil or grease.
 • Hot water can be used at temperatures of up to 80 °C (FE: 90 °C). Steam cannot be used.
 • CAC703 and EPDM are suitable for seawater. (F, FN)

INHERENT FLOW CHARACTERISTIC

F FN

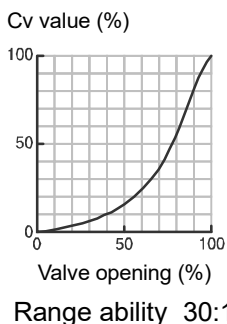

FE

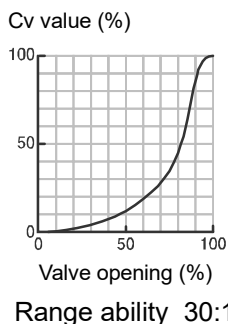

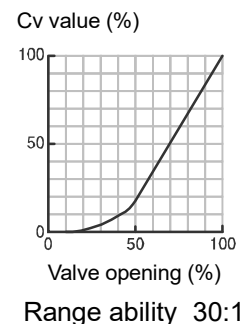

FP



VALVES SPECIFICATIONS

 Water
  Oil
  Air, Gas
  Steam
  Chemicals
  Sea water
  Slurry
  Negative pressure

FZ type

Valve type	FZ		
Design	Wafer type		
Connection	JIS Flanges 5K / 10K		
Fluid	  		
Max pressure	1 MPa		
Size [mm]	040 to 300	040 to 200	
Material	Body	ADC12	
	Disc	SCS14	PPS
	Seat	EPDM NBR	
Stem seal	O-ring	NBR	

PRESSURE & TEMPERATURE RATING

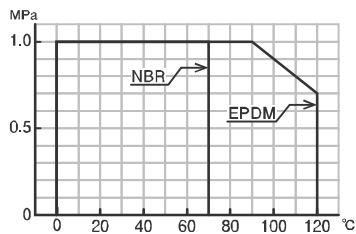

- NOTE) • EPDM is not recommended for hydrocarbon-based oil or grease.
 • Unsuitable for steam or hot water over 90 °C. (Steam cannot be used.)

INHERENT FLOW CHARACTERISTIC

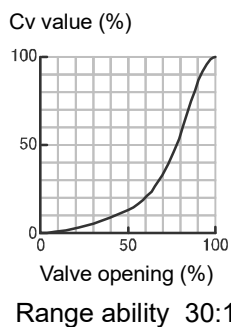

ELECTRIC ACTUATOR SPECIFICATIONS

AD1 HD1 type

Actuator type (□:Voltage code)	AD1-300-□	AD1-700-□	HD1-300-□	HD1-700-□	HD1-02K-□	HD1-06K-□
Voltage	100 / 110 V AC ±10 % 50/60 Hz (Code: 1) 200 / 220 V AC ±10 % 50/60 Hz (Code: 2)					
Rated torque [N·m]	30	70	30	70	200	600
Operation time [s]	3 to 4	6 to 10	1 to 2	3 to 5	8 to 15	24 to 45
Power consumption (Max) [VA]	100		150			
Motor	DC motor					
Overload protection	Thermistor					
Method of operation	Transfer input type					
Operation	Power to S → SHUT (SHUT PL is lit.) Power to O → OPEN (OPEN PL is lit.)					
Output signal rating	Resistance load 10 A 250 V AC (Minimum 27 mA)					
Duty cycle	20 % 15 min. (When ambient temperature is over 50 °C, 10 % 15 min.)					
Ambient temperature	-20 to 55 °C					
Space heater	0.8 W					
Manual operation	Manual over-ride with clutch. (Direct operation / 06K: Operation by manual shaft.)					
Enclosure	Equivalent to IP65 (IEC 60529)					
Housing material	Aluminum alloy diecast (acrylic resin baking finish)					
Wire connection	Terminal Block: M3, Ground terminal: M3					
Conduct port	2-G1/2 Attachments: Cable gland (for Φ6 to 12 mm cable), plug.					

WIRING

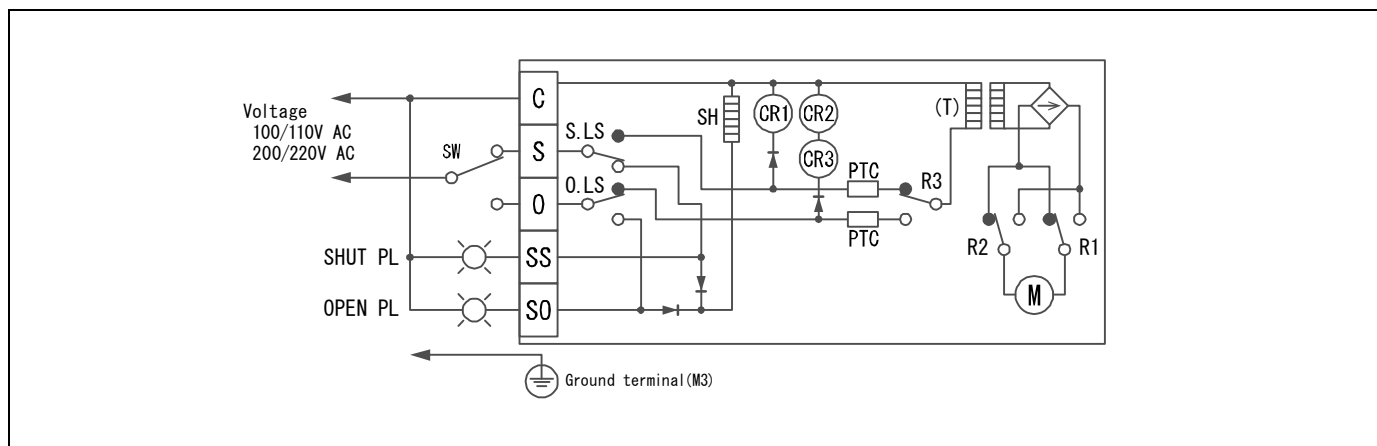

ELECTRIC ACTUATOR SPECIFICATIONS

AD2 HD2 type

Actuator type (□:Voltage code)	AD2-300-□	AD2-700-□	HD2-300-□	HD2-700-□	HD2-02K-□	HD2-06K-□
Voltage	100 / 110 V AC ±10 % 50/60 Hz (Code: 1) 200 / 220 V AC ±10 % 50/60 Hz (Code: 2) 24 V DC (Code: 0)					
Rated torque [N·m]	30	70	30	70	200	600
Operation time [s]	3 to 4	6 to 10	1 to 2	3 to 5	AC: 8 to 15 DC: 12 to 17	AC: 24 to 45 DC: 36 to 50
Power consumption (Max) [VA]	AC: 100 DC: 80		AC: 150 DC: 120			
Motor	DC motor					
Overload protection	Current limiter					
Method of operation	a-contact input type, with built-in relay					
Operation	SW is OFF → SHUT (R3 SW is ON) SW is ON → OPEN (R4 SW is ON) Over torque → R5 SW is ON					
Input signal current	10 mA 100 V AC / 6.5 mA 200 V AC / 38 mA 24 V DC (Leakage current in SW: less than 1 mA) *O terminal input: Photo coupler					
Output signal rating	Resistance load 0.5 A 125 V AC 1 A 24 V DC Micro load 1 mA 5 V DC					
Alarm signal	Output when the motor protection circuit operates by the overload. (it returns by power supply OFF or reverse operating signal)					
Duty cycle	20 % 15 min. (When ambient temperature is over 50 °C, 10 % 15 min.)					
Ambient temperature	-20 to 55 °C					
Space heater	0.8 W					
Manual operation	Manual over-ride with clutch. (Direct operation / 06K: Operation by manual shaft.)					
Enclosure	Equivalent to IP65 (IEC 60529)					
Housing material	Aluminum alloy diecast (acrylic resin baking finish)					
Wire connection	Terminal Block: M3, Ground terminal: M3					
Conduct port	2-G1/2 Attachments: Cable gland (for Φ6 to 12 mm cable), plug.					

WIRING

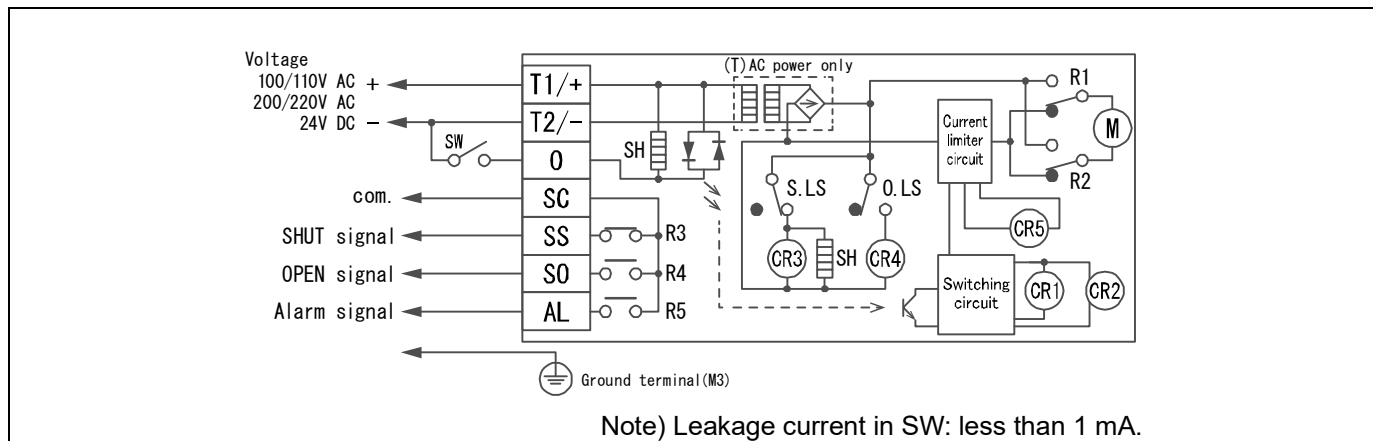

ELECTRIC ACTUATOR SPECIFICATIONS

AD0 HD0 type

Actuator type	AD0-300-0	AD0-700-0	HD0-300-0	HD0-700-0	HD0-02K-0	HD0-06K-0
Voltage	24 V DC					
Rated torque [N·m]	30	70	30	70	200	600
Operation time [s]	3 to 4	6 to 10	1 to 2	3 to 5	12 to 17	36 to 50
Power consumption (Max) [VA]	80		120			
Motor	DC motor					
Overload protection	Current limiter					
Method of operation	Switching polarity type					
Operation	2 + 3 - → SHUT (SHUT PL is lit.) 3 + 2 - → OPEN (OPEN PL is lit.) Over torque → Alarm PL is lit.					
Output signal rating	Resistance load 1 A to 35 mA 24 V DC					
Duty cycle	20 % 15 min. (When ambient temperature is over 50 °C, 10 % 15 min.)					
Ambient temperature	-20 to 55 °C					
Space heater	3 W		Space heater			
Manual operation	Manual over-ride with clutch. (Direct operation / 06K: Operation by manual shaft.)					
Enclosure	Equivalent to IP65 (IEC 60529)					
Housing material	Aluminum alloy diecast (acrylic resin baking finish)					
Wire connection	Terminal Block: M3, Ground terminal: M3					
Conduct port	2-G1/2 Attachments: Cable gland (for Φ6 to 12 mm cable), plug.					

WIRING

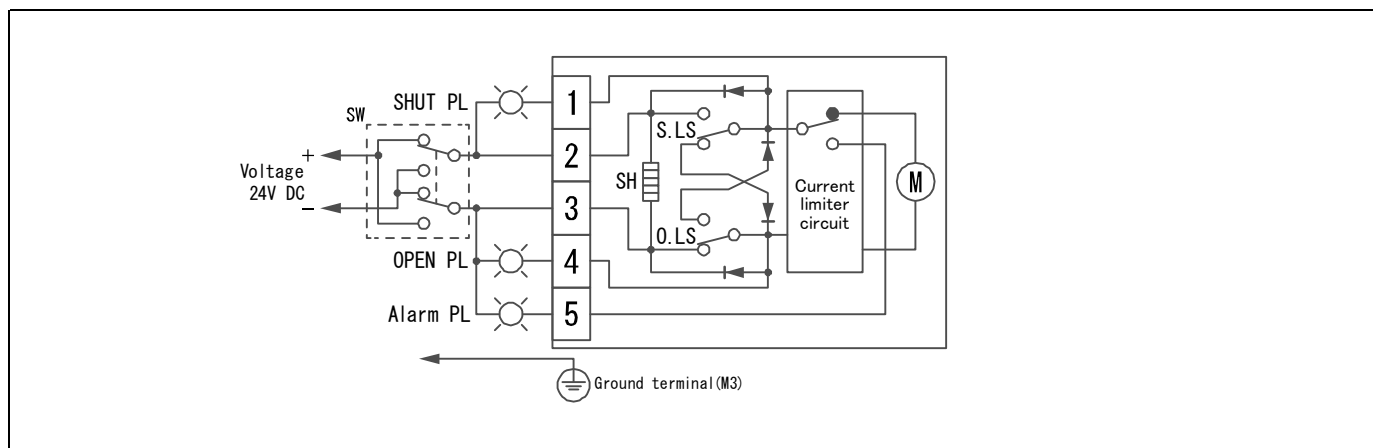

ELECTRIC ACTUATOR SPECIFICATIONS

AE1 type

Actuator type (□:Voltage code)	AE1-120-□	AE1-300-□	AE1-600-□	AE1-02K-□	AE1-06K-□
Voltage	100 / 110 V AC $\pm 10\%$ 50/60 Hz (Code: 1) 200 / 220 V AC $\pm 10\%$ 50/60 Hz (Code: 2)				
Rated torque [N·m]	12	30	60	200	600
Operation time [s]	10 / 8.5 (50/60 Hz)	7.2 / 6 (50/60 Hz)	15 / 12 (50/60 Hz)	30 / 25 (50/60 Hz)	
Power consumption [VA]	19	60		110	350
Motor	Synchronous motor	Reversible motor self-contained mechanical brake			
Overload protection	Thermal protector				
Method of operation	Transfer input type				
Operation	Power to S \rightarrow SHUT (SHUT PL is lit.) Power to O \rightarrow OPEN (OPEN PL is lit.)				
Output signal rating	Resistance load 3 A 250 V AC (Minimum 0.1 A)				
Duty cycle	20 % 15 min.				
Ambient temperature	-20 to 55 °C				
Space heater	3 W				
Manual operation	Manual shaft				
Enclosure	Equivalent to IP65 (IEC 60529)				
Housing material	Aluminum alloy diecast (acrylic resin baking finish)				
Wire connection	Terminal Block: M3, Ground terminal: M3				
Conduct port	2-G1/2 Attachments: Cable gland (for $\Phi 6$ to 12 mm cable), plug.				

WIRING

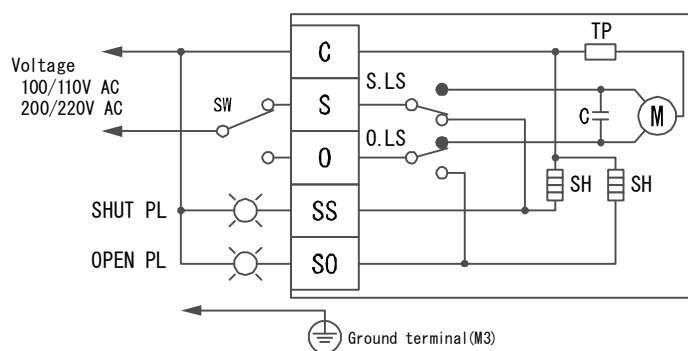

Note) Control switch should be prepared one by one for actuator.
Do not operate two or more actuator from one switch. It might malfunction.

ELECTRIC ACTUATOR SPECIFICATIONS

AE2 type

Actuator type (□:Voltage code)	AE2-120-□	AE2-300-□	AE2-600-□	AE2-02K-□	AE2-06K-□
Voltage	100 / 110 V AC $\pm 10\%$ 50/60 Hz (Code: 1) 200 / 220 V AC $\pm 10\%$ 50/60 Hz (Code: 2)				
Rated torque [N·m]	12	30	60	200	600
Operation time [s]	11 / 9.5 (50/60 Hz)	8.2 / 7 (50/60 Hz)	16 / 13 (50/60 Hz)	31 / 26 (50/60 Hz)	
Power consumption [VA]	26	60		110	350
Motor	Synchronous motor	Reversible motor self-contained mechanical brake			
Overload protection	Timer				
Method of operation	a-contactinput type, with built-in relay				
Operation	SW is OFF → SHUT (SHUT signal is output.) SW is ON → OPEN (OPEN signal is output.) Overtorque → Alarm signal is output				
Input signal current	9 mA (O-terminal) Leakage current in SW: less than 1 mA				
Output signal rating	Resistance load 0.5 A 125 V AC 1 A 24 V DC Micro load 1 mA 5 V DC				
Alarm signal	Output when the motor protection circuit operates by the overload. (it returns by power supply OFF or reverse operating signal)				
Duty cycle	20 % 15 min.				
Ambient temperature	-20 to 55 °C				
Space heater	3 W				
Manual operation	Manual shaft				
Enclosure	Equivalent to IP65 (IEC 60529)				
Housing material	Aluminum alloy diecast (acrylic resin baking finish)				
Wire connection	Terminal Block: M3, Ground terminal: M3				
Conduct port	2-G1/2 Attachments: Cable gland (for $\Phi 6$ to 12 mm cable), plug.				

WIRING

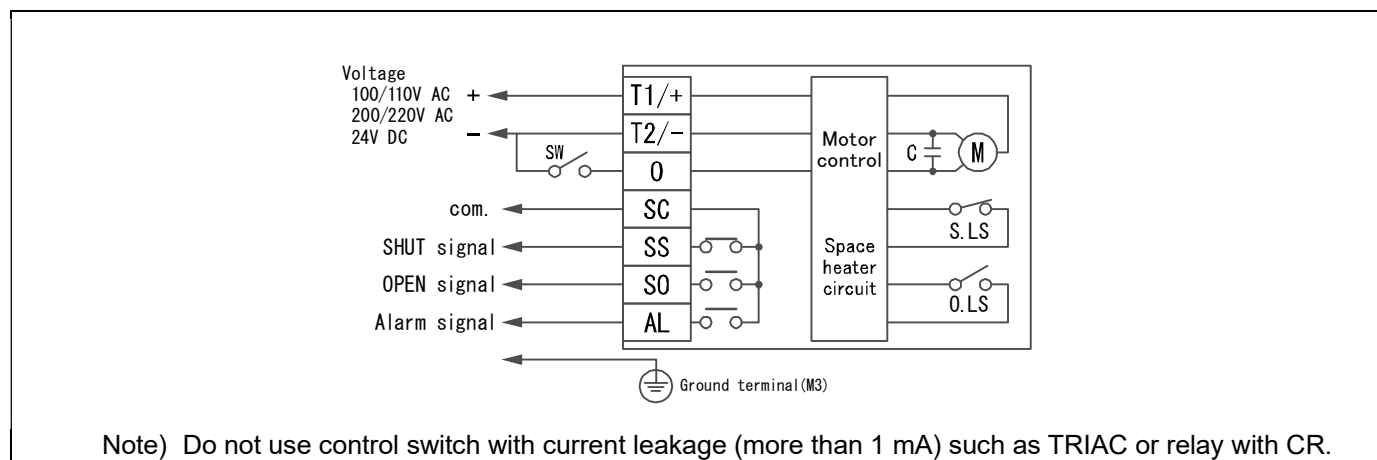

ELECTRIC ACTUATOR SPECIFICATIONS

OPTIONAL PARTS

Specifications		Code No.	AD	HD	AE	Remarks
Auxiliary limit switch	Select limit switch depending on the load	L0	○	○	○	For standard signal
		L2	○	○	○	For micro load signal
OPEN/CLOSE speed control board		I0	○			Set the operating time between 1.5 and 30 times.
Manual lever handle		M0	○	○		Mounted on the drive shaft. (except 06K)

*Auxiliary limit switch: Please refer to the specifications.

WIRING (OPTION)

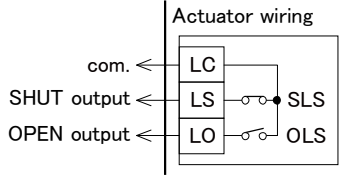
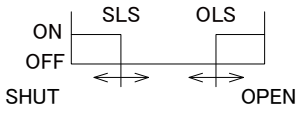
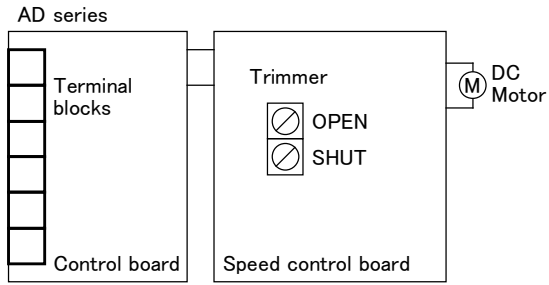
L0, L2	Auxiliary limit switch	I0	Speed control board (only for AD series)
 <p>At CLOSE side, LC and LS is ON. At OPEN side, LC and LO is ON.</p>  <p>ON point can be reset by adjusting the cam.</p>		 <p>Operating speed (OPEN/CLOSE) can be adjusted by "OPEN"/"SHUT" trimmer. Turning clockwise increases the operating time.</p>	

ELECTRIC ACTUATOR SPECIFICATIONS

DIMENSIONS

AD, HD

AD-300, 700 HD-300, 700

HD-02K

HD-06K

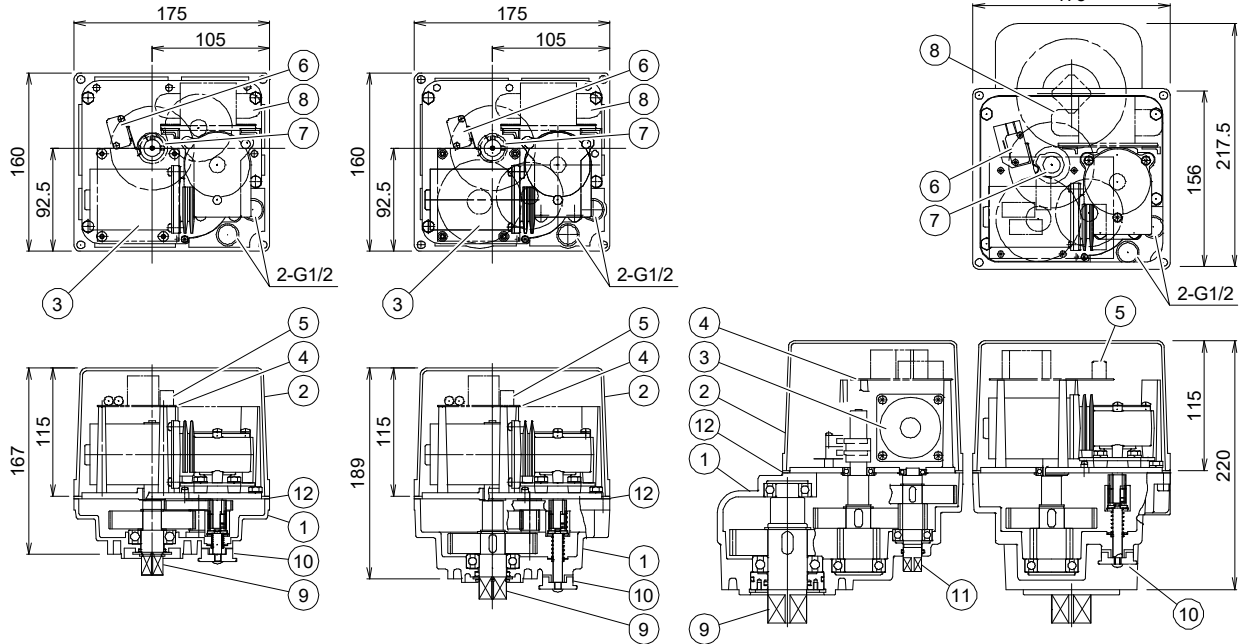

Parts name

1	Body	6	Limit switch	11	Manual shaft (For 06K)
2	Motor cover	7	SW setting cam	12	Rubber packing
3	Motor	8	Transformer		
4	Control board	9	Drive shaft		
5	Terminal block	10	Manual clutch		

AE

AE-120, 300, 360

AE-600, 700

AE-02K

AE-06K

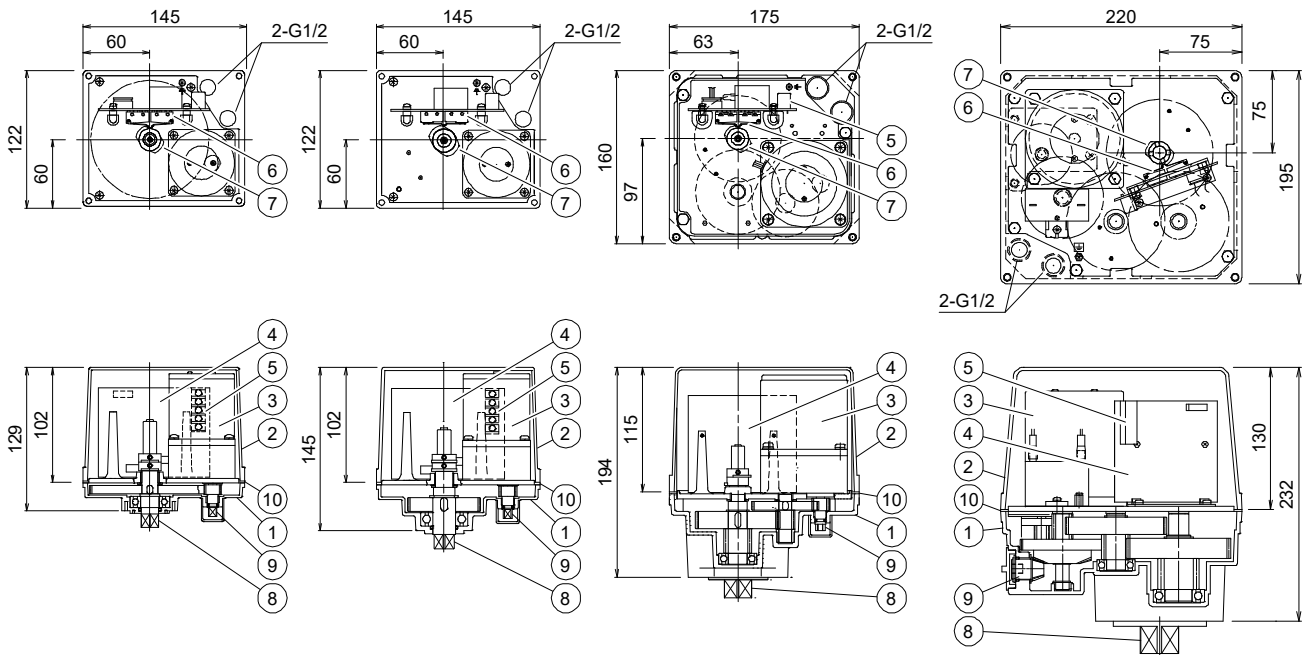

Parts name

1	Body	5	Terminal block	9	Manual shaft
2	Motor cover	6	Limit switch	10	Rubber packing
3	Motor	7	SW setting cam		
4	Control board	8	Drive shaft		

INSTALLATION, OPERATION & MAINTENANCE INSTRUCTIONS

HANDLING & STORAGE

①HANDLING

Do not drop or throw the product as it may break.

②STORAGE

- Store away from dust, moisture and direct sunlight. If possible, store in the original package.
- Do not remove a dust proof cap until the piping.

③CHECKING

- Check the product code, power supply, and voltage before installation.
- Make sure that the bolts are not loose.

INSTALLATION

①PRECAUTIONS

- Flush the pipeline carefully before installing the valve. Foreign particles, such as sand or pieces of welding electrode, will damage the disk and seats.
- Seat has ribs for tight gasket seating. Do not use gasket.
- Valve is shipped closed. (allows quick piping.)
- Disc interference may also occur when valve is installed in pipeline with smaller than normal inside diameter such as thick wall pipe, or lining pipe. Suitable corrective measurement must be taken (taper boring the pipe or pipe liner, etc.)
- When you use a vinyl chloride flange, there is a caliber to be internal off the corners. Please cut off the corners with reference to the following. (F, FN)

Valve size [mm]		Chamfer [mm]
FN	F	
150	150	1.5
-	200	2.5
-	250	3
-	300	2

- Avoid oil or grease when using EPDM seat.

②PIPING FLANGES (F, FN, FE, FZ)

- Class JIS 5K and JIS 10K pipe flanges can be used for FN series. See the drawing below for centering the valve with bolts.

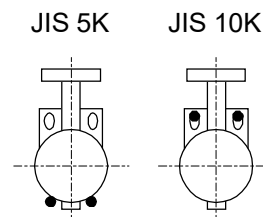

- FZ type has T bar on bolt guide hole.

Flanged-part

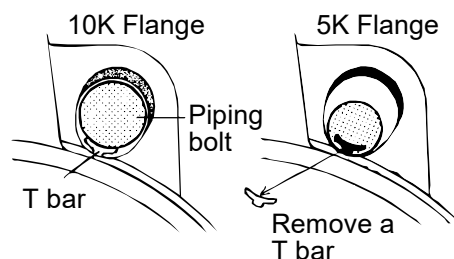

The form of flanged-part is different depending on the size.

- Wafer type butterfly valve is put between two seats of flanged-end and tightened with long bolts.
- Before bolts are tightened, valve should be centered within the bolts to prevent possible disc interference or damage by contact with the pipe or flange.
- Tighten all bolts using crossover method to load the joint evenly.
- When using a resin flange, if the connecting bolt is tightened too much, the flange may deform and leak.

Valve size [mm]				Recommended torque [N·m]
F	FN	FE	FZ	
050	050	040		20
065	065	050		
080	080	065		
100	100	080	100	
125	125	125		25
150	150	150		
200	200	200		
250		250		30
300	-	300		

INSTALLATION, OPERATION & MAINTENANCE INSTRUCTIONS**③CAUTION ON PLASTIC VALVE (FP)**

Flange connection

- Use same material as same as opposite piping flanged. For metal piping, use flanged washer and it is considered that there is no heavy piping stress.
- When the piping, wick gap between a pipe and a valve and a bending cause by an angle difference, it may cause switching incompatible breakage, and leakage from fluid.
- Shaft, face to face dimension distance and flanged angle unit correctly.
- Use the flanged bolt on by bolt side and nut side, tighten all bolts using crossover method to load the joint evenly.

Valve size [mm]	Recommended torques [N·m]
040 050 065 080	20
100 125 150	25
200 250 300	60

⑥OTHER NOTES

Until the wiring is completed there must be no condensation or flooding in the interior of the actuator, after piping. Protective caps on the cable gland are not waterproof.

Expansion measure of pipe line

- Heat expansion occurs in pipe line depends on by temperature change after piping and temperature condition of internal fluid. Compression or contraction by heat stress acts also on a valve. Especially for metal piping, it happens to plastic valve as weak in intensity. Perform expansion treatment before or after a valve and it is considered that a burden is not placed on valve.

④ENVIRONMENT

- Do not install in place where corrosive gas is present or where vibration is heavy (0.5 G or more).
- When radiant heat causes the surface temperature of the control unit to exceed 55 °C, provide an appropriate shielding plate.
- If there is a possibility that the fluid and drive part freeze, please take measures to prevent freezing.

⑤POSITIONING

Should be positioned through 90° upward from horizontal. Provide space around the product to allow manual operation, inspection and replacement work.

Maintenance space for upper part of actuator.

AE (120 / 300 / 600)	More than 105 mm
AE (02K / 06K) AD HD	More than 120 mm

INSTALLATION, OPERATION & MAINTENANCE INSTRUCTIONS**WIRING****①PRECAUTIONS**

- Remove the actuator cover before wiring.
- Two G1/2 electrical connections are provided with a cable gland and plug. Usable cable size is $\Phi 6$ to 12 mm.
- When using a flexible tube, dew condensation may occur inside the actuator due to respiration from the inside of the tube and malfunction may result. Seal the flexible tube connector part with a sealant.
- Sealants that affect the electrical contacts should not be used inside the electric actuator.
- If long distance wiring or low voltage operation, check that terminal voltage is in the proper range.

②CONNECTION

- Do not wiring outdoors on a rainy day.
- Check the power supply and voltage. Connect the signal as shown in the wiring diagram. Do not connect unnecessarily terminal.
- Actuator should be electrically grounded. Use the terminal marked (\oplus) inside the actuator.

PREVENT DEW CONDENSATION

- When installing the cover after wiring, perform the bolt by the temporary tightening procedure and the permanent tightening procedure to tightly and securely tighten the rubber packing so that water does not enter from the outside.
- Tighten the cable gland nut so that there is no leakage from the wire entrance.

CONTROL**①AE1**

Each control switch should be prepared one by one. Do not operate two or more from one switch at the same time.

②AD2, HD2, AE2

When using control switch with current leakage (more than 1 mA) such as TRIAC or relay with CR, it can cause malfunction.

③DC POWER SUPPLY

- Battery or full wave rectification can be used.
 - Consider an inrush current of motor. (It is 1.5 to 3 times of consumed current.)
 - When using a DC voltage, be selected the wire thickness by the wiring distance.
 - Do not use power supply that require more than 1 second with rise and fall time.
- ④USE OF OPEN/SHUT SIGNALS**
Use signals within the capacity of output signal rating.

OPERATION**①TESTING**

- Make sure that power supply voltage is correct. Also check operating position, wiring, speed and signals.
- During trial operation, check that valve movement and OPEN and SHUT signals are correct.

②DUTY CYCLE

Confirm that the operation frequency is within the specified duty cycle.

Use beyond the load time rate range will affect product life. Also, it may cause burnout.

Duty cycle is a value that regulates the opening / closing frequency of the actuator. The meaning of 20 % 15 minutes for Duty cycle is that 3 minutes (20 % of 15 minutes) operation is possible. The calculated value obtained by dividing 3 minutes by the operation time is the number of times of operation within 15 minutes.

③ATTENTION

- Keep power supplied for built-in space heater to prevent condensation inside actuator.
- Do not touch the moving parts of actuator in operation.
- Do not insert a reverse signal during operation. It may shorten the life of product.
- Never put anything on the actuator or make it into a foothold.

INSTALLATION, OPERATION & MAINTENANCE INSTRUCTIONS**MANUAL OPERATION****①PRECAUTIONS**

- Be sure to turn off the power before manual operation.
- Operate manually with reference to the opening degree label. Do not turn beyond the fully open / fully closed position. Operation failure may occur during automatic operation.

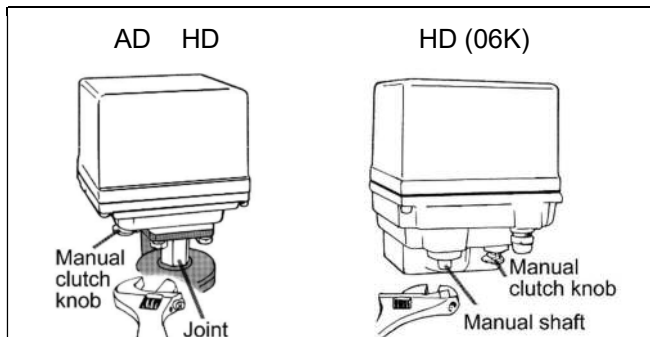
②THE WAY OF OPERATION

Manual operation can be possible by pulling down manual clutch knob. Set the knob to manual position and operate the joint by using an adjustable wrench in the SHUT/OPEN direction. When it becomes in the position besides the range of operation in the case of manual operation, it may stopped automatic moving. In case the manual clutch knob is not easy to pull down, try moving joint or manual shaft to the opposite direction by wrench. For automatic operation, reset the knob to automatic position. Be sure to confirm that knob is reset completely.

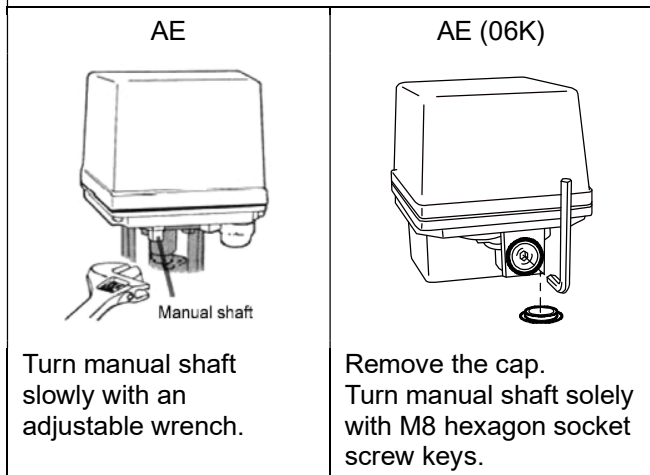

Turn manual shaft slowly with an adjustable wrench.

Remove the cap. Turn manual shaft solely with M8 hexagon socket screw keys.

Before automatic operation, be sure to remove wrench.

MAINTENANCE

- To prevent electric shock, be sure to turn off the power when removing the actuator cover.
- Do the routine maintenance at least once in half a year.

Inspection items

- Confirm operation of opening and closing.
- Confirm that an actuator is not hot excessively.
- Confirm existence of abnormal noise and vibration during operation.
- Confirm whether screws are loose or not.
- Confirm that water or condensation no remains in the actuator.
- Confirm the fluid temperature or pressure.
- Confirm the leak from valve stem.
- Confirm the bolt tightening torque.

INSTALLATION, OPERATION & MAINTENANCE INSTRUCTIONS

TROUBLE SHOOTING

Problem	Cause	Solution
Actuator does not move.	Faulty wiring.	Correct the wiring.
	No voltage is coming.	Check the voltage.
	Incorrect voltage.	When it's burned out by excess voltage, replace the actuator.
	Short the circuit, contact failure.	Review wires and connection.
	Motor is too old.	Replace the actuator. Repair in our factory.
Operation is unstable.	Excess surge or voltage was applied.	<ul style="list-style-type: none"> Replace the control board or limit switch. (Repair in our factory) Replace the actuator.
	Rainwater entered the actuator.	<ul style="list-style-type: none"> Dry the inside. Replace the actuator.
	Added high harmonics noise from an inverter.	Attachment a filter for each inverter maker option.
	Effect of high level noise.	Use the shielded wire and ground the wiring. Separate signal wire from power line.
	Two or more valves operated by the same switch.	Each control switch should be prepared one by one.
	Switch leakage current is large.	Current leakage should be less than 1 mA.

Problem	Cause	Solution
Stop in the mid position.	There is a foreign object in the butterfly valve.	Remove a foreign object.
	Valve is distorted.	Replace the valve.
	Overload protector runs because of over-torque.	Turn off the power for about 3 minutes to remove a heat from motor protection circuit. AD1 HD1 AE1 Motor protection circuit returns by the signal of operation of an opposite direction. Turn on the power again. AD2 HD2 AE2 AD0 HD0
Received the alarm signal.	AD2 HD2 AE2	
Stop automatic moving after manual operation.	Manual clutch knob is not reset.	Reset manual clutch knob.
	Out of operating range. (06K)	Reset by manual operation.
Leakage from valve stem	Stem packing is worn.	Replace the valve.
		Replace the O-ring. F
Leakage from valve seat	Damaged on valve seat.	Replace the valve.
		Replace the seat. F

For more information contact
NIPPON VALVE CONTROLS, INC. for consultation.