

Size (mm)	d	L	D	C	n-h	H	Weight (kg)	Cv ON-OFF	Actuator			Sizing code
20	20	150	100	75	4-15	277	9.7	24	HD1-300	HD2-300	HD0-300	0
25	25	170	125	90	4-19	284	12	40	HD1-300	HD2-300	HD0-300	0
40	40	200	140	105	4-19	299	15	100	HD1-300	HD2-300	HD0-300	0
						299	15		HD1-700	HD2-700	HD0-700	2
50	50	230	155	120	4-19	307	18	170	HD1-700	HD2-700	HD0-700	0
65	65	260	175	140	4-19	330	24	240	HD1-700	HD2-700	HD0-700	0
80	80	280	185	150	8-19	342	27	380	HD1-700	HD2-700	HD0-700	0
						364	29		HD1-02K	HD2-02K	HD0-02K	2
100	100	340	210	175	8-19	390	39	680	HD1-02K	HD2-02K	HD0-02K	0

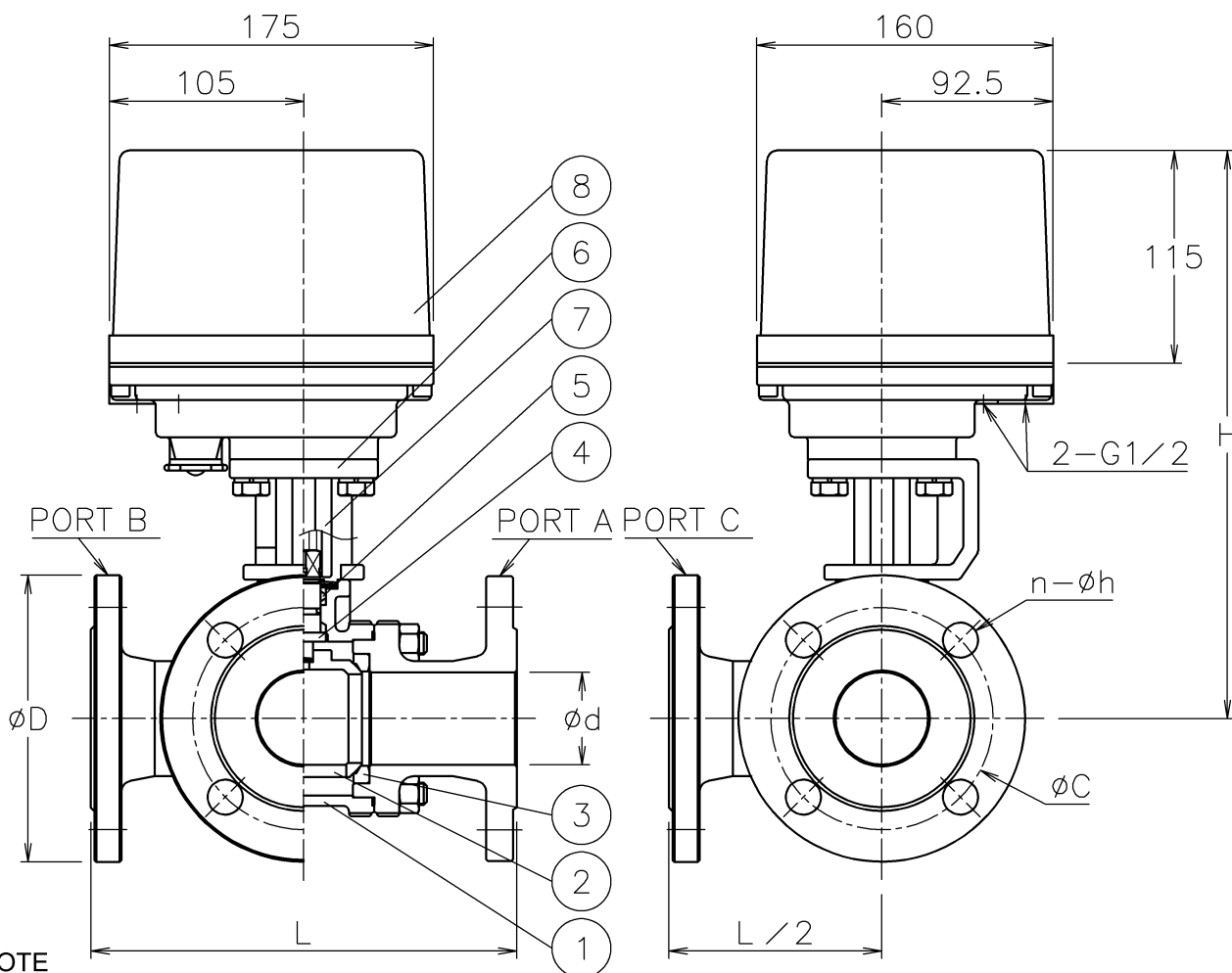

**NOTE**

**Attachment**

- Cable gland (nylon), G1/2, for  $\phi 6 \sim 12$  cable
- Plug

**Flow paths (Top view of valve)**

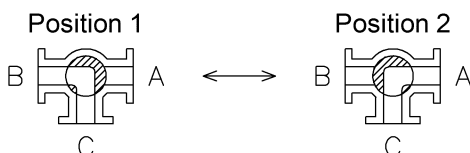

8	Actuator	Aluminum alloy die-cast cover	1	
7	Joint	SCS13A	1	
6	Bracket	SCS13A	1	
5	Packing	R-PTFE	1set	
4	Stem	SUS304	1	
3	Seat	R-PTFE	2	
2	Ball	SUS304/SCS13A	1	
1	Body	SCS13A	1	
No	DESCRIPTION	MATERIALS	REQ'D	REMARKS

			APPR'D	H.F	TITLE	J10K Flanged-end LR type electric actuated 3 way ball valve					
			CHK'D	K.Y		MODEL	HD1LR**1TTP HD0LR0*1TTP HD2LR**1TTP				
			DESIGN		SCALE		NON	DWG No.	LR-*1TTP-HD2-EN		
MARK	DATE	BY	DATE	'17-03-24							
REVISIONS				<b>NIPPON VALVE CONTROLS, INC.</b>							
MV-2602											