

Size (mm)	d	L	L1	J10K		J20K		W	H	Weight (kg)	Cv	Actuator
				C	n-h	C	n-h					
15	15	40	25	70	4-15	70	4-15	115	115	1	4	Lever
20	20	50	30	75	4-15	75	4-15	115	117	1.2	8	Lever
25	25	60	30	90	4-19	90	4-19	145	136	1.8	9	Lever
32	32	70	35	100	4-19	100	4-19	145	139	2.3	22	Lever

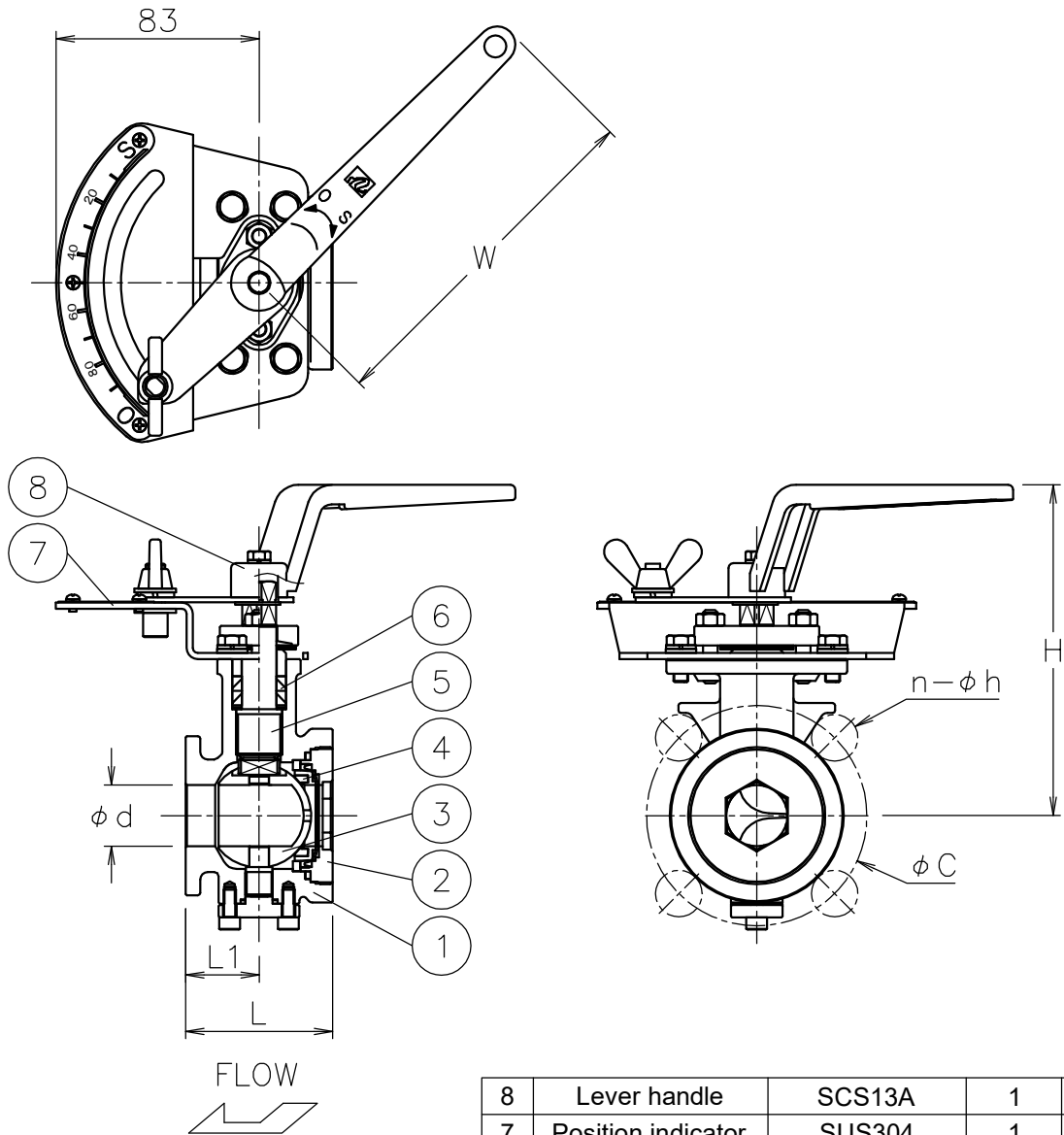

NOTE
(a) Lever handle is removed and shipped.

8	Lever handle	SCS13A	1	(a)
7	Position indicator	SUS304	1	
6	Packing	R-PTFE	2	
5	Stem	SUS316	1	
4	Seat	R-PTFE	1	
3	Ball	SCS14A	1	HCr PLTD
2	Cap	SCS14A	1	
1	Body	SCS14A	1	
No	DESCRIPTION	MATERIALS	REQ'D	REMARKS

			APPR'D	H.F	TITLE	J10K/20K Flanged-end (Wafer type) GS type ball valve								
			CHK'D	K.Y										
			DESIGN							MODEL	MA-GSL-3UUGV			
			DRAWN	S.O										
MARK	DATE	BY	DATE	'16-11-04	SCALE	NON	DWG No.	GS-3UUG-V-L-MA4-EN						
REVISIONS														
MV-2563														