

Size [mm]	d	L	L1	J10K		J20K		W1	W2	W3	W4	W5	H	Weight [kg]	Cv	Actuator	Sizing code
				C	n-h	C	n-h										
40	32	80	37	105	4-19	105	4-19	122	60	145	60	102	245	5.2	95	AE*-360	2
50	38	95	45	120	4-19	120	8-19	122	60	145	60	102	292	6.8	135	AE*-700	2
65	50	110	50	140	4-19	140	8-19	122	60	145	60	102	300	8.5	195	AE*-700	2
80	64	125	57	150	8-19	160	8-23	160	97	175	63	115	397	18	410	AE*-02K	2
100	74	145	67	175	8-19	185	8-23	160	97	175	63	115	422	23	430	AE*-02K	2
125	100	176	81	210	8-23	225	8-25	195	75	220	75	130	499	38	900	AE*-06K	2

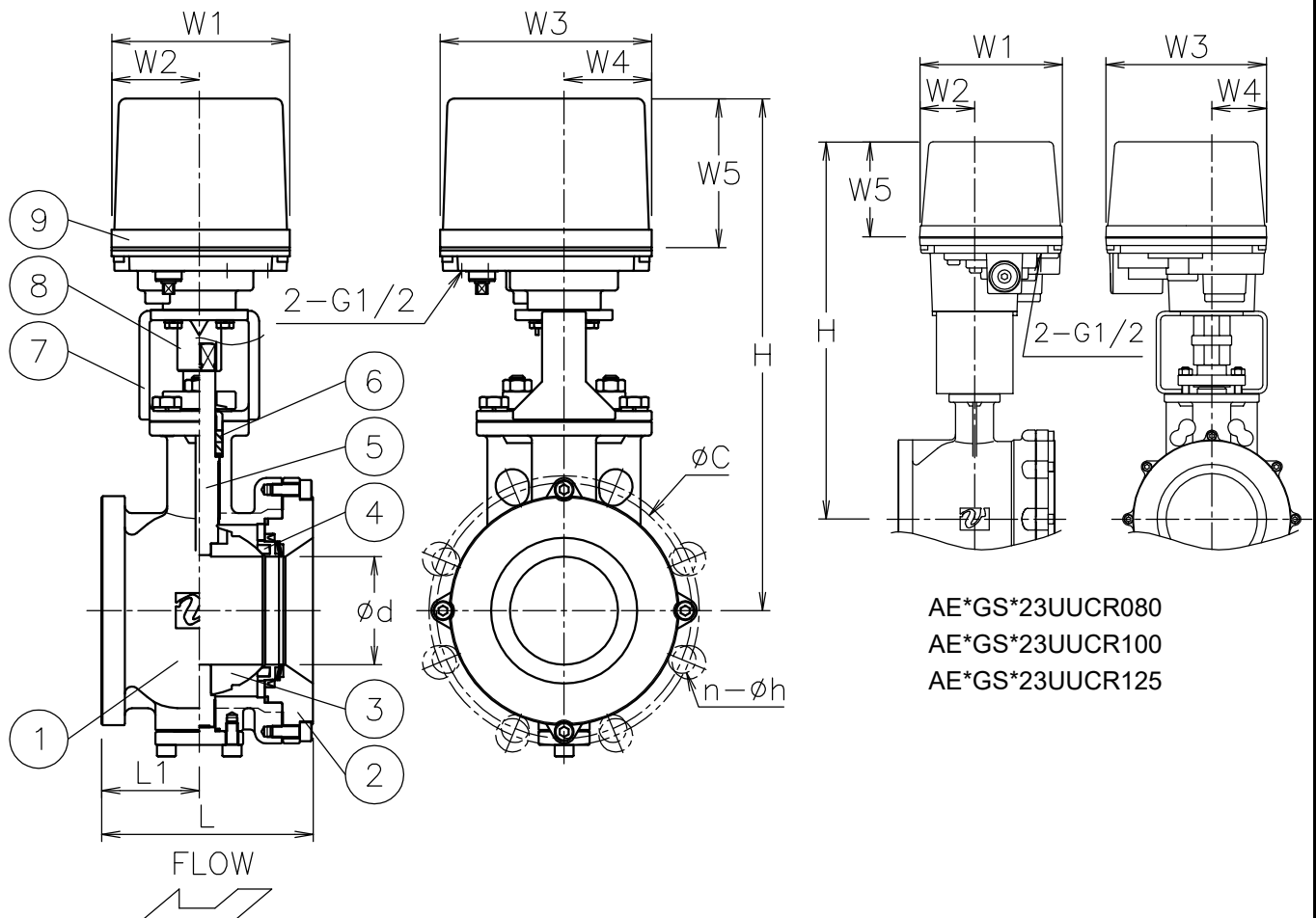

NOTE

Actuator material: Aluminum alloy diecast cover.

ATTACHMENT

Cable gland (nylon), G1/2, for 6φ to 12φ cable.
Plug.

9	Actuator		1	
8	Joint	SUS304/SCS13A	1	
7	Bracket	SUS304/SCS13A	1	
6	Packing	R-PTFE	2	
5	Stem	SUS316	1	
4	Seat	R-PEEK	1	
3	Ball	SCS14A	1	HCr PLTD
2	Cap	SCS14A	1	
1	Body	SCS14A	1	
No	DESCRIPTION	MATERIALS	REQ'D	REMARKS

			APPR'D	H.F	TITLE	J10K/20K Flanged-end (Wafer type) GS type electric actuated ball valve			
			CHK'D	K.Y					
			DESIGN		MODEL	AE1GS*23UUCR AE2GS*23UUCR			
			DRAWN	S.O					
MARK	DATE	BY	DATE	'17-03-16	SCALE	NON	DWG No.	GS-23UUC-R-AE3-EN	
REVISIONS			 NIPPON VALVE CONTROLS, INC.						
MV-2598									